

**MODULE - 1**  
**INTEGRAL CALCULUS**

**Multiple Integral**

**DOUBLE INTERGALS**

Consider a function  $f(x, y)$  of the independent variables  $x, y$  defined at each point I the finite region  $R$  of the  $xy$ -plane. Divide  $R$  into  $n$  elementary areas  $\delta A_1, \delta A_2, \dots, \delta A_n$ . Let  $(x_r, y_r)$  be any point within the  $r^{\text{th}}$  elementary area  $\delta A_r$ . Then consider the sum  $\sum_{r=1}^n f(x_r, y_r) \delta A_r$

i.e.  $f(x_1, y_1) \delta A_1 + f(x_2, y_2) \delta A_2 + \dots + f(x_n, y_n) \delta A_n$

The limit of this sum, if it exists, as  $n \rightarrow \infty$  is defined as the double integral of  $f(x, y)$  over the region  $R$  and is written as  $\iint_R f(x, y) dA$  Thus  $\iint_R f(x, y) dA = \lim_{\substack{n \rightarrow \infty \\ \delta A \rightarrow 0}} \sum_{r=1}^n f(x_r, y_r) \delta A_r$

**Evaluation of double:**

(i) If  $R$  is a region in the  $xy$ -plane bounded by the curves  $y = y_1(x), y = y_2(x)$  and the lines  $x = a, x = b$ , then we have

$$\iint_R f(x, y) dA = \int_a^b \left( \int_{y_1(x)}^{y_2(x)} f(x, y) dy \right) dx$$

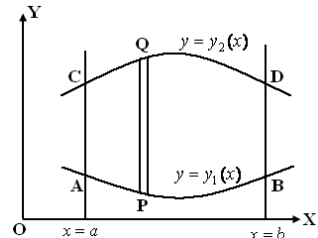

(ii) If  $R$  is a region in the  $xy$ -plane bounded by the curves  $x = x_1(y), x = x_2(y)$  and the lines  $y = c, y = d$ , then we have

$$\iint_R f(x, y) dA = \int_c^d \left( \int_{x_1(y)}^{x_2(y)} f(x, y) dx \right) dy$$

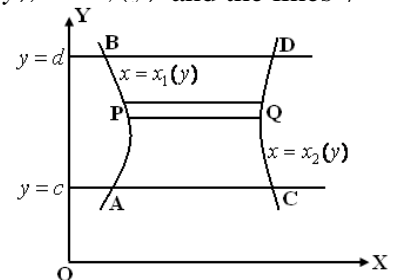

(iii) If  $R$  is a rectangular region bounded by the lines  $x = a, x = b, y = c, y = d$  then we have

$$\iint_R f(x, y) dA = \int_c^d \int_a^b f(x, y) dx dy = \int_a^b \int_c^d f(x, y) dy dx$$

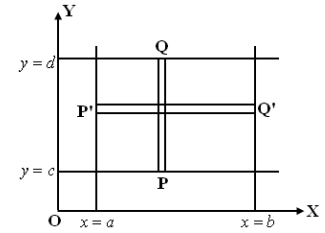

**Double integrals:**  $\iint f(x, y) dA = \int_{x_1}^{x_2} \int_{y_1}^{y_2} f(x, y) dy dx$

**Evaluate the following:**

1.  $\int_0^1 \int_x^{\sqrt{x}} xy \, dy dx$

**Sol:** 
$$I = \int_0^1 x \left[ \frac{y^2}{2} \right]_x^{\sqrt{x}} dx$$

$$= \frac{1}{2} \int_0^1 x [x - x^2] dx$$

$$= \frac{1}{2} \int_0^1 [x^2 - x^3] dx$$

$$= \frac{1}{2} \left[ \frac{x^3}{3} - \frac{x^4}{4} \right]_0^1$$

$$I = \frac{1}{24}$$

2.  $\int_0^1 \int_0^y xy(x+y) dy dx$

**Sol:** 
$$I = \int_0^1 \int_0^y (x^2y + y^2x) dy dx$$

$$= \int_0^1 \left[ y \frac{x^3}{3} + y^2 \frac{x^2}{2} \right]_0^y dy$$

$$= \int_0^1 \left[ \frac{y^4}{3} + \frac{y^4}{2} \right] dy$$

$$= \int_0^1 \frac{5y^4}{6} dy$$

$$= \frac{5}{6} \left[ \frac{y^5}{5} \right]_0^1$$

$$I = \frac{1}{6}$$

$$3 \int_0^1 \int_0^{x^2} e^{\frac{y}{x}} dy dx$$

$$\begin{aligned} \text{Sol: } I &= \int_{x=0}^1 \int_{y=0}^{x^2} e^{\frac{y}{x}} dy dx \\ &= \int_{x=0}^1 \left[ \frac{e^{\frac{y}{x}}}{\frac{1}{x}} \right]_0^{x^2} dx \\ &= \int_{x=0}^1 x [e^{x^2/x} - e^0] dx \\ &= \int_{x=0}^1 x [e^x - 1] dx \\ &= \int_{x=0}^1 [xe^x - x] dx \\ &= \left[ xe^x - e^x - \frac{x^2}{2} \right]_0^1 \end{aligned}$$

$$I = \frac{1}{2}$$

$$4. \int_0^1 \int_0^1 \frac{1}{\sqrt{1-x^2}} \frac{1}{\sqrt{1-y^2}} dy dx$$

$$\begin{aligned} \text{Sol: Let } I &= \int_0^1 \int_0^1 \frac{1}{\sqrt{1-x^2}} \frac{1}{\sqrt{1-y^2}} dy dx \\ &= \int_0^1 \frac{1}{\sqrt{1-x^2}} dx \int_0^1 \frac{1}{\sqrt{1-y^2}} dy \\ &= [\sin^{-1}x]_0^1 [\sin^{-1}y]_0^1 \\ &= (\sin^{-1}1 - \sin^{-1}0)(\sin^{-1}1 - \sin^{-1}0) \\ &= \left(\frac{\pi}{2} - 0\right) \left(\frac{\pi}{2} - 0\right) \end{aligned}$$

$$I = \frac{\pi^2}{4}$$

$$5. \int_0^1 \int_0^{\sqrt{1+x^2}} \frac{1}{1+x^2+y^2} dy dx$$

$$\text{Sol: } I = \int_0^1 \int_0^{\sqrt{1+x^2}} \frac{1}{1+x^2+y^2} dy dx$$

$$\text{Let } 1+x^2 = a^2 \text{ or } a = \sqrt{1+x^2}$$

$$\begin{aligned} I &= \int_0^1 \int_0^a \frac{dy}{a^2+y^2} dx \\ &= \int_0^1 \frac{1}{a} \left[ \tan^{-1} \left( \frac{y}{a} \right) \right]_0^a dx \end{aligned}$$

$$\begin{aligned}
&= \int_0^1 \frac{1}{a} [\tan^{-1}(1) - \tan^{-1}(0)] dx \\
&= \frac{1}{a} \int_0^1 \frac{\pi}{4} dx \quad \text{Since } a = \sqrt{1+x^2} \\
&= \frac{\pi}{4} \int_0^1 \frac{1}{\sqrt{1+x^2}} dx \\
&= \frac{\pi}{4} [\log(x + \sqrt{1+x^2})]_0^1 \\
&= \frac{\pi}{4} [\log(1 + \sqrt{2}) - \log 1] \\
\mathbf{I} &= \frac{\pi}{4} \log(1 + \sqrt{2})
\end{aligned}$$

**Triple integrals:**

$$\iint f(x, y, z) dA = \int_{x_1}^{x_2} \int_{y_1}^{y_2} \int_{z_1}^{z_2} f(x, y, z) dz dy dx$$

**Evaluate the following:**

1.  $\int_0^1 \int_0^x \int_0^{xz} xyz \, dz dy dx$

**Sol:** Let  $I = \int_0^1 \int_0^x \int_0^{xz} xyz \, dz dy dx$

$$= \int_0^1 \int_0^x xz \left[ \frac{y^2}{2} \right]_0^{xz} dz dx$$

$$= \frac{1}{2} \int_0^1 \int_0^x xz (x^2 z^2 - 0) dz dx$$

$$I = \frac{1}{2} \int_0^1 \int_0^x x^3 z^3 dz dx$$

$$= \frac{1}{2} \int_0^1 x^3 \left[ \frac{z^4}{4} \right]_0^x dx$$

$$= \frac{1}{8} \int_0^1 x^3 (x^4 - 0) dx$$

$$= \frac{1}{8} \int_0^1 x^7 dx = \frac{1}{8} \left[ \frac{x^8}{8} \right]_0^1 = \frac{1}{64}$$

$\therefore I = \frac{1}{64}$

2.  $\int_{-c}^c \int_{-b}^b \int_{-a}^a (x^2 + y^2 + z^2) dz dy dx$

**Sol:**

$$\text{Let } I = \int_{-c}^c \int_{-b}^b \int_{-a}^a (x^2 + y^2 + z^2) dz dy dx$$

$$= \int_{-c}^c \int_{-b}^b \left( x^2 z + y^2 z + \frac{z^3}{3} \right)_{-a}^a dy dx$$

$$= \int_{-c}^c \int_{-b}^b \left( 2ax^2 + 2ay^2 + \frac{2a^3}{3} \right) dy dx$$

$$= \int_{-c}^c \left( 2ax^2 y + 2a \frac{y^3}{3} + \frac{2a^3}{3} y \right)_{-b}^b dx$$

$$= \int_{-c}^c \left( 4abx^2 + \frac{4ab^3}{3} + \frac{4a^3b}{3} \right) dx$$

$$= \left[ 4ab \frac{x^3}{3} + \frac{4ab^3}{3} x + \frac{4a^3b}{3} x \right]_{-c}^c$$

$$\therefore I = \frac{8}{3} abc(a^2 + b^2 + c^2)$$

$$3. \int_{-1}^1 \int_0^z \int_{x-z}^{x+z} (x + y + z) dz dy dx$$

$$\text{Sol: Let } I = \int_{-1}^1 \int_0^z \int_{x-z}^{x+z} (x + y + z) dz dy dx$$

$$= \int_{-1}^1 \int_0^z \left( xy + \frac{y^2}{2} + zy \right)_{x-z}^{x+z} dx dz$$

$$= \int_{-1}^1 \int_0^z (4xz + 2z^2) dx dz$$

$$= \int_{-1}^1 \left[ 4 \frac{x^2}{2} z + 2z^2 x \right]_0^z dz$$

$$= \int_{-1}^1 [2z(z^2 - 0) + 2z^2(z - 0)] dz$$

$$= \int_{-1}^1 4z^3 dz$$

$$\therefore I = \left[ 4 \frac{z^4}{4} \right]_{-1}^{-1} = 0$$

$$4. \int_0^1 \int_0^{\sqrt{1-x^2}} \int_0^{\sqrt{1-x^2-y^2}} xyz dz dy dx$$

$$\begin{aligned}
\text{Sol: Let } I &= \int_0^1 \int_0^{\sqrt{1-x^2}} \int_0^{\sqrt{1-x^2-y^2}} xyz \, dz dy dx \\
&= \int_0^1 \int_0^{\sqrt{1-x^2}} xy \left[ \frac{z^2}{2} \right]_0^{\sqrt{1-x^2-y^2}} dy dx \\
&= \int_0^1 \int_0^{\sqrt{1-x^2}} (xy - x^3y - xy^3) dy dx \\
&= \int_0^1 \left[ x \frac{y^2}{2} - x^3 \frac{y^2}{2} - x \frac{y^4}{4} \right]_0^{\sqrt{1-x^2}} dx \\
&= \frac{1}{8} \int_0^1 (x - 2x^3 + x^5) dx \\
&= \frac{1}{8} \left[ \frac{x^2}{2} - \frac{2x^4}{4} + \frac{x^6}{6} \right]_0^1 \\
\therefore I &= \frac{1}{48}
\end{aligned}$$

$$5. \int_0^1 \int_0^{\sqrt{a^2-x^2}} \int_0^{\sqrt{a^2-x^2-y^2}} xyz \, dz dy dx$$

$$\therefore I = \frac{a^6}{48}$$

## Evaluation of double integrals- change of order of integration.

### 1. Straight lines.

- $X=0$  is an equation of y-axis.
- $Y=0$  is an equation of x-axis.
- $X=h$  is an equation of line parallel to y-axis.
- $Y=k$  is an equation of line parallel to x-axis.
- $Y=m x$  is an equation of line passing through origin.
- $Y=x$  is an equation of line passing through origin making an angle 45 degree with x-axis
- $\frac{x}{a} + \frac{y}{b} = 1$

is the equation of line passing through the points  $(a, 0)$  and  $(0, b)$ .

$$\bullet (x - x_1)(x - x_2) = (y - y_1)(y - y_2)$$

is the equation of the line passing through the given two points.

### 2. Circles.

- $x^2 + y^2 = a^2$

is an equation of the circle with the center at origin and radius a

- $(x - h)^2 + (y - k)^2 = r^2$

is an equation of circle with centre at (h,k) and radius r.

**3. Ellipse** :  $\frac{x^2}{a^2} + \frac{y^2}{b^2} = 1$

**4. Parabola.**

- $y^2 = 4ax$  is symmetric about positive x – axis.
- $x^2 = 4ay$  is symmetric about positive y – axis
- $y^2 = -4ax$  is symmetric about negative x – axis.
- $x^2 = -4ay$  is symmetric about negative y – axis

**Problems**

**Evaluate the following by changing the order of the integration**

1. Evaluate  $\int_0^1 \int_x^{\sqrt{x}} xy \, dy \, dx$  by changing the order of the integration.

Sol: Let  $I = \int_0^1 \int_x^{\sqrt{x}} xy \, dy \, dx$

Given Limits  $x : x = 0$  to  $x = 1$

$y : y = x$  to  $y = \sqrt{x}$  or  $y^2 = x$

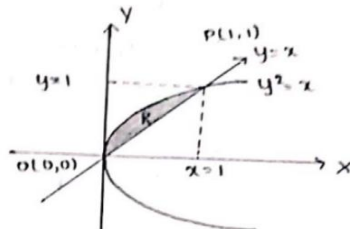

On changing the order of the integration.

$$x : x = y^2 \text{ to } x = y$$

$$y : y = 0 \text{ to } y = 1$$

$$\therefore I = \int_{y=0}^1 \int_{x=y^2}^y y (x dx) dy$$

$$= \int_{y=0}^1 y \left[ \frac{x^2}{2} \right]_{y^2}^y dy$$

$$= \frac{1}{2} \int_{y=0}^1 y(y^2 - y^4) dy$$

$$= \frac{1}{2} \int_{y=0}^1 (y^3 - y^5) dy$$

$$= \frac{1}{2} \left[ \frac{y^4}{4} - \frac{y^6}{6} \right]_0^1$$

$$\therefore I = \frac{1}{24}$$

2. Evaluate  $\iint xy(x+y) dy dx$  taken over the area between

$$y = x^2 \text{ to } y = x$$

**Sol:**  $y = x^2 \text{ to } y = x \Rightarrow x^2 = x \text{ or } x^2 - x = 0$

$$\Rightarrow x(x-1) = 0 \therefore x = 0, 1$$

This gives  $y = 0, y = 1$  and hence the two curves intersect at the points  $(0,0)$  and  $(1,1)$

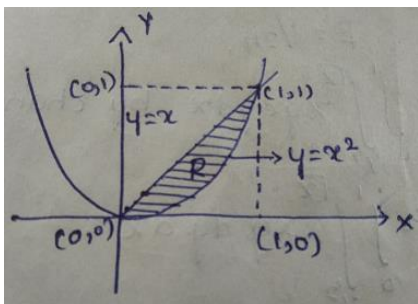

$$\therefore \iint xy(x+y) dy dx = \int_{x=0}^1 \int_{y=x^2}^x (x^2y + xy^2) dy dx$$

$$\begin{aligned}
&= \int_{x=0}^1 \left[ x^2 \frac{y^2}{2} + x \frac{y^3}{3} \right]_{x^2}^x dx \\
I &= \int_{x=0}^1 \left( \frac{x^4}{2} + \frac{x^4}{3} - \frac{x^6}{2} - \frac{x^7}{3} \right) dx \\
&= \left( \frac{x^5}{10} + \frac{x^5}{15} - \frac{x^7}{14} - \frac{x^8}{24} \right)_{x=0}^1 \\
\therefore I &= \frac{3}{56}
\end{aligned}$$

3. Change the order of the integration and hence evaluate

$$\int_0^{4a} \int_{\frac{x^2}{4a}}^{2\sqrt{ax}} xy \, dy \, dx$$

**Sol:** We have  $I = \int_{x=0}^{4a} \int_{y=\frac{x^2}{4a}}^{2\sqrt{ax}} xy \, dy \, dx$

We have  $\frac{x^2}{4a} = 2\sqrt{ax} \Rightarrow x^4 = 64a^3x \Rightarrow x = 0$  and  $x = 4a$

from  $y = \frac{x^2}{4a}$  we get  $y = 0$  and  $y = 4a$

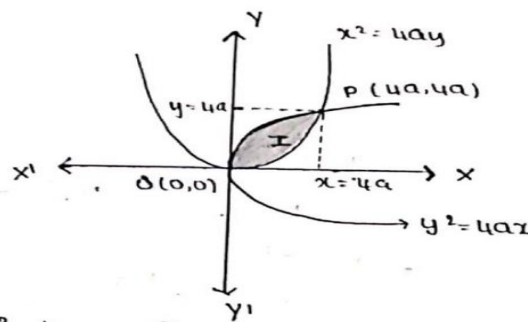

$$\therefore I = \int_{y=0}^{4a} \int_{x=\frac{y^2}{4a}}^{2\sqrt{ay}} y(x \, dx) \, dy$$

$$\begin{aligned}
 I &= \int_{y=0}^{4a} y \left[ \frac{x^2}{2} \right]_{x=\frac{y^2}{4a}}^{2\sqrt{ay}} dy \\
 &= \int_{y=0}^{4a} \left( 2ay^2 - \frac{y^5}{32a^2} \right) dy \\
 &= \left( 2a \frac{y^3}{3} - \frac{1}{32a^2} \frac{y^6}{6} \right) \Big|_0^{4a} \\
 \therefore I &= 64 \frac{a^4}{3}
 \end{aligned}$$

4. Change the order of the integration and hence evaluate

$$\int_0^\infty \int_x^\infty \frac{e^{-y}}{y} dy dx$$

$$\text{Sol : Let } I = \int_{x=0}^\infty \int_{y=x}^\infty \frac{e^{-y}}{y} dy dx$$

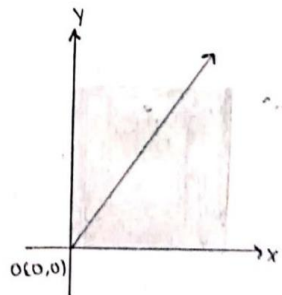

On changing the order of the limit ,  
we must have  $y = 0$  to  $y = \infty$  and  $x = 0$  to  $x = y$

$$\begin{aligned}
 \therefore I &= \int_{y=0}^\infty \int_{x=0}^y \frac{e^{-y}}{y} dx dy = \int_{y=0}^\infty \frac{e^{-y}}{y} [x]_{x=0}^y dy \\
 &= \int_{y=0}^\infty \frac{e^{-y}}{y} y dy = \int_{y=0}^\infty e^{-y} dy \\
 &= \left[ \frac{e^{-y}}{-1} \right]_0^\infty = -(0 - 1) = 1 \\
 \therefore I &= 1
 \end{aligned}$$

5. Evaluate  $\int_0^a \int_y^a \frac{x}{x^2+y^2} dy dx$  by changing the order of the integration.

*Sol:* Let  $I = \int_0^a \int_y^a \frac{x}{x^2+y^2} dy dx$

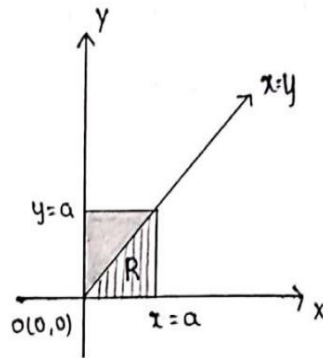

The region bounded by the curve  $x = y$ ,  $x = a$  embedded between the lines  $y = 0$  and  $y = a$  is as shown in figure.

$$\begin{aligned}
 I &= \int_{x=0}^a \int_{y=0}^x x \left( \frac{1}{x^2+y^2} dy \right) dx \\
 &= \int_{x=0}^a x \frac{1}{x} \left[ \tan^{-1} y/x \right]_{y=0}^x dx = \int_{x=0}^a [ \tan^{-1}(1) - 0 ] dx \\
 &= \int_{x=0}^a \frac{\pi}{4} dx = \frac{\pi}{4} \int_{x=0}^a 1. dx \\
 &= \frac{\pi}{4} [x]_0^a = \frac{\pi}{4} a \\
 \therefore I &= \frac{\pi a}{4}
 \end{aligned}$$

**Evaluation by changing into Polar coordinates**

1. Evaluate  $\int_0^\infty \int_0^\infty e^{-(x^2+y^2)} dy dx$  by changing to polar coordinates

**Sol:** In polar we have  $x = r \cos \theta$ ,  $y = r \sin \theta$

$\therefore x^2 + y^2 = r^2$  and  $dx dy = r dr d\theta$

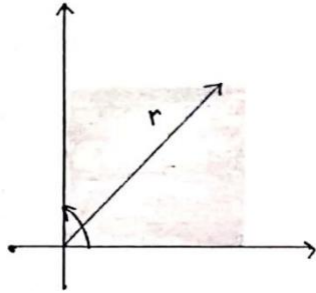

Since  $x$  varies from  $0$  to  $\infty \Rightarrow r$  varies from  $0$  to  $\infty$

In the 1st quadrant  $\theta$  varies from  $0$  to  $\frac{\pi}{2}$

Hence  $\int_{\theta=0}^{\frac{\pi}{2}} \int_{r=0}^{\infty} e^{-r^2} r dr d\theta$

Put  $r^2 = t \Rightarrow 2rdr = dt \Rightarrow rdr = \frac{dt}{2}$

and  $t$  also varies from  $0$  to  $\infty$

$$\begin{aligned} I &= \int_{\theta=0}^{\frac{\pi}{2}} \int_{t=0}^{\infty} e^{-t} \frac{dt}{2} d\theta \\ &= \frac{1}{2} \int_{\theta=0}^{\frac{\pi}{2}} \left[ \frac{e^{-t}}{-1} \right]_{t=0}^{\infty} d\theta \\ &= \frac{1}{2} \int_{\theta=0}^{\frac{\pi}{2}} -(0 - 1) d\theta \\ &= \frac{1}{2} \int_{\theta=0}^{\frac{\pi}{2}} 1 d\theta \\ &= \frac{1}{2} [\theta]_{\theta=0}^{\frac{\pi}{2}} \\ \therefore I &= \frac{\pi}{4} \end{aligned}$$

2. Evaluate  $\int_0^a \int_0^{\sqrt{a^2-y^2}} y\sqrt{x^2+y^2} dx dy$  by changing to polar coordinate

Sol: we have  $x = \sqrt{a^2 - y^2}$  or

$\therefore x^2 + y^2 = a^2$ ; it is circle with radius  $a$

Since  $y$  varies from  $0$  to  $a$  the region of integration is in the 1st quadrant

In the 1st quadrant  $\theta$  varies from  $0$  to  $\frac{\pi}{2}$

In polar we have  $x = r\cos\theta$ ,  $y = r\sin\theta \Rightarrow dxdy = r dr d\theta$

$\therefore x^2 + y^2 = r^2$  i.e.,  $r^2 = a^2 \Rightarrow r = a$

Also  $x = 0$ ,  $y = 0$  will give  $r = 0$  hence  $r$  varies from  $0$  to  $a$

$$\begin{aligned} \therefore I &= \int_{r=0}^a \int_{\theta=0}^{\frac{\pi}{2}} r\sin\theta \cdot r \cdot r dr d\theta \\ &= \int_{r=0}^a \int_{\theta=0}^{\frac{\pi}{2}} r^3 \sin\theta d\theta dr \\ &= \int_{r=0}^a r^3 (-\cos\theta)_{\theta=0}^{\frac{\pi}{2}} dr \end{aligned}$$

$$\begin{aligned}
&= \int_{r=0}^a -r^3 \left( \cos \frac{\pi}{2} - \cos 0 \right) dr \\
&= \int_{r=0}^a r^3 dr \\
&= \left[ \frac{r^4}{4} \right]_0^a \\
\therefore I &= \frac{a^4}{4}
\end{aligned}$$

### Application of Double and Triple internals

1. Area of Region R in the Cartesian form:  $\iint_R dx dy$
2. Area of Region R in the Polar form:  $\iint_R r dr d\theta$
3. Volume of solid in the Cartesian form:  $\iiint_V dx dy dz$
4. Volume of solid in the Polar form:  $\iint_R 2\pi r^2 \sin\theta dr d\theta$

1. Find the area of the ellipse  $\frac{x^2}{a^2} + \frac{y^2}{b^2} = 1$  by double integration.

Sol: Let  $\frac{x^2}{a^2} + \frac{y^2}{b^2} = 1$  is ellipse

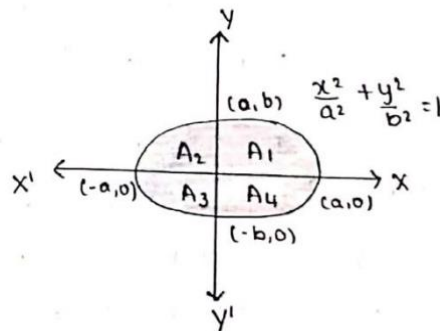

$$\begin{aligned}
\text{Area, } A &= 4 \int_{x=0}^a \int_{y=0}^{\frac{b}{a}\sqrt{a^2-x^2}} dy dx \\
&= 4 \int_{x=0}^a [y]_0^{\frac{b}{a}\sqrt{a^2-x^2}} dx \\
&= 4 \int_{x=0}^a \frac{b}{a} \sqrt{a^2-x^2} dx \\
&= \frac{4b}{a} \int_{x=0}^a \sqrt{a^2-x^2} dx \\
&= \frac{4b}{a} \left[ \frac{x}{2} \sqrt{a^2-x^2} + \frac{a^2}{2} \sin^{-1} \left( \frac{x}{a} \right) \right]_0^a \\
&= \frac{4b}{a} \left[ \frac{a^2}{2} \sin^{-1}(1) \right]
\end{aligned}$$

$$= \frac{4b}{a} \left[ \frac{a^2 \pi}{2 \cdot 2} \right]$$

$\therefore A = \pi ab$  sq. units

2. Find by double integration the area lying between the circle

$x^2 + y^2 = a^2$ , line  $x + y = a$  in the 1st quadrant.

$$\text{Sol: } A = \int_{x=0}^a \int_{y=a-x}^{\sqrt{a^2-x^2}} dy dx$$

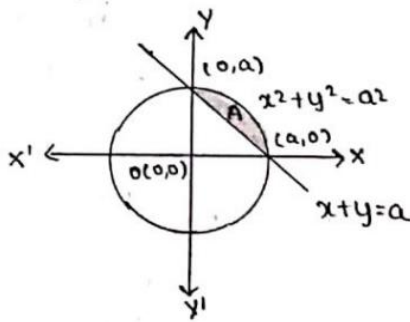

$$\begin{aligned} A &= \int_{x=0}^a [y]_{a-x}^{\sqrt{a^2-x^2}} dx \\ &= \int_{x=0}^a (\sqrt{a^2-x^2} - a + x) dx \\ &= \frac{4b}{a} \int_{x=0}^a \sqrt{a^2-x^2} dx \\ &= \left[ \frac{x}{2} \sqrt{a^2-x^2} + \frac{a^2}{2} \sin^{-1} \left( \frac{x}{a} \right) - ax + \frac{x^2}{2} \right]_0^a \\ &= \left[ \frac{a^2}{2} \sin^{-1}(1) - a^2 + \frac{a^2}{2} \right] \\ &= \frac{a^2 \pi}{2 \cdot 2} - \frac{a^2}{2} \\ &= \frac{a^2}{2} \left( \frac{\pi}{2} - 1 \right) \\ \therefore A &= \frac{a^2(\pi - 2)}{4} \text{ sq. units} \end{aligned}$$

3. Find by double integration the area enclosed by the curve

$r = a(1 + \cos\theta)$  between  $\theta = 0$  to  $\theta = \pi$

$$\text{Sol: } A = \int_{\theta=0}^{\pi} \int_{r=0}^{a(1+\cos\theta)} r \, dr \, d\theta$$

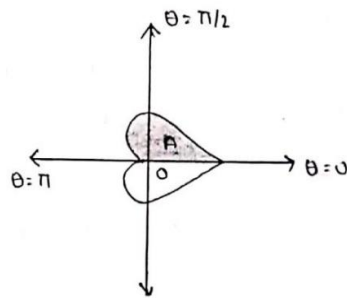

$$\begin{aligned} A &= \int_{\theta=0}^{\pi} \left[ \frac{r^2}{2} \right]_0^{a(1+\cos\theta)} d\theta \\ &= \frac{1}{2} \int_{\theta=0}^{\pi} a^2 (1 + \cos\theta)^2 d\theta \\ &= \frac{1}{2} \int_{\theta=0}^{\pi} a^2 \left( 2\cos^2\left(\frac{\theta}{2}\right) \right)^2 d\theta \\ &= \frac{a^2}{2} \int_{\theta=0}^{\pi} 4\cos^4\left(\frac{\theta}{2}\right) d\theta \\ &= 2a^2 \int_{\theta=0}^{\pi} \cos^4\left(\frac{\theta}{2}\right) d\theta \end{aligned}$$

Put  $\frac{\theta}{2} = t \Rightarrow \theta = 2t \Rightarrow d\theta = 2dt$

if  $\theta$  varies from 0 to  $\pi$  then  $t$  also varies from 0 to  $\frac{\pi}{2}$

$$\begin{aligned} A &= 2a^2 \int_{t=0}^{\frac{\pi}{2}} \cos^4 t \cdot 2 dt \\ &= 4a^2 \left[ \frac{3}{4} \cdot \frac{1}{2} \right] \frac{\pi}{2} \\ \therefore A &= \frac{3a^2\pi}{4} \text{ sq. units} \end{aligned}$$

4. Find the volume generated by the revolution of the cardioid

$r = a(1 + \cos\theta)$  about the initial line using double integral.

$$\text{Sol: W.K.T, } V = \int_{\theta=0}^{\pi} \int_{r=0}^{a(1+\cos\theta)} 2\pi r^2 \sin\theta \, dr \, d\theta$$

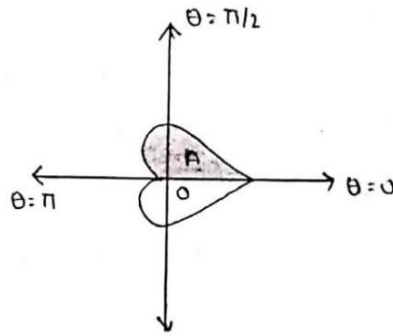

$$\begin{aligned}
 V &= \int_{\theta=0}^{\pi} 2\pi \sin\theta \left[ \frac{r^3}{3} \right]_0^{a(1+\cos\theta)} d\theta \\
 &= \frac{2\pi}{3} \int_{\theta=0}^{\pi} \sin\theta a^3 (1+\cos\theta)^3 d\theta \\
 &= \frac{2a^3\pi}{3} \int_{\theta=0}^{\pi} \sin\theta (1+\cos\theta)^3 d\theta
 \end{aligned}$$

Put  $1 + \cos\theta = t \Rightarrow -\sin\theta d\theta = dt \Rightarrow \sin\theta d\theta = -dt$   
 if  $\theta$  varies from 0 to  $\pi$  then  $t$  also varies from 2 to 0

$$\begin{aligned}
 V &= \frac{2a^3\pi}{3} \int_{t=2}^0 t^3 (-dt)t^3 \cdot -dt \\
 &= \frac{-2a^3\pi}{3} \left[ \frac{t^4}{4} \right]_2^0 \\
 &= \frac{-a^3\pi}{6} (0 - 16) \\
 \therefore V &= \frac{8a^3\pi}{3} \text{ cubic units}
 \end{aligned}$$

5. Find the volume bounded by the cylinder  $x^2 + y^2 = 4$

and the planes  $y + z = 4, z = 0$

**Sol:** volume bounded by the cylinder is given by  $\iiint_V dx dy dz$

Given  $y + z = 4$  gives  $z = 4 - y$  hence  $z$  varies from 0 to  $4 - y$

also  $x^2 + y^2 = 4 \Rightarrow y^2 = 4 - x^2 \Rightarrow y = \pm\sqrt{4 - x^2}$

hence  $y$  varies from  $-\sqrt{4 - x^2}$  to  $\sqrt{4 - x^2}$

consider  $x^2 + y^2 = 4$  further  $y = 0$  and  $x^2 = 4$

$x$  varies from  $-2$  to  $2$

$$\text{i. e., } V = \int_{x=-2}^2 \int_{y=-\sqrt{4-x^2}}^{\sqrt{4-x^2}} \int_{z=0}^{4-y} dz dy dx$$

$$\begin{aligned}
&= \int_{x=-2}^2 \int_{y=-\sqrt{4-x^2}}^{\sqrt{4-x^2}} [z]_0^{4-y} dy dx \\
&= \int_{x=-2}^2 \int_{y=-\sqrt{4-x^2}}^{\sqrt{4-x^2}} (4-y) dy dx \\
&= \int_{x=-2}^2 \left[ 4y - \frac{y^2}{2} \right]_{-\sqrt{4-x^2}}^{\sqrt{4-x^2}} dx \\
&= \int_{x=-2}^2 8\sqrt{4-x^2} dx \\
&= 2 \int_{x=0}^2 8\sqrt{4-x^2} dx \\
&= 16 \int_{x=0}^2 \sqrt{4-x^2} dx \\
&= 16 \left[ \frac{x}{2} \sqrt{4-x^2} + \frac{4}{2} \sin^{-1} \left( \frac{x}{2} \right) \right]_0^2 \\
&= 16 [ 2 \sin^{-1}(1) ] \\
&= 32 \frac{\pi}{2}
\end{aligned}$$

$\therefore V = 16\pi$  cubic units

### Beta and Gamma functions:

Gamma functions is defined as:  $\Gamma(n) = \int_0^{\infty} e^{-x} x^{n-1} dx$ , ( $n > 0$ ) -----(1)

and Beta function is defined as  $\beta(m, n) = \int_0^1 x^{m-1} (1-x)^{n-1} dx$ , ( $m, n > 0$ ) -----(2)

**Alternative form:** Put  $x = t^2$ . Then  $dx = 2t dt$ ,  $t$  also varies from 0 to  $\infty$

$$\therefore \Gamma(n) = \int_{t=0}^{\infty} e^{-t^2} (t^2)^{n-1} 2t dt = 2 \int_0^{\infty} e^{-t^2} t^{2n-1} dt = 2 \int_0^{\infty} e^{-x^2} x^{2n-1} dx$$
 ----- (3) is the alternative form

of Gamma function.

Put  $x = \sin^2 \theta \Rightarrow dx = 2 \sin \theta \cos \theta d\theta$ .

If  $x = 0$ ,  $\sin^2 \theta = 0 \Rightarrow \theta = 0$  & if  $x = 1$ ,  $\sin^2 \theta = 1 \Rightarrow \theta = \pi/2$

$$\therefore \beta(m, n) = \int_{\theta=0}^{\pi/2} (\sin^2 \theta)^{m-1} (\cos^2 \theta)^{n-1} 2 \sin \theta \cos \theta d\theta = 2 \int_0^{\pi/2} \sin^{2m-1} \theta \cos^{2n-1} \theta d\theta$$
 ----- (4) is

alternative form of Beta function.

### Properties of Gamma and Beta functions:

1. (i)  $\Gamma(n+1) = n\Gamma(n)$  (ii)  $\Gamma(n+1) = n!$  for a positive integer  $n$
2.  $\beta(m, n) = \beta(n, m)$

3. Relationship between Beta and Gamma functions :  $\beta(m, n) = \frac{\Gamma(m)\Gamma(n)}{\Gamma(m+n)}$

4. To show that  $\Gamma(1/2) = \sqrt{\pi}$
5. **Duplication formula:** (i)  $\sqrt{\pi} \Gamma(2m) = 2^{2m-1} \Gamma(m) \Gamma(m+1/2)$   
(ii)  $\beta(m, 1/2) = 2^{2m-1} \beta(m, m)$
6.  $\int_0^{\pi/2} \sin^p \theta \cos^q \theta d\theta = \frac{1}{2} \beta\left(\frac{p+1}{2}, \frac{q+1}{2}\right)$       7.  $\Gamma(1/4) \cdot \Gamma(3/4) = \pi\sqrt{2}$ .

**Relationship between Beta and Gamma functions:**  $\beta(m, n) = \frac{\Gamma(m) \cdot \Gamma(n)}{\Gamma(m+n)}$

*Proof : we have by defn of beta and gamma function*

$$\beta(m, n) = 2 \int_0^{\pi/2} \sin^{2m-1} \theta \cos^{2n-1} \theta d\theta \quad \text{---(1)}$$

$$\Gamma(n) = 2 \int_0^{\infty} e^{-x^2} x^{2n-1} dx \quad \text{---(2)}$$

$$\text{and } \Gamma(m) = 2 \int_0^{\infty} e^{-y^2} y^{2m-1} dy \quad \text{---(3)}$$

$$\text{also } \Gamma(m+n) = 2 \int_0^{\infty} e^{-(r^2)} r^{2(m+n)-1} dr \quad \text{---(4)}$$

$$\text{Now } \Gamma(m) \cdot \Gamma(n) = 2 \int_0^{\infty} \int_0^{\infty} e^{-(x^2+y^2)} x^{2n-1} y^{2m-1} dx dy \quad \text{---(5)}$$

*Let us evaluate RHS by changing into polars*

$$\text{Put } x = r \cos \theta, y = r \sin \theta \Rightarrow dx dy = r dr d\theta$$

$$\therefore x^2 + y^2 = r^2$$

*r varies from 0 to  $\infty$*

*and  $\theta$  varies from 0 to  $\frac{\pi}{2}$*

$$\begin{aligned} \Gamma(m) \cdot \Gamma(n) &= 4 \int_{r=0}^{\infty} \int_{\theta=0}^{\pi/2} e^{-r^2} (r \cos \theta)^{2n-1} (r \sin \theta)^{2m-1} r dr d\theta \\ &= 4 \int_{r=0}^{\infty} \int_{\theta=0}^{\pi/2} e^{-r^2} r^{2(m+n)-1} \cos^{2n-1} \theta \sin^{2m-1} \theta dr d\theta \\ &= \left\{ 2 \int_{r=0}^{\infty} e^{-r^2} r^{2(m+n)-1} dr \right\} \left\{ 2 \int_{\theta=0}^{\pi/2} \cos^{2n-1} \theta \sin^{2m-1} \theta d\theta \right\} \end{aligned}$$

$$\Gamma(m) \cdot \Gamma(n) = \Gamma(m+n) \cdot \beta(m, n) \text{ \{by eqn (4) and (1) respectively\}}$$

$$\text{Thus } \beta(m, n) = \frac{\Gamma(m) \cdot \Gamma(n)}{\Gamma(m+n)}$$

**Prove that  $\Gamma(1/2) = \sqrt{\pi}$  using the definition of  $\Gamma(n)$**

*Proof: we have by defn of gamma function*

$$\Gamma(n) = \int_0^{\infty} e^{-x} x^{n-1} dx \quad \therefore \Gamma(1/2) = \int_0^{\infty} e^{-x} x^{1/2-1} dx$$

$$\Gamma(1/2) = \int_0^{\infty} e^{-x^2} dx \quad \text{and also } \Gamma(1/2) = \int_0^{\infty} e^{-y^2} dy$$

$$\text{Hence } \left\{ \Gamma\left(\frac{1}{2}\right) \right\}^2 = 4 \int_0^{\infty} \int_0^{\infty} e^{-(x^2+y^2)} dx dy$$

$$\text{Put } x = r \cos \theta, y = r \sin \theta \Rightarrow dx dy = r dr d\theta$$

$$\therefore x^2 + y^2 = r^2$$

*r varies from 0 to  $\infty$*

*and  $\theta$  varies from 0 to  $\frac{\pi}{2}$*

$$\left\{ \Gamma\left(\frac{1}{2}\right) \right\}^2 = 4 \int_0^{\frac{\pi}{2}} \int_0^{\infty} e^{-r^2} r dr d\theta$$

$$\text{Put } r^2 = t \Rightarrow 2r dr = dt \Rightarrow r dr = \frac{dt}{2}$$

*and t also varies from 0 to  $\infty$*

$$= 4 \int_0^{\frac{\pi}{2}} \int_{t=0}^{\infty} e^{-t} \frac{dt}{2} d\theta$$

$$= 2 \int_0^{\frac{\pi}{2}} - (e^{-t})_0^{\infty} d\theta = 2 \int_0^{\frac{\pi}{2}} 1 \cdot d\theta = 2 [\theta]_0^{\frac{\pi}{2}} = 2 \cdot \frac{\pi}{2} = \pi$$

$$\text{Thus } \left\{ \Gamma\left(\frac{1}{2}\right) \right\}^2 = \pi$$

$$\therefore \Gamma(1/2) = \sqrt{\pi}$$

## Problems

1. Evaluate  $\int_0^{\infty} x^{3/2} e^{-x} dx$

Sol: Let  $I = \int_0^{\infty} x^{3/2} e^{-x} dx$

We have  $\Gamma(n) = \int_0^{\infty} e^{-x} x^{n-1} dx, (n > 0)$  here  $n - 1 = \frac{3}{2}$  or  $n = \frac{5}{2}$

$$I = \Gamma\left(\frac{5}{2}\right)$$

$$= \left(\frac{5}{2} - 1\right) \left(\frac{5}{2} - 2\right) \Gamma\left(\frac{1}{2}\right)$$

$$I = \frac{3}{2} * \frac{1}{2} * \sqrt{\pi}$$

$$I = \frac{3}{4} \sqrt{\pi}$$

2. Evaluate  $\int_0^1 x^{\frac{3}{2}} (1-x)^{\frac{1}{2}} dx$

by expressing in terms of  $\beta$  and  $\Gamma$  function.

Sol: We have  $\beta(m, n) = \int_0^1 x^{m-1} (1-x)^{n-1} dx$ , ( $m, n > 0$ )

$$\text{here } m - 1 = \frac{3}{2} \text{ or } m = \frac{5}{2} \quad \text{and} \quad n - 1 = \frac{1}{2} \text{ or } n = \frac{3}{2}$$

$$\int_0^1 x^{\frac{3}{2}} (1-x)^{\frac{1}{2}} dx = \beta\left(\frac{5}{2}, \frac{3}{2}\right)$$

$$\text{as WKT } \beta(m, n) = \frac{\Gamma(m) \cdot \Gamma(n)}{\Gamma(m+n)}$$

$$\int_0^1 x^{\frac{3}{2}} (1-x)^{\frac{1}{2}} dx = \beta\left(\frac{5}{2}, \frac{3}{2}\right) = \frac{\Gamma(5/2) \cdot \Gamma(3/2)}{\Gamma(5/2 + 3/2)} = \frac{\Gamma(5/2) \cdot \Gamma(3/2)}{\Gamma(4)}$$

$$= \frac{\frac{3}{2} * \frac{1}{2} * \sqrt{\pi} * \frac{1}{2} * \sqrt{\pi}}{3!} = \frac{\pi}{16}$$

3. Show that  $\int_0^{\frac{\pi}{2}} \frac{d\theta}{\sqrt{\sin\theta}} \int_0^{\frac{\pi}{2}} \sqrt{\sin\theta} d\theta = \pi$

$$\text{Sol: Let } I_1 = \int_0^{\frac{\pi}{2}} \frac{d\theta}{\sqrt{\sin\theta}} = \int_0^{\frac{\pi}{2}} \sin^{-1/2}\theta d\theta = \int_0^{\frac{\pi}{2}} \sin^{-1/2}\theta \cos^0\theta d\theta$$

$$\text{and } I_2 = \int_0^{\frac{\pi}{2}} \sqrt{\sin\theta} d\theta = \int_0^{\frac{\pi}{2}} \sin^{1/2}\theta d\theta = \int_0^{\frac{\pi}{2}} \sin^{1/2}\theta \cos^0\theta d\theta$$

We have 
$$\int_0^{\frac{\pi}{2}} \sin^p \theta \cos^q \theta d\theta = \frac{1}{2} \beta \left( \frac{p+1}{2}, \frac{q+1}{2} \right)$$

Hence 
$$I_1 = \int_0^{\frac{\pi}{2}} \sin^{-1/2} \theta \cos^0 \theta d\theta = \frac{1}{2} \beta \left( \frac{-\frac{1}{2}+1}{2}, \frac{0+1}{2} \right) = \frac{1}{2} \beta \left( \frac{1}{4}, \frac{1}{2} \right)$$

similarly 
$$I_2 = \int_0^{\frac{\pi}{2}} \sin^{1/2} \theta \cos^0 \theta d\theta = \frac{1}{2} \beta \left( \frac{\frac{1}{2}+1}{2}, \frac{0+1}{2} \right) = \frac{1}{2} \beta \left( \frac{3}{4}, \frac{1}{2} \right)$$

$$\begin{aligned} \therefore I_1 * I_2 &= \frac{1}{2} \beta \left( \frac{1}{4}, \frac{1}{2} \right) * \frac{1}{2} \beta \left( \frac{3}{4}, \frac{1}{2} \right) \\ &= \frac{1}{2} \frac{\Gamma(1/4) \cdot \Gamma(1/2)}{\Gamma(3/4)} * \frac{\Gamma(3/4) \cdot \Gamma(1/2)}{\Gamma(5/4)} = \pi \end{aligned}$$

$$\therefore \int_0^{\frac{\pi}{2}} \frac{d\theta}{\sqrt{\sin\theta}} \int_0^{\frac{\pi}{2}} \sqrt{\sin\theta} d\theta = \pi$$

4. Show that 
$$\int_0^{\frac{\pi}{2}} \sqrt{\tan\theta} d\theta = \pi/\sqrt{2}$$

Sol: Let 
$$I = \int_0^{\frac{\pi}{2}} \frac{\sqrt{\sin\theta}}{\sqrt{\cos\theta}} d\theta = \int_0^{\frac{\pi}{2}} \sin^{1/2} \theta \cos^{-1/2} \theta d\theta$$

$$\begin{aligned} &= \frac{1}{2} \beta \left( \frac{\frac{1}{2}+1}{2}, \frac{-1/2+1}{2} \right) = \frac{1}{2} \beta \left( \frac{3}{4}, \frac{1}{4} \right) = \frac{1}{2} \frac{\Gamma(\frac{3}{4}) \cdot \Gamma(\frac{1}{4})}{\Gamma(1)} \\ &= \frac{1}{2} \pi \sqrt{2} = \pi/\sqrt{2} \end{aligned}$$

5. Expressing the following function in terms of  $\beta$  function.

Sol: Let 
$$I = \int_0^2 (4-x^2)^{\frac{3}{2}} dx$$

put  $x = 2\sin\theta$   $dx = 2\cos\theta d\theta$

If  $x = 0 \Rightarrow \theta = 0$

If  $x = 2 \Rightarrow \theta = \frac{\pi}{2}$

$$= \int_0^{\frac{\pi}{2}} (4 - 4\sin^2\theta)^{\frac{3}{2}} 2\cos\theta d\theta$$

$$\begin{aligned}
&= \int_0^{\frac{\pi}{2}} (4[1 - \sin^2\theta])^{\frac{3}{2}} 2\cos\theta \, d\theta \\
&= \int_0^{\frac{\pi}{2}} (2^2[1 - \sin^2\theta])^{\frac{3}{2}} 2\cos\theta \, d\theta \\
&= \int_0^{\frac{\pi}{2}} 16 (\cos^2\theta)^{\frac{3}{2}} \cos\theta \, d\theta \\
&= \int_0^{\frac{\pi}{2}} 16 \cos^4\theta \, d\theta \\
&= 16 \int_0^{\frac{\pi}{2}} \sin^0\theta \cos^4\theta \, d\theta \\
&= 16 \frac{1}{2} \beta\left(\frac{0+1}{2}, \frac{4+1}{2}\right) = 8 \beta\left(\frac{1}{2}, \frac{5}{2}\right) = 8 \frac{\Gamma\left(\frac{1}{2}\right) \cdot \Gamma\left(\frac{5}{2}\right)}{\Gamma(3)} \\
&= 8 \frac{\sqrt{\pi} * \frac{3}{2} * \frac{1}{2} * \sqrt{\pi}}{2!} = \frac{2\pi * 3}{2} = 3\pi \\
\therefore I &= 3\pi
\end{aligned}$$

6. Show that  $\beta(m, n) = \int_0^{\infty} \frac{x^{m-1}}{(1+x)^{m+n}} dx$

consider  $\int_0^{\infty} \frac{x^{m-1}}{(1+x)^{m+n}} dx$

put  $x = \tan^2\theta \quad dx = 2\tan\theta \sec^2\theta d\theta$

If  $x = 0 \Rightarrow \theta = 0$

If  $x = \infty \Rightarrow \theta = \frac{\pi}{2}$

$$\begin{aligned}
&\text{i. e., } \int_0^{\frac{\pi}{2}} \frac{\tan^{2m-2}\theta}{(1 + \tan^2\theta)^{m+n}} 2\tan\theta \sec^2\theta \, d\theta \\
&= 2 \int_0^{\frac{\pi}{2}} \frac{\tan^{2m-2+1}\theta}{(\sec^2\theta)^{m+n} \sec^{-2}\theta} \, d\theta
\end{aligned}$$

$$\begin{aligned}
&= 2 \int_0^{\frac{\pi}{2}} \frac{\tan^{2m-1}\theta}{\sec^{2m+2n-2}\theta} d\theta \\
&= 2 \int_0^{\frac{\pi}{2}} \frac{\sin^{2m-1}\theta}{\cos^{2m-1}\theta} \cos^{2m-1}\theta \cos^{2n-1}\theta d\theta \\
&= 2 \int_0^{\frac{\pi}{2}} \sin^{2m-1}\theta \cos^{2n-1}\theta d\theta = \beta(m, n) \\
&\quad \therefore \beta(m, n) = \int_0^{\infty} \frac{x^{m-1}}{(1+x)^{m+n}} dx
\end{aligned}$$

## MODULE-2

### VECTOR CALCULUS

Vector calculus is a field of mathematics concerned with multivariate real analysis of vectors in two or more dimensions. It consists of set of problems solving techniques very useful for engineering and physics.

#### SCALAR AND VECTOR POINT FUNCTIONS

Let  $\vec{F}(t) = f_1(t)\hat{i} + f_2(t)\hat{j} + f_3(t)\hat{k}$  be a 'Vector function'. Then for various values of  $t$  we get a set of constant vectors.

Let  $\varphi = \varphi(x, y, z)$  be a 'Scalar function'. Then for various values of  $x, y, z$  we get a set of points or scalars.

Vector operation  $\nabla$  (*del*) is defined by the equation

$$\nabla = \frac{\partial}{\partial x}\hat{i} + \frac{\partial}{\partial y}\hat{j} + \frac{\partial}{\partial z}\hat{k}$$

This operator has a great role in vector calculus. Laplacian operator  $\nabla^2$  is defined as follows

$$\begin{aligned}\nabla^2 &= \nabla \cdot \nabla = \left( \frac{\partial}{\partial x}\hat{i} + \frac{\partial}{\partial y}\hat{j} + \frac{\partial}{\partial z}\hat{k} \right) \cdot \left( \frac{\partial}{\partial x}\hat{i} + \frac{\partial}{\partial y}\hat{j} + \frac{\partial}{\partial z}\hat{k} \right) \\ \nabla^2 &= \frac{\partial^2}{\partial x^2} + \frac{\partial^2}{\partial y^2} + \frac{\partial^2}{\partial z^2}\end{aligned}$$

#### Gradient

The vector function  $\nabla\varphi$  is defined as the gradient of the scalar function  $\varphi = \varphi(x, y, z)$

$$i. e., \text{grad}\varphi = \nabla\varphi = \left( \frac{\partial}{\partial x}\hat{i} + \frac{\partial}{\partial y}\hat{j} + \frac{\partial}{\partial z}\hat{k} \right) \varphi$$

$$\text{grad}\varphi = \nabla\varphi = \left( \frac{\partial\varphi}{\partial x}\hat{i} + \frac{\partial\varphi}{\partial y}\hat{j} + \frac{\partial\varphi}{\partial z}\hat{k} \right)$$

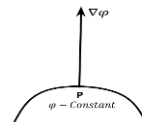

Geometrically,  $\nabla\varphi$  represents a normal at any point P to the surface  $\varphi(x, y, z) = \text{constant}$  and has a magnitude equal to the rate of change of  $\varphi(x, y, z)$  along this normal.  $\nabla\varphi$  is a **vector quantity**.

#### Note:

- The unit normal vector  $\hat{n}$  along  $\nabla\varphi$  is given by  $\hat{n} = \frac{\nabla\varphi}{|\nabla\varphi|}$  or  $\hat{n} = \frac{\nabla f}{|\nabla f|}$
- The component of  $\nabla\varphi$  in the direction of a unit vector  $\vec{a}$  is  $\nabla\varphi \cdot \hat{n}$  and is called the *directional derivative* of  $\varphi$  in the direction of  $\vec{a}$ . Thus, the directional derivative is maximum in the direction  $\nabla\varphi$  and the magnitude of this maximum is equal to  $|\nabla\varphi|$ .  
i. e.,  $\mathbf{D} \cdot \mathbf{D} = \nabla\varphi \cdot \hat{n}$  where  $\hat{n} = \frac{\vec{a}}{|\vec{a}|}$

## Problems

1. Find the unit normal vector to the surface  $x^3 + y^3 + 3xyz = 3$  at  $(1, 2, -1)$ .

**Sol:** Let  $\varphi = x^3 + y^3 + 3xyz - 3$

$$\frac{\partial \varphi}{\partial x} = 3x^2 + 3yz \quad \frac{\partial \varphi}{\partial y} = 3y^2 + 3xz \quad \frac{\partial \varphi}{\partial z} = 3xy$$

$$\text{Now, } \nabla \varphi = \left( \frac{\partial \varphi}{\partial x} \hat{i} + \frac{\partial \varphi}{\partial y} \hat{j} + \frac{\partial \varphi}{\partial z} \hat{k} \right)$$

$$\nabla \varphi = (3x^2 + 3yz)\hat{i} + (3y^2 + 3xz)\hat{j} + (3xy)\hat{k}$$

At  $(1, 2, -1)$

$$\nabla \varphi = (3 - 6)\hat{i} + (12 - 3)\hat{j} + (6)\hat{k}$$

$$\nabla \varphi = -3\hat{i} + 9\hat{j} + 6\hat{k}$$

$$|\nabla \varphi| = \sqrt{(-3)^2 + (9)^2 + (6)^2} = \sqrt{9 + 81 + 36}$$

$$|\nabla \varphi| = \sqrt{126}$$

The unit normal vector,  $\hat{n} = \frac{\nabla \varphi}{|\nabla \varphi|} = \frac{-3\hat{i} + 9\hat{j} + 6\hat{k}}{\sqrt{126}}$

2. Find the unit normal vector to the surface  $x^2y + y^2z + z^2x = 5$  at  $(1, -1, 2)$ .

**Sol:** Let  $\varphi = x^2y + y^2z + z^2x - 5$

$$\frac{\partial \varphi}{\partial x} = 2xy + z^2 \cdot 1 \quad \frac{\partial \varphi}{\partial y} = x^2 \cdot 1 + 2yz \quad \frac{\partial \varphi}{\partial z} = y^2 + 2zx$$

$$\text{Now, } \nabla \varphi = \left( \frac{\partial \varphi}{\partial x} \hat{i} + \frac{\partial \varphi}{\partial y} \hat{j} + \frac{\partial \varphi}{\partial z} \hat{k} \right)$$

$$\nabla \varphi = (2xy + z^2)\hat{i} + (x^2 + 2yz)\hat{j} + (y^2 + 2zx)\hat{k}$$

At  $(1, -1, 2)$

$$\nabla \varphi = (-2 + 4)\hat{i} + (1 - 4)\hat{j} + (1 + 4)\hat{k}$$

$$\nabla \varphi = 2\hat{i} - 3\hat{j} + 5\hat{k}$$

$$|\nabla \varphi| = \sqrt{(2)^2 + (-3)^2 + (5)^2} = \sqrt{4 + 9 + 25}$$

$$|\nabla \varphi| = \sqrt{38}$$

The unit normal vector,  $\hat{n} = \frac{\nabla \varphi}{|\nabla \varphi|} = \frac{2\hat{i} - 3\hat{j} + 5\hat{k}}{\sqrt{38}}$

3. Find the directional derivative of the function  $\varphi = xy^2 + yz^3$  at  $(2, -1, 1)$  along  $\hat{i} + 2\hat{j} + 3\hat{k}$

**Sol:** Given  $\varphi = xy^2 + yz^3$       Let  $\vec{a} = \hat{i} + 2\hat{j} + 3\hat{k}$

$$\frac{\partial \varphi}{\partial x} = 1 \cdot y^2 \qquad \frac{\partial \varphi}{\partial y} = x \cdot 2y + 1 \cdot z^3 \qquad \frac{\partial \varphi}{\partial z} = 0 + y \cdot 3z^2$$

$$\frac{\partial \varphi}{\partial x} = y^2 \qquad \frac{\partial \varphi}{\partial y} = 2xy + z^3 \qquad \frac{\partial \varphi}{\partial z} = 3yz^2$$

$$\text{Now, } \nabla \varphi = \left( \frac{\partial \varphi}{\partial x} \hat{i} + \frac{\partial \varphi}{\partial y} \hat{j} + \frac{\partial \varphi}{\partial z} \hat{k} \right)$$

$$\nabla \varphi = (y^2)\hat{i} + (2xy + z^3)\hat{j} + (3yz^2)\hat{k}$$

At  $(2, -1, 1)$

$$\nabla \varphi = (1)\hat{i} + (-4 + 1)\hat{j} + (-3)\hat{k}$$

$$\nabla \varphi = \hat{i} - 3\hat{j} - 3\hat{k}$$

Also,  $\vec{a} = \hat{i} + 2\hat{j} + 3\hat{k}$

$$|\vec{a}| = \sqrt{1^2 + 2^2 + 3^2}$$

$$|\vec{a}| = \sqrt{1 + 4 + 9}$$

$$|\vec{a}| = \sqrt{14}$$

$$\therefore \hat{n} = \frac{\vec{a}}{|\vec{a}|} = \frac{\hat{i} + 2\hat{j} + 3\hat{k}}{\sqrt{14}}$$

$$D.D = \nabla \varphi \cdot \hat{n}$$

$$D.D = (\hat{i} - 3\hat{j} - 3\hat{k}) \cdot \frac{(\hat{i} + 2\hat{j} + 3\hat{k})}{\sqrt{14}}$$

$$D.D = \frac{(1)(1) + (-3)(2) + (-3)(3)}{\sqrt{14}}$$

$$D.D = \frac{1 - 6 - 9}{\sqrt{14}}$$

$$D.D = \frac{-14}{\sqrt{14}}$$

$$D.D = -\sqrt{14}$$

4. Find the directional derivative of the function  $f = 4xz^3 - 3x^2y^2z$  at  $(2, -1, 2)$  along  $2\hat{i} - 3\hat{j} + 6\hat{k}$

**Sol:** Given  $f = 4xz^3 - 3x^2y^2z$  Let  $\vec{a} = 2\hat{i} - 3\hat{j} + 6\hat{k}$

$$\frac{\partial f}{\partial x} = 4z^3 \cdot 1 - 3y^2z \cdot 2x \qquad \frac{\partial f}{\partial y} = 0 - 3x^2z \cdot 2y \qquad \frac{\partial f}{\partial z} = 4x \cdot 3z^2 - 3x^2y^2 \cdot 1$$

$$\frac{\partial f}{\partial x} = 4z^3 - 6xy^2z \qquad \frac{\partial f}{\partial y} = -6x^2yz \qquad \frac{\partial f}{\partial z} = 12xz^2 - 3x^2y^2$$

Now,  $\nabla f = \left( \frac{\partial f}{\partial x} \hat{i} + \frac{\partial f}{\partial y} \hat{j} + \frac{\partial f}{\partial z} \hat{k} \right)$

$$\nabla f = (4z^3 - 6xy^2z)\hat{i} + (-6x^2yz)\hat{j} + (12xz^2 - 3x^2y^2)\hat{k}$$

At  $(2, -1, 2)$

$$\nabla f = (32 - 24)\hat{i} + (48)\hat{j} + (96 - 12)\hat{k}$$

$$\nabla f = 8\hat{i} + 48\hat{j} + 84\hat{k}$$

Also,  $\vec{a} = 2\hat{i} - 3\hat{j} + 6\hat{k}$

$$|\vec{a}| = \sqrt{2^2 + (-3)^2 + 6^2}$$

$$|\vec{a}| = \sqrt{4 + 9 + 36}$$

$$|\vec{a}| = \sqrt{49}$$

$$|\vec{a}| = 7$$

$$\therefore \hat{n} = \frac{\vec{a}}{|\vec{a}|} = \frac{2\hat{i} - 3\hat{j} + 6\hat{k}}{7}$$

$$D.D = \nabla f \cdot \hat{n}$$

$$D.D = (8\hat{i} + 48\hat{j} + 84\hat{k}) \cdot \frac{(2\hat{i} - 3\hat{j} + 6\hat{k})}{7}$$

$$D.D = \frac{(8)(2) + (48)(-3) + (84)(6)}{7}$$

$$D.D = \frac{16 - 144 + 504}{7}$$

$$D.D = \frac{376}{7}$$

5. Find the directional derivative of  $\varphi = e^{2x} \cos(yz)$  at the origin in the direction of the tangent to the curve  $x = asint$ ,  $y = acost$  and  $z = at$  at  $t = \frac{\pi}{4}$ .

**Sol:** Given  $\varphi = e^{2x} \cos(yz)$

$$\frac{\partial \varphi}{\partial x} = \cos(yz) \cdot 2e^{2x} \quad \frac{\partial \varphi}{\partial y} = e^{2x} [-\sin(yz) \cdot z] \quad \frac{\partial \varphi}{\partial z} = e^{2x} [-\sin(yz) \cdot y]$$

$$\frac{\partial \varphi}{\partial x} = 2e^{2x} \cos(yz) \quad \frac{\partial \varphi}{\partial y} = -e^{2x} z \sin(yz) \quad \frac{\partial \varphi}{\partial z} = -e^{2x} y \sin(yz)$$

$$\text{Now, } \nabla \varphi = \left( \frac{\partial \varphi}{\partial x} \hat{i} + \frac{\partial \varphi}{\partial y} \hat{j} + \frac{\partial \varphi}{\partial z} \hat{k} \right)$$

$$\nabla \varphi = [2e^{2x} \cos(yz)] \hat{i} + [-e^{2x} z \sin(yz)] \hat{j} + [-e^{2x} y \sin(yz)] \hat{k}$$

At origin i.e., (0,0,0)

$$\nabla \varphi = (2) \hat{i} + (0) \hat{j} + (0) \hat{k} \quad (\text{since } e^0 = \cos(0) = 1, \sin(0) = 0)$$

$$\nabla \varphi = 2 \hat{i}$$

Consider,  $\vec{r} = x \hat{i} + y \hat{j} + z \hat{k}$

$$\vec{r} = (asint) \hat{i} + (acost) \hat{j} + (at) \hat{k}$$

$$\frac{d\vec{r}}{dt} = (acost) \hat{i} + (-asint) \hat{j} + (a) \hat{k}$$

At  $t = \frac{\pi}{4}$

$$\frac{d\vec{r}}{dt} = \left( a \cdot \frac{1}{\sqrt{2}} \right) \hat{i} + \left( -a \cdot \frac{1}{\sqrt{2}} \right) \hat{j} + (a) \hat{k}$$

$$\frac{d\vec{r}}{dt} = \left( \frac{a}{\sqrt{2}} \right) \hat{i} - \left( \frac{a}{\sqrt{2}} \right) \hat{j} + (a) \hat{k}$$

Unit normal vector,  $\hat{n} = \frac{\frac{d\vec{r}}{dt}}{\left| \frac{d\vec{r}}{dt} \right|}$

$$\hat{n} = \frac{\left( \frac{a}{\sqrt{2}} \right) \hat{i} - \left( \frac{a}{\sqrt{2}} \right) \hat{j} + (a) \hat{k}}{\sqrt{\left( \frac{a}{\sqrt{2}} \right)^2 + \left( -\frac{a}{\sqrt{2}} \right)^2 + a^2}}$$

$$\hat{n} = \frac{\left(\frac{a}{\sqrt{2}}\right)\hat{i} - \left(\frac{a}{\sqrt{2}}\right)\hat{j} + (a)\hat{k}}{\sqrt{\frac{a^2}{2} + \frac{a^2}{2} + a^2}} = \frac{\left(\frac{a}{\sqrt{2}}\right)\hat{i} - \left(\frac{a}{\sqrt{2}}\right)\hat{j} + (a)\hat{k}}{\sqrt{a^2 + a^2}}$$

$$\hat{n} = \frac{\left(\frac{a}{\sqrt{2}}\right)\hat{i} - \left(\frac{a}{\sqrt{2}}\right)\hat{j} + (a)\hat{k}}{\sqrt{2} \cdot a}$$

$$\hat{n} = \frac{\frac{a}{\sqrt{2}}(\hat{i} - \hat{j} + \sqrt{2}\hat{k})}{\sqrt{2} \cdot a}$$

$$\hat{n} = \frac{(\hat{i} - \hat{j} + \sqrt{2}\hat{k})}{2}$$

$$D \cdot D = \nabla \varphi \cdot \hat{n}$$

$$D \cdot D = 2\hat{i} \cdot \frac{(\hat{i} - \hat{j} + \sqrt{2}\hat{k})}{2}$$

$$D \cdot D = 1$$

6. Find the directional derivative of  $\varphi = xy^2 + yz^3$  at the point  $(2, -1, 1)$  in the direction normal to the surface  $x \log z - y^2 + 4$  at the point  $(-1, 2, 1)$ .

**Sol:** Given  $\varphi = xy^2 + yz^3$

$$\frac{\partial \varphi}{\partial x} = 1 \cdot y^2$$

$$\frac{\partial \varphi}{\partial y} = x \cdot 2y + 1 \cdot z^3$$

$$\frac{\partial \varphi}{\partial z} = 0 + y \cdot 3z^2$$

$$\frac{\partial \varphi}{\partial x} = y^2$$

$$\frac{\partial \varphi}{\partial y} = 2xy + z^3$$

$$\frac{\partial \varphi}{\partial z} = 3yz^2$$

$$\text{Now, } \nabla \varphi = \left( \frac{\partial \varphi}{\partial x} \hat{i} + \frac{\partial \varphi}{\partial y} \hat{j} + \frac{\partial \varphi}{\partial z} \hat{k} \right)$$

$$\nabla \varphi = (y^2)\hat{i} + (2xy + z^3)\hat{j} + (3yz^2)\hat{k}$$

At  $(2, -1, 1)$

$$\nabla \varphi = (1)\hat{i} + (-4 + 1)\hat{j} + (-3)\hat{k}$$

$$\nabla \varphi = \hat{i} - 3\hat{j} - 3\hat{k}$$

Also given  $\psi = x \log z - y^2 + 4$

$$\frac{\partial \psi}{\partial x} = 1 \cdot \log z - 0$$

$$\frac{\partial \psi}{\partial y} = 0 - 2y$$

$$\frac{\partial \psi}{\partial z} = x \cdot \frac{1}{z} - 0$$

$$\frac{\partial \psi}{\partial x} = \log z \quad \frac{\partial \psi}{\partial y} = -2y \quad \frac{\partial \psi}{\partial z} = \frac{x}{z}$$

$$\text{Now, } \nabla \psi = \left( \frac{\partial \psi}{\partial x} \hat{i} + \frac{\partial \psi}{\partial y} \hat{j} + \frac{\partial \psi}{\partial z} \hat{k} \right)$$

$$\nabla \psi = (\log z) \hat{i} + (-2y) \hat{j} + \left( \frac{x}{z} \right) \hat{k}$$

At  $(-1, 2, 1)$

$$\nabla \psi = (\log 1) \hat{i} + (-2 \cdot 2) \hat{j} + \left( \frac{-1}{1} \right) \hat{k}$$

$$\nabla \psi = (0) \hat{i} + (-4) \hat{j} + (-1) \hat{k}$$

$$|\nabla \psi| = \sqrt{(-4)^2 + (-1)^2}$$

$$|\nabla \psi| = \sqrt{17}$$

$$\hat{n} = \frac{\nabla \psi}{|\nabla \psi|} = \frac{0\hat{i} - 4\hat{j} - \hat{k}}{\sqrt{17}}$$

$$D \cdot D = \nabla \phi \cdot \hat{n}$$

$$D \cdot D = \nabla \phi \cdot \frac{\nabla \psi}{|\nabla \psi|}$$

$$D \cdot D = (\hat{i} - 3\hat{j} - 3\hat{k}) \cdot \frac{(0\hat{i} - 4\hat{j} - \hat{k})}{\sqrt{17}}$$

$$D \cdot D = \frac{(1)(0) + (-3)(-4) + (-3)(-1)}{\sqrt{17}}$$

$$D \cdot D = \frac{0 + 12 + 3}{\sqrt{17}}$$

$$D \cdot D = \frac{15}{\sqrt{17}}$$

7. The directional derivative of  $\phi = axy^2 + byz + cz^2x^3$  at the point  $(-1, 1, 2)$  has maximum

magnitude of 32 units in the direction parallel to  $y$  - axis find  $a, b, c$ .

**Sol:** Given  $\phi = axy^2 + byz + cz^2x^3$

$$\frac{\partial \phi}{\partial x} = ay^2 \cdot 1 + 0 + cz^2 \cdot 3x^2 \quad \frac{\partial \phi}{\partial y} = ax \cdot 2y + bz \cdot 1 + 0 \quad \frac{\partial \phi}{\partial z} = 0 + by \cdot 1 + cx^3 \cdot 2z$$

$$\frac{\partial \phi}{\partial x} = ay^2 + 3cz^2x^2 \quad \frac{\partial \phi}{\partial y} = 2axy + bz \quad \frac{\partial \phi}{\partial z} = by + 2czx^3$$

$$\text{Now, } \nabla\varphi = \left( \frac{\partial\varphi}{\partial x}\hat{i} + \frac{\partial\varphi}{\partial y}\hat{j} + \frac{\partial\varphi}{\partial z}\hat{k} \right)$$

$$\nabla\varphi = (ay^2 + 3cz^2x^2)\hat{i} + (2axy + bz)\hat{j} + (by + 2czx^3)\hat{k}$$

At  $(-1,1,2)$

$$\nabla\varphi = (ay^2 + 3cz^2x^2)\hat{i} + (2axy + bz)\hat{j} + (by + 2czx^3)\hat{k}$$

$$\nabla\varphi = (a + 12c)\hat{i} + (-2a + 2b)\hat{j} + (b - 4c)\hat{k}$$

Since the D.D of  $\varphi$  has a maximum magnitude of 32 units in the direction parallel to  $y$  - axis is

$$\nabla\varphi \cdot \hat{j} = 32$$

$$[(a + 12c)\hat{i} + (-2a + 2b)\hat{j} + (b - 4c)\hat{k}] \cdot [0\hat{i} + 1\hat{j} + 0\hat{k}] = 32$$

$$\Rightarrow a + 12c = 0$$

$$-2a + 2b = 32$$

$$b - 4c = 0$$

$$\Rightarrow \mathbf{a} = -12\mathbf{c}$$

$$\Rightarrow b - a = 16$$

$$\Rightarrow \mathbf{b} = 4\mathbf{c}$$

$$\Rightarrow 4c - (-12c) = 16$$

$$\Rightarrow 16c = 16$$

$$\Rightarrow \mathbf{a} = -12$$

$$\Rightarrow \mathbf{c} = 1$$

$$\Rightarrow \mathbf{b} = 4$$

$$\therefore \mathbf{a} = -12, \mathbf{b} = 4, \mathbf{c} = 1$$

8. Find the angle between the surfaces or normal surfaces  $x^2 + y^2 + z^2 = 9$  and  $z = x^2 + y^2 - 3$  at  $(2, -1, 2)$ .

$$\text{Sol: Given } \varphi = x^2 + y^2 + z^2 - 9 \quad \psi = x^2 + y^2 - z - 3$$

$$\frac{\partial\varphi}{\partial x} = 2x$$

$$\frac{\partial\psi}{\partial x} = 2x$$

$$\frac{\partial\varphi}{\partial y} = 2y$$

$$\frac{\partial\psi}{\partial y} = 2y$$

$$\frac{\partial\varphi}{\partial z} = 2z$$

$$\frac{\partial\psi}{\partial z} = -1$$

$$\text{Wkt, } \nabla\varphi = \frac{\partial\varphi}{\partial x}\hat{i} + \frac{\partial\varphi}{\partial y}\hat{j} + \frac{\partial\varphi}{\partial z}\hat{k}$$

$$\nabla\varphi = (2x)\hat{i} + (2y)\hat{j} + (2z)\hat{k}$$

At  $(2, -1, 2)$

$$\nabla\varphi = (2.2)\hat{i} + (2.(-1))\hat{j} + (2.2)\hat{k}$$

$$\nabla\phi = 4\hat{i} - 2\hat{j} + 4\hat{k}$$

$$|\nabla\phi| = \sqrt{4^2 + (-2)^2 + 4^2} = \sqrt{36}$$

$$|\nabla\phi| = 6$$

Also  $\nabla\psi = \frac{\partial\psi}{\partial x}\hat{i} + \frac{\partial\psi}{\partial y}\hat{j} + \frac{\partial\psi}{\partial z}\hat{k}$

$$\nabla\psi = (2x)\hat{i} + (2y)\hat{j} + (-1)\hat{k}$$

At (2, -1, 2)

$$\nabla\psi = (2.2)\hat{i} + (2.(-1))\hat{j} + (-1)\hat{k}$$

$$\nabla\psi = 4\hat{i} - 2\hat{j} - \hat{k}$$

$$|\nabla\psi| = \sqrt{4^2 + (-2)^2 + (-1)^2}$$

$$|\nabla\psi| = \sqrt{21}$$

Angle between surface,

$$\cos\theta = \hat{n}_1 \cdot \hat{n}_2$$

$$\cos\theta = \frac{\nabla\phi}{|\nabla\phi|} \cdot \frac{\nabla\psi}{|\nabla\psi|}$$

$$\cos\theta = \frac{(4\hat{i} - 2\hat{j} + 4\hat{k})}{6} \cdot \frac{(4\hat{i} - 2\hat{j} - \hat{k})}{\sqrt{21}}$$

$$\cos\theta = \frac{16 + 4 - 4}{6\sqrt{21}} = \frac{16}{6\sqrt{21}} \quad \cos\theta = \frac{8}{3\sqrt{21}}$$

$$\theta = \cos^{-1}\left(\frac{8}{3\sqrt{21}}\right)$$

9. Find the angle between the normal to the surface  $xy = z^2$  at the point (4,1,2) & (3,3,-3).

**Sol:** Given  $\phi = xy - z^2$

$$\frac{\partial\phi}{\partial x} = 1 \cdot y - 0$$

$$\frac{\partial\phi}{\partial y} = x \cdot 1 - 0$$

$$\frac{\partial\phi}{\partial z} = 0 - 2z$$

$$\frac{\partial\phi}{\partial x} = y$$

$$\frac{\partial\phi}{\partial y} = x$$

$$\frac{\partial\phi}{\partial z} = -2z$$

$$\text{Wkt, } \nabla\varphi = \frac{\partial\varphi}{\partial x}\hat{i} + \frac{\partial\varphi}{\partial y}\hat{j} + \frac{\partial\varphi}{\partial z}\hat{k}$$

$$\nabla\varphi = (y)\hat{i} + (x)\hat{j} + (-2z)\hat{k}$$

At (4,1,2)

At (3,3,-3)

$$\nabla\varphi_1 = (1)\hat{i} + (4)\hat{j} + (-2.2)\hat{k}$$

$$\nabla\varphi_2 = (3)\hat{i} + (3)\hat{j} + (2.3)\hat{k}$$

$$\nabla\varphi_1 = \hat{i} + 4\hat{j} - 4\hat{k}$$

$$\nabla\varphi_2 = 3\hat{i} + 3\hat{j} + 6\hat{k}$$

$$|\nabla\varphi_1| = \sqrt{1^2 + 4^2 + (-4)^2}$$

$$|\nabla\varphi_2| = \sqrt{3^2 + 3^2 + 6^2} = \sqrt{54}$$

$$|\nabla\varphi_1| = \sqrt{33}$$

$$|\nabla\varphi_2| = 3\sqrt{6}$$

Angle between surface,

$$\cos\theta = \hat{n}_1 \cdot \hat{n}_2$$

$$\cos\theta = \frac{\nabla\varphi_1}{|\nabla\varphi_1|} \cdot \frac{\nabla\varphi_2}{|\nabla\varphi_2|}$$

$$\cos\theta = \frac{(\hat{i}+4\hat{j}-4\hat{k}) \cdot (3\hat{i}+3\hat{j}+6\hat{k})}{\sqrt{33} \cdot 3\sqrt{6}}$$

$$\cos\theta = \frac{3+12-24}{3\sqrt{33.6}} = \frac{-9}{3.3\sqrt{22}}$$

$$\cos\theta = \frac{-1}{\sqrt{22}} \quad ; \quad \theta = \cos^{-1} \left[ \frac{-1}{\sqrt{22}} \right]$$

### Divergence of a vector function

The divergence of a vector function  $\vec{F} = f_1\hat{i} + f_2\hat{j} + f_3\hat{k}$ , where  $f_1, f_2, f_3$  are functions of  $x, y, z$ . It is denoted by  $\text{div}\vec{F}$  and is defined as

$$\text{div}\vec{F} = \nabla \cdot \vec{F}$$

$$\text{div}\vec{F} = \left( \frac{\partial}{\partial x}\hat{i} + \frac{\partial}{\partial y}\hat{j} + \frac{\partial}{\partial z}\hat{k} \right) \cdot (f_1\hat{i} + f_2\hat{j} + f_3\hat{k})$$

$$\text{div}\vec{F} = \nabla \cdot \vec{F} = \frac{\partial f_1}{\partial x} + \frac{\partial f_2}{\partial y} + \frac{\partial f_3}{\partial z}$$

Clearly  $\text{div}\vec{F}$  is a scalar quantity.

### Physical interpretation of Divergence

Let us consider the motion of the fluid. Consider a small rectangular parallelepiped with edges  $\delta_x, \delta_y, \delta_z$  parallel to the axes in the mass of fluid.

Let  $\vec{V} = V_x \hat{i} + V_y \hat{j} + V_z \hat{k}$  be the velocity of the fluid at  $(x, y, z)$ .

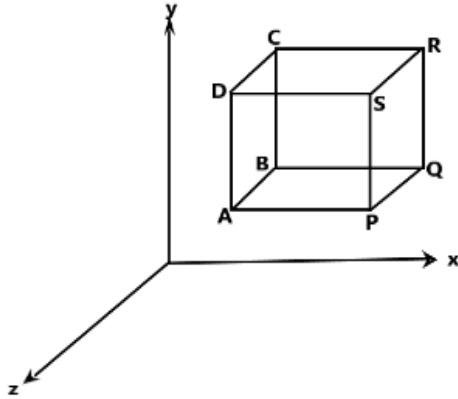

Amount of the fluid flowing in through the face ABCD per unit time  
 = Velocity  $\times$  Area of the face =  $V_x \delta y \delta z$

Amount of the fluid flowing out through the face PQRS per unit time

$$= \left[ V_x + \frac{\partial V_x}{\partial x} \delta x \right] \delta y \delta z$$

$\therefore$  The net decrease in the amount of fluid across these two faces is

$$\begin{aligned} &= \left[ V_x + \frac{\partial V_x}{\partial x} \delta x \right] \delta y \delta z - V_x \delta y \delta z \\ &= \left[ V_x + \frac{\partial V_x}{\partial x} \delta x - V_x \right] \delta y \delta z = \frac{\partial V_x}{\partial x} \delta x \delta y \delta z \end{aligned}$$

Similarly, the decrease in amount of fluid due to flow along the  $y$  – axis =  $\frac{\partial V_y}{\partial y} \delta x \delta y \delta z$

The decrease in amount of fluid due to flow along the  $z$  – axis =  $\frac{\partial V_z}{\partial z} \delta x \delta y \delta z$

Total decrease in amount of fluid inside the parallelepiped per unit time

$$= \left[ \frac{\partial V_x}{\partial x} + \frac{\partial V_y}{\partial y} + \frac{\partial V_z}{\partial z} \right] \delta x \delta y \delta z$$

Hence the ratio of loss of fluid per unit volume =  $\frac{\partial V_x}{\partial x} + \frac{\partial V_y}{\partial y} + \frac{\partial V_z}{\partial z}$

$$\begin{aligned} &= \left[ \frac{\partial}{\partial x} \hat{i} + \frac{\partial}{\partial y} \hat{j} + \frac{\partial}{\partial z} \hat{k} \right] \cdot [V_x \hat{i} + V_y \hat{j} + V_z \hat{k}] \\ &= \nabla \cdot \vec{V} \\ &= \text{div} \vec{V} \end{aligned}$$

Hence  $\text{div}\vec{V}$  gives the rate of outflow per unit volume at a point of the fluid. If  $\text{div}\vec{V} = 0$  everywhere in some region of space, then  $\vec{V}$  is called **Solenoidal Vector function** and the fluids said to be *incompressible* i.e., there is no gain or loss in the volume element.

### Curl of a vector function

The curl of a vector function  $\vec{F} = f_1\hat{i} + f_2\hat{j} + f_3\hat{k}$  is denoted by  $\text{curl}\vec{F}$  and is defined as  $\text{curl}\vec{F} = \nabla \times \vec{F}$

$$\text{curl}\vec{F} = \begin{vmatrix} \hat{i} & \hat{j} & \hat{k} \\ \frac{\partial}{\partial x} & \frac{\partial}{\partial y} & \frac{\partial}{\partial z} \\ f_1 & f_2 & f_3 \end{vmatrix}$$

$$\text{curl}\vec{F} = \left[ \frac{\partial f_3}{\partial y} - \frac{\partial f_2}{\partial z} \right] \hat{i} - \left[ \frac{\partial f_3}{\partial x} - \frac{\partial f_1}{\partial z} \right] \hat{j} + \left[ \frac{\partial f_2}{\partial x} - \frac{\partial f_1}{\partial y} \right] \hat{k}$$

Clearly  $\text{curl}\vec{F}$  is a vector quantity.

### Physical interpretation of Curl

Consider a rigid body rotating about a fixed axis through origin. Let the uniform angular velocity be  $\vec{\omega} = w_1\hat{i} + w_2\hat{j} + w_3\hat{k}$ ,  $w_1, w_2, w_3$  are constants. The velocity  $\vec{V}$  of any point P(x, y, z) on the body is given by  $\vec{V} = \vec{\omega} \times \vec{r}$ , where  $\vec{r}$  is the position vector of P.

Let  $\vec{\omega} = w_1\hat{i} + w_2\hat{j} + w_3\hat{k}$  and  $\vec{r} = x\hat{i} + y\hat{j} + z\hat{k}$

Consider  $\vec{V} = \vec{\omega} \times \vec{r}$

$$= \begin{vmatrix} \hat{i} & \hat{j} & \hat{k} \\ w_1 & w_2 & w_3 \\ x & y & z \end{vmatrix}$$

$$\vec{V} = (w_2z - w_3y)\hat{i} - (w_1z - w_3x)\hat{j} + (w_1y - w_2x)\hat{k}$$

$$\text{curl}\vec{V} = \nabla \times \vec{V}$$

$$\text{curl}\vec{V} = \nabla \times [(w_2z - w_3y)\hat{i} - (w_1z - w_3x)\hat{j} + (w_1y - w_2x)\hat{k}]$$

$$\text{curl}\vec{V} = \begin{vmatrix} \hat{i} & \hat{j} & \hat{k} \\ \frac{\partial}{\partial x} & \frac{\partial}{\partial y} & \frac{\partial}{\partial z} \\ (w_2z - w_3y) & (w_3x - w_1z) & (w_1y - w_2x) \end{vmatrix}$$

$$\text{curl}\vec{V} = [w_1 - (-w_1)]\hat{i} - [-w_2 - w_2]\hat{j} + [w_3 - (-w_3)]\hat{k}$$

$$\text{curl}\vec{V} = [2w_1]\hat{i} + [2w_2]\hat{j} + [2w_3]\hat{k}$$

$$\text{curl}\vec{V} = 2[w_1\hat{i} + w_2\hat{j} + w_3\hat{k}]$$

$$\text{curl}\vec{V} = 2\vec{\omega}$$

$$\vec{\omega} = \frac{1}{2} \text{curl} \vec{V}$$

Thus the angular velocity of rotation at any point is equal to half of the curl of the velocity.

**Note:**

1. If  $\text{div} \vec{F} = \mathbf{0}$ , then we say that  $\vec{F}$  is **Solenoidal** vector.
2. If  $\text{curl} \vec{F} = \mathbf{0}$ , then we say that  $\vec{F}$  is **irrotational** vector.
3. Irrotational vector field is called as conservative field or potential field.
4. When  $\vec{F}$  is irrotational there always exist a scalar point function such that  $\nabla \phi = \vec{F}$ , then  $\phi$  is called a scalar potential of vector  $\vec{F}$ .

**Problems**

1. If  $\vec{F} = xyz\hat{i} + 3x^2y\hat{j} + (xz^2 - y^2z)\hat{k}$ , find the  $\text{div} \vec{F}$  and  $\text{curl} \vec{F}$  at  $(2, -1, 1)$ .

**Sol:** Given  $\vec{F} = xyz\hat{i} + 3x^2y\hat{j} + (xz^2 - y^2z)\hat{k}$

Wkt  $\text{div} \vec{F} = \nabla \cdot \vec{F}$

$$\text{div} \vec{F} = \frac{\partial f_1}{\partial x} + \frac{\partial f_2}{\partial y} + \frac{\partial f_3}{\partial z}$$

$$\text{div} \vec{F} = \frac{\partial}{\partial x}(xyz) + \frac{\partial}{\partial y}(3x^2y) + \frac{\partial}{\partial z}(xz^2 - y^2z)$$

$$\text{div} \vec{F} = yz \cdot 1 + 3x^2 \cdot 1 + (x \cdot 2z - y^2 \cdot 1)$$

$$\text{div} \vec{F} = yz + 3x^2 + 2xz - y^2$$

At  $(2, -1, 1)$

$$\text{div} \vec{F} = (-1)(1) + 3 \cdot (2)^2 + 2(2)(1) - (-1)^2$$

$$\text{div} \vec{F} = -1 + 12 + 4 - 1$$

$$\text{div} \vec{F} = 14$$

Also,  $\text{curl} \vec{F} = \nabla \times \vec{F}$

$$= \begin{vmatrix} \hat{i} & \hat{j} & \hat{k} \\ \frac{\partial}{\partial x} & \frac{\partial}{\partial y} & \frac{\partial}{\partial z} \\ (xyz) & (3x^2y) & (xz^2 - y^2z) \end{vmatrix}$$

$$\text{curl} \vec{F} = \left[ \frac{\partial}{\partial y}(xz^2 - y^2z) - \frac{\partial}{\partial z}(3x^2y) \right] \hat{i} - \left[ \frac{\partial}{\partial x}(xz^2 - y^2z) - \frac{\partial}{\partial z}(xyz) \right] \hat{j} \\ + \left[ \frac{\partial}{\partial x}(3x^2y) - \frac{\partial}{\partial y}(xyz) \right] \hat{k}$$

$$\text{curl} \vec{F} = [(-2yz) - 0] \hat{i} - [(z^2 - 0) - (xy)] \hat{j} + [(6xy) - (xz)] \hat{k}$$

$$\text{curl} \vec{F} = [-2yz] \hat{i} - [z^2 - xy] \hat{j} + [6xy - xz] \hat{k}$$

At (2,-1,1)

$$\text{curl}\vec{F} = [-2(-1)(1)]\hat{i} - [1^2 - 2(-1)]\hat{j} + [6(2)(-1) - (2)(1)]\hat{k}$$

$$\text{curl}\vec{F} = 2\hat{i} - 3\hat{j} - 14\hat{k}$$

2. Find  $\text{div}\vec{F}$  and  $\text{curl}\vec{F}$  where  $\vec{F} = \text{grad}(x^3 + y^3 + z^3 - 3xyz)$ .

**Sol:** Let  $\varphi = x^3 + y^3 + z^3 - 3xyz$

$$\vec{F} = \text{grad}\varphi$$

$$\vec{F} = \nabla\varphi$$

$$\vec{F} = \frac{\partial\varphi}{\partial x}\hat{i} + \frac{\partial\varphi}{\partial y}\hat{j} + \frac{\partial\varphi}{\partial z}\hat{k}$$

$$\vec{F} = (3x^2 - 3yz)\hat{i} + (3y^2 - 3xz)\hat{j} + (3z^2 - 3xy)\hat{k}$$

Now,  $\text{div}\vec{F} = \nabla \cdot \vec{F}$

$$\text{div}\vec{F} = \frac{\partial}{\partial x}(3x^2 - 3yz) + \frac{\partial}{\partial y}(3y^2 - 3xz) + \frac{\partial}{\partial z}(3z^2 - 3xy)$$

$$\text{div}\vec{F} = (6x - 0) + (6y - 0) + (6z - 0)$$

$$\text{div}\vec{F} = 6x + 6y + 6z$$

$\text{curl}\vec{F} = \nabla \times \vec{F}$

$$\text{curl}\vec{F} = \begin{vmatrix} \hat{i} & \hat{j} & \hat{k} \\ \frac{\partial}{\partial x} & \frac{\partial}{\partial y} & \frac{\partial}{\partial z} \\ (3x^2 - 3yz) & (3y^2 - 3xz) & (3z^2 - 3xy) \end{vmatrix}$$

$$\text{curl}\vec{F} = \left[ \frac{\partial}{\partial y}(3z^2 - 3xy) - \frac{\partial}{\partial z}(3y^2 - 3xz) \right] \hat{i} - \left[ \frac{\partial}{\partial x}(3z^2 - 3xy) - \frac{\partial}{\partial z}(3x^2 - 3yz) \right] \hat{j} \\ + \left[ \frac{\partial}{\partial x}(3y^2 - 3xz) - \frac{\partial}{\partial y}(3x^2 - 3yz) \right] \hat{k}$$

$$\text{curl}\vec{F} = [(0 - 3x) - (0 - 3x)]\hat{i} - [(0 - 3y) - (0 - 3y)]\hat{j} + [(0 - 3z) - (0 - 3z)]\hat{k}$$

$$\text{curl}\vec{F} = [-3x + 3x]\hat{i} - [-3y + 3y]\hat{j} + [-3z + 3z]\hat{k}$$

$$\text{curl}\vec{F} = 0\hat{i} - 0\hat{j} + 0\hat{k}$$

$$\text{curl}\vec{F} = \vec{0}$$

3. If  $\vec{F} = \nabla(xy^3z^2)$ , find  $\text{div}\vec{F}$  and  $\text{curl}\vec{F}$  at (1, -1, 1).

**Sol:** Let  $\varphi = xy^3z^2$

$$\vec{F} = \nabla\varphi$$

$$\vec{F} = \frac{\partial\varphi}{\partial x}\hat{i} + \frac{\partial\varphi}{\partial y}\hat{j} + \frac{\partial\varphi}{\partial z}\hat{k}$$

$$\vec{F} = (y^3 z^2)\hat{i} + (3xy^2 z^2)\hat{j} + (2xy^3 z)\hat{k}$$

Now,  $\text{div}\vec{F} = \nabla \cdot \vec{F}$

$$\text{div}\vec{F} = \frac{\partial}{\partial x}(y^3 z^2) + \frac{\partial}{\partial y}(3xy^2 z^2) + \frac{\partial}{\partial z}(2xy^3 z)$$

$$\text{div}\vec{F} = (0) + (6xyz^2) + (2xy^3)$$

$$\text{div}\vec{F} = 6xyz^2 + 2xy^3$$

At (1, -1, 1)

$$\text{div}\vec{F} = 6(1)(-1)(1)^2 + 2(1)(-1)^3 = -6 - 2$$

$$\text{div}\vec{F} = -8$$

Also,  $\text{curl}\vec{F} = \nabla \times \vec{F}$

$$\text{curl}\vec{F} = \begin{vmatrix} \hat{i} & \hat{j} & \hat{k} \\ \frac{\partial}{\partial x} & \frac{\partial}{\partial y} & \frac{\partial}{\partial z} \\ (y^3 z^2) & (3xy^2 z^2) & (2xy^3 z) \end{vmatrix}$$

$$\text{curl}\vec{F} = \left[ \frac{\partial}{\partial y}(2xy^3 z) - \frac{\partial}{\partial z}(3xy^2 z^2) \right] \hat{i} - \left[ \frac{\partial}{\partial x}(2xy^3 z) - \frac{\partial}{\partial z}(y^3 z^2) \right] \hat{j} \\ + \left[ \frac{\partial}{\partial x}(3xy^2 z^2) - \frac{\partial}{\partial y}(y^3 z^2) \right] \hat{k}$$

$$\text{curl}\vec{F} = [(6xy^2 z^2) - (6xy^2 z^2)]\hat{i} - [(2y^3 z) - (2y^3 z)]\hat{j} + [(3y^2 z^2) - (3y^2 z^2)]\hat{k}$$

$$\text{curl}\vec{F} = 0\hat{i} - 0\hat{j} + 0\hat{k}$$

$$\text{curl}\vec{F} = \vec{0}$$

4. If  $\vec{F} = (3x^2 y - z)\hat{i} + (xz^3 + y^4)\hat{j} - 2x^3 z^2 \hat{k}$ , find  $\text{grad}(\text{div}\vec{F})$  at (2, -1, 0).

**Sol:** Given  $\vec{F} = (3x^2 y - z)\hat{i} + (xz^3 + y^4)\hat{j} - 2x^3 z^2 \hat{k}$

Wkt,  $\text{div}\vec{F} = \nabla \cdot \vec{F}$

$$\text{div}\vec{F} = \frac{\partial}{\partial x}(3x^2 y - z) + \frac{\partial}{\partial y}(xz^3 + y^4) + \frac{\partial}{\partial z}(-2x^3 z^2)$$

$$\text{div}\vec{F} = (6xy) + (0 + 4y^3) + (-4x^3 z)$$

$$\text{div}\vec{F} = 6xy + 4y^3 - 4x^3 z = \varphi \text{ (Say)}$$

$$\frac{\partial \varphi}{\partial x} = 6y - 12x^2 z \quad \frac{\partial \varphi}{\partial y} = 6x + 12y^2 \quad \frac{\partial \varphi}{\partial z} = -4x^3$$

Now,  $\text{grad}(\text{div}\vec{F}) = \text{grad}\varphi$

$$\text{grad}(\text{div}\vec{F}) = \nabla \varphi$$

$$= \frac{\partial \phi}{\partial x} \hat{i} + \frac{\partial \phi}{\partial y} \hat{j} + \frac{\partial \phi}{\partial z} \hat{k}$$

$$\text{grad}(\text{div} \vec{F}) = (6y - 12x^2z)\hat{i} + (6x + 12y^2)\hat{j} + (-4x^3)\hat{k}$$

At (2, -1, 0)

$$\text{grad}(\text{div} \vec{F}) = (6(-1) - 0)\hat{i} + (6(2) + 12(-1)^2)\hat{j} + (-4(2)^3)\hat{k}$$

$$\text{grad}(\text{div} \vec{F}) = 6\hat{i} + 24\hat{j} - 32\hat{k}$$

6. If  $\vec{F} = x^2\hat{i} + xy\hat{j} + xz\hat{k}$ , find  $\text{curl}(\text{curl} \vec{F})$ .

**Sol:** Given  $\vec{F} = x^2\hat{i} + xy\hat{j} + xz\hat{k}$

$$\text{curl} \vec{F} = \nabla \times \vec{F} = \begin{vmatrix} \hat{i} & \hat{j} & \hat{k} \\ \frac{\partial}{\partial x} & \frac{\partial}{\partial y} & \frac{\partial}{\partial z} \\ (x^2) & (xy) & (xz) \end{vmatrix}$$

$$\text{curl} \vec{F} = \left[ \frac{\partial}{\partial y}(xz) - \frac{\partial}{\partial z}(xy) \right] \hat{i} - \left[ \frac{\partial}{\partial x}(xz) - \frac{\partial}{\partial z}(x^2) \right] \hat{j} + \left[ \frac{\partial}{\partial x}(xy) - \frac{\partial}{\partial y}(x^2) \right] \hat{k}$$

$$\text{curl} \vec{F} = [(0) - (0)]\hat{i} - [(z) - (0)]\hat{j} + [(y) - (0)]\hat{k}$$

$$\text{curl} \vec{F} = 0\hat{i} - z\hat{j} + y\hat{k}$$

Now,

$$\text{curl}(\text{curl} \vec{F}) = \nabla \times (\text{curl} \vec{F})$$

$$\text{curl}(\text{curl} \vec{F}) = \begin{vmatrix} \hat{i} & \hat{j} & \hat{k} \\ \frac{\partial}{\partial x} & \frac{\partial}{\partial y} & \frac{\partial}{\partial z} \\ (0) & (-z) & (y) \end{vmatrix}$$

$$\text{curl}(\text{curl} \vec{F}) = \left[ \frac{\partial}{\partial y}(y) - \frac{\partial}{\partial z}(-z) \right] \hat{i} - \left[ \frac{\partial}{\partial x}(y) - \frac{\partial}{\partial z}(0) \right] \hat{j} + \left[ \frac{\partial}{\partial x}(-z) - \frac{\partial}{\partial y}(0) \right] \hat{k}$$

$$\text{curl}(\text{curl} \vec{F}) = [(1) - (-1)]\hat{i} - [(0) - (0)]\hat{j} + [(0) - (0)]\hat{k}$$

$$\text{curl}(\text{curl} \vec{F}) = 2\hat{i}$$

7. Show that  $\vec{F} = \frac{x\hat{i} + y\hat{j}}{(x^2 + y^2)}$  is both solenoidal and irrotational.

**Sol:** Given  $\vec{F} = \frac{x}{(x^2 + y^2)}\hat{i} + \frac{y}{(x^2 + y^2)}\hat{j}$

Wkt,  $\text{div} \vec{F} = \nabla \cdot \vec{F}$

$$\text{div} \vec{F} = \frac{\partial}{\partial x} \left( \frac{x}{(x^2 + y^2)} \right) + \frac{\partial}{\partial y} \left( \frac{y}{(x^2 + y^2)} \right)$$

$$\text{div} \vec{F} = \frac{(x^2 + y^2) \cdot 1 - x \cdot 2x}{(x^2 + y^2)^2} + \frac{(x^2 + y^2) \cdot 1 - y \cdot 2y}{(x^2 + y^2)^2}$$

$$\operatorname{div} \vec{F} = \frac{x^2+y^2-2x^2+x^2+y^2-2y^2}{(x^2+y^2)^2}$$

$$\operatorname{div} \vec{F} = 0$$

$\therefore \vec{F}$  is Solenoidal.

Now,  $\operatorname{curl} \vec{F} = \nabla \times \vec{F}$

$$\operatorname{curl} \vec{F} = \begin{vmatrix} \hat{i} & \hat{j} & \hat{k} \\ \frac{\partial}{\partial x} & \frac{\partial}{\partial y} & \frac{\partial}{\partial z} \\ \frac{x}{(x^2+y^2)} & \frac{y}{(x^2+y^2)} & 0 \end{vmatrix}$$

$$\operatorname{curl} \vec{F} = \left[ \frac{\partial}{\partial y}(0) - \frac{\partial}{\partial z} \left( \frac{y}{(x^2+y^2)} \right) \right] \hat{i} - \left[ \frac{\partial}{\partial x}(0) - \frac{\partial}{\partial z} \left( \frac{x}{(x^2+y^2)} \right) \right] \hat{j} \\ + \left[ \frac{\partial}{\partial x} \left( \frac{y}{(x^2+y^2)} \right) - \frac{\partial}{\partial y} \left( \frac{x}{(x^2+y^2)} \right) \right] \hat{k}$$

$$\operatorname{curl} \vec{F} = [(0) - (0)]\hat{i} - [(0) - (0)]\hat{j} + \left[ \frac{-2xy}{(x^2+y^2)^2} + \frac{2xy}{(x^2+y^2)^2} \right] \hat{k}$$

$$\operatorname{curl} \vec{F} = 0\hat{i} - 0\hat{j} + 0\hat{k}$$

$$\operatorname{curl} \vec{F} = \vec{0}$$

$\therefore \vec{F}$  is irrotational.

8.  $P.T \vec{F} = (y+z)\hat{i} + (z+x)\hat{j} + (x+y)\hat{k}$  is irrotational. Also find a scalar point function  $\varphi$  such that  $\vec{F} = \nabla\varphi$ .

**Sol:** Given  $\vec{F} = (y+z)\hat{i} + (z+x)\hat{j} + (x+y)\hat{k}$

$$\operatorname{curl} \vec{F} = \nabla \times \vec{F}$$

$$\operatorname{curl} \vec{F} = \begin{vmatrix} \hat{i} & \hat{j} & \hat{k} \\ \frac{\partial}{\partial x} & \frac{\partial}{\partial y} & \frac{\partial}{\partial z} \\ (y+z) & (z+x) & (x+y) \end{vmatrix}$$

$$\operatorname{curl} \vec{F} = \left[ \frac{\partial}{\partial y}(x+y) - \frac{\partial}{\partial z}(z+x) \right] \hat{i} - \left[ \frac{\partial}{\partial x}(x+y) - \frac{\partial}{\partial z}(y+z) \right] \hat{j} \\ + \left[ \frac{\partial}{\partial x}(z+x) - \frac{\partial}{\partial y}(y+z) \right] \hat{k}$$

$$\operatorname{curl} \vec{F} = [(1) - (1)]\hat{i} - [(1) - (1)]\hat{j} + [(1) - (1)]\hat{k}$$

$$\operatorname{curl} \vec{F} = 0\hat{i} - 0\hat{j} + 0\hat{k}$$

$$\operatorname{curl} \vec{F} = \vec{0} \therefore \vec{F} \text{ is irrotational.}$$

**To find  $\varphi$**

Consider  $\nabla\varphi = \vec{F}$

$$\frac{\partial\varphi}{\partial x}\hat{i} + \frac{\partial\varphi}{\partial y}\hat{j} + \frac{\partial\varphi}{\partial z}\hat{k} = (y+z)\hat{i} + (z+x)\hat{j} + (x+y)\hat{k}$$

$$\frac{\partial\varphi}{\partial x} = y+z \quad \frac{\partial\varphi}{\partial y} = z+x \quad \frac{\partial\varphi}{\partial z} = x+y$$

Integrating we get

$$\varphi = (y+z) \int 1 dx \quad \varphi = (z+x) \int 1 dy \quad \varphi = (x+y) \int 1 dz$$

$$\varphi = (y+z)x + f(y,z) \quad \varphi = (z+x)y + f(x,z) \quad \varphi = (x+y)z + f(x,y)$$

$$\varphi = xy + xz + f(y,z) \quad \varphi = yz + xy + f(x,z) \quad \varphi = xz + yz + f(x,y)$$

$\therefore \varphi = xy + xz + yz$ , where  $f(y,z) = yz$ ,  $f(x,z) = xz$ ,  $f(x,y) = xy$

9. If  $\vec{F} = (axy + z^3)\hat{i} + (3x^2 - z)\hat{j} + (bxz^2 - y)\hat{k}$ ; if  $\vec{F}$  is irrotational find constants  $a$  and  $b$ . Also find scalar function  $\varphi$  such that  $\vec{F} = \nabla\varphi$ .

**Sol:** Given  $\vec{F} = (axy + z^3)\hat{i} + (3x^2 - z)\hat{j} + (bxz^2 - y)\hat{k}$

$$\text{curl}\vec{F} = \nabla \times \vec{F}$$

$$\text{curl}\vec{F} = \begin{vmatrix} \hat{i} & \hat{j} & \hat{k} \\ \frac{\partial}{\partial x} & \frac{\partial}{\partial y} & \frac{\partial}{\partial z} \\ (axy + z^3) & (3x^2 - z) & (bxz^2 - y) \end{vmatrix}$$

$$\text{curl}\vec{F} = \left[ \frac{\partial}{\partial y}(bxz^2 - y) - \frac{\partial}{\partial z}(3x^2 - z) \right] \hat{i} - \left[ \frac{\partial}{\partial x}(bxz^2 - y) - \frac{\partial}{\partial z}(axy + z^3) \right] \hat{j} + \left[ \frac{\partial}{\partial x}(3x^2 - z) - \frac{\partial}{\partial y}(axy + z^3) \right] \hat{k}$$

$$\text{curl}\vec{F} = [(-1) - (-1)]\hat{i} - [(bz^2) - (3z^2)]\hat{j} + [(6x) - (ax)]\hat{k}$$

$$= 0\hat{i} - (bz^2 - 3z^2)\hat{j} + (6x - ax)\hat{k}$$

Since  $\vec{F}$  is irrotational,

$$\text{curl}\vec{F} = \vec{0}$$

$$0\hat{i} - (bz^2 - 3z^2)\hat{j} + (6x - ax)\hat{k} = 0\hat{i} - 0\hat{j} + 0\hat{k}$$

$$bz^2 - 3z^2 = 0 \quad 6x - ax = 0$$

$$z^2(b - 3) = 0 \quad x(6 - a) = 0$$

$$b - 3 = 0 \quad 6 - a = 0$$

$$\mathbf{b = 3} \quad \mathbf{a = 6}$$

Thus,  $\vec{F} = (6xy + z^3)\hat{i} + (3x^2 - z)\hat{j} + (3xz^2 - y)\hat{k}$

**To find  $\varphi$**

Consider  $\nabla\varphi = \vec{F}$

$$\frac{\partial\varphi}{\partial x}\hat{i} + \frac{\partial\varphi}{\partial y}\hat{j} + \frac{\partial\varphi}{\partial z}\hat{k} = (6xy + z^3)\hat{i} + (3x^2 - z)\hat{j} + (3xz^2 - y)\hat{k}$$

$$\frac{\partial\varphi}{\partial x} = 6xy + z^3 \quad \frac{\partial\varphi}{\partial y} = 3x^2 - z \quad \frac{\partial\varphi}{\partial z} = 3xz^2 - y$$

Integrating we get

$$\begin{aligned} \varphi &= 6y \int x \, dx + z^3 \int 1 \, dx & \varphi &= 3x^2 \int 1 \, dy - z \int 1 \, dy & \varphi &= \\ &3x \int z^2 \, dz - y \int 1 \, dz \end{aligned}$$

$$\varphi = 6y \left(\frac{x^2}{2}\right) + z^3 x + f(y, z) \quad \varphi = 3x^2 y - zy + f(x, z) \quad \varphi = 3x \left(\frac{z^3}{3}\right) - yz + f(x, y)$$

$$\varphi = 3x^2 y + z^3 x + f(y, z) \quad \varphi = 3x^2 y - zy + f(x, z) \quad \varphi = xz^3 - yz + f(x, y)$$

$$\therefore \varphi = 3x^2 y + xz^3 - yz, \text{ where } f(y, z) = -yz, f(x, z) = xz^3, f(x, y) = 3x^2 y$$

## VECTOR INTEGRATION

### Line Integral

Consider a curve  $C$  in space which consists of infinitesimally small elements of length  $dr$ . Then the line integral of a vector  $\vec{A}(x, y, z)$  along the curve  $C$  is defined to be the sum of the scalar products of  $\vec{A}$ ,  $d\vec{r}$  and is represented by  $\int_C \vec{A} \cdot d\vec{r}$ .

If  $\vec{F}$  is the force acted upon by a particle in displacing it along the curve  $C$  then  $\int_C \vec{F} \cdot d\vec{r}$  represents the total work done by a force, it also represents the circulation of  $\vec{F}$  about  $C$  where  $\vec{F}$  represents the velocity of a fluid.

$\vec{F}$  is said to be irrotational if  $\oint_C \vec{F} \cdot d\vec{r} = 0$ .

### Problems

1. If  $\vec{F} = (5xy - 6x^2)\hat{i} + (2y - 4x)\hat{j}$ , evaluate  $\int_C \vec{F} \cdot d\vec{r}$  where  $C$  is the curve  $y = x^3$  from the point (1,1) to the point (2,8).

**Sol:** Given  $\vec{F} = (5xy - 6x^2)\hat{i} + (2y - 4x)\hat{j}$

$$d\vec{r} = dx\hat{i} + dy\hat{j} + dz\hat{k}$$

Consider,  $\vec{F} \cdot d\vec{r} = [(5xy - 6x^2)\hat{i} + (2y - 4x)\hat{j}] \cdot [dx\hat{i} + dy\hat{j} + dz\hat{k}]$

$$\vec{F} \cdot d\vec{r} = (5xy - 6x^2)dx + (2y - 4x)dy \quad \dots (1)$$

In  $C : y = x^3$                       Points: (1,1) (2,8)

$$dy = 3x^2 dx$$

$$(1) \Rightarrow \vec{F} \cdot d\vec{r} = (5x^4 - 6x^2)dx + (2x^3 - 4x) \cdot 3x^2 dx$$

$$\vec{F} \cdot d\vec{r} = (5x^4 - 6x^2 + 6x^5 - 12x^3)dx$$

$$\int_C \vec{F} \cdot d\vec{r} = \int_1^2 (5x^4 - 6x^2 + 6x^5 - 12x^3)dx$$

$$\int_C \vec{F} \cdot d\vec{r} = 5 \left[ \frac{x^5}{5} \right]_{x=1}^{x=2} - 6 \left[ \frac{x^3}{3} \right]_{x=1}^{x=2} + 6 \left[ \frac{x^6}{6} \right]_{x=1}^{x=2} - 12 \left[ \frac{x^4}{4} \right]_{x=1}^{x=2}$$

$$= (2^5 - 1) - 2(2^3 - 1) + (2^6 - 1) - 3(2^4 - 1)$$

$$= 31 - 14 + 63 - 45$$

$$\int_C \vec{F} \cdot d\vec{r} = 35$$

2. Evaluate  $\int_C \vec{F} \cdot d\vec{r}$  along the circle  $x^2 + y^2 = 4$ , where  $\vec{F} = 3xy\hat{i} - y\hat{j} + 2z\hat{k}$ .

**Sol:** Given  $\vec{F} = 3xy\hat{i} - y\hat{j} + 2z\hat{k}$

$$d\vec{r} = dx\hat{i} + dy\hat{j} + dz\hat{k}$$

Consider,  $\vec{F} \cdot d\vec{r} = [3xy\hat{i} - y\hat{j} + 2z\hat{k}] \cdot [dx\hat{i} + dy\hat{j} + dz\hat{k}]$

$$\vec{F} \cdot d\vec{r} = (3xy)dx + (-y)dy + (2z)dz \quad \dots (1)$$

In  $C : x^2 + y^2 = 4$  ,  $z = 0$

$$x^2 + y^2 = 2^2 \quad (x^2 + y^2 = r^2)$$

Put  $x = r\cos\theta$  ;  $y = r\sin\theta$  ;  $z = 0$

$$x = 2\cos\theta ; y = 2\sin\theta$$

$$dx = -2\sin\theta d\theta ; dy = 2\cos\theta d\theta ; dz = 0$$

$$\theta : \theta = 0 \text{ to } \theta = 2\pi$$

$$(1) \Rightarrow \vec{F} \cdot d\vec{r} = (3 \cdot 2\cos\theta \cdot 2\sin\theta)(-2\sin\theta d\theta) + (-2\sin\theta) \cdot (2\cos\theta d\theta)$$

$$\vec{F} \cdot d\vec{r} = (-24\cos\theta\sin^2\theta - 4\sin\theta\cos\theta)d\theta$$

$$\int_C \vec{F} \cdot d\vec{r} = \int_{\theta=0}^{2\pi} (-24\sin^2\theta\cos\theta - 4\sin\theta\cos\theta)d\theta$$

$$\int_C \vec{F} \cdot d\vec{r} = -24 \left[ \frac{\sin^3 \theta}{3} \right]_0^{2\pi} - 4 \left[ \frac{\sin^2 \theta}{2} \right]_0^{2\pi} \quad \left\{ \int [f(x)]^n f'(x) dx = \frac{[f(x)]^{n+1}}{n+1} \right\}$$

$$\int_C \vec{F} \cdot d\vec{r} = -8(0 - 0) - 2(0 - 0) \quad \{ \sin 2\pi = 0 = \sin 0 \}$$

$$\int_C \vec{F} \cdot d\vec{r} = 0.$$

3. If  $\vec{F} = (3x^2 + 6y)\hat{i} - (14yz)\hat{j} + (20xz^2)\hat{k}$ , evaluate  $\int_C \vec{F} \cdot d\vec{r}$  from the point (0,0,0) to (1,1,1) along the curve given by  $x = t$ ,  $y = t^2$ ,  $z = t^3$ .

**Sol:** Given  $\vec{F} = (3x^2 + 6y)\hat{i} - (14yz)\hat{j} + (20xz^2)\hat{k}$

$$d\vec{r} = dx\hat{i} + dy\hat{j} + dz\hat{k}$$

Consider,  $\vec{F} \cdot d\vec{r} = [(3x^2 + 6y)\hat{i} - (14yz)\hat{j} + (20xz^2)\hat{k}] \cdot [dx\hat{i} + dy\hat{j} + dz\hat{k}]$

$$\vec{F} \cdot d\vec{r} = (3x^2 + 6y)dx + (-14yz)dy + (20xz^2)dz \quad \text{--- (1)}$$

$$\text{In } C : x = t \quad ; \quad y = t^2 \quad ; \quad z = t^3$$

$$dx = dt \quad ; \quad dy = 2tdt \quad ; \quad dz = 3t^2 dt$$

$$t: t = 0 \text{ to } t = 1$$

$$(1) \Rightarrow \vec{F} \cdot d\vec{r} = (3t^2 + 6t^2)dt - (14t^2 t^3) \cdot 2tdt + (20 \cdot t \cdot t^6)3t^2 dt$$

$$\vec{F} \cdot d\vec{r} = (9t^2 - 28t^6 + 60t^9)dt$$

$$\int_C \vec{F} \cdot d\vec{r} = \int_0^1 (9t^2 - 28t^6 + 60t^9)dt$$

$$\int_C \vec{F} \cdot d\vec{r} = 9 \left[ \frac{t^3}{3} \right]_{t=0}^{t=1} - 28 \left[ \frac{t^7}{7} \right]_{t=0}^{t=1} + 60 \left[ \frac{t^{10}}{10} \right]_{t=0}^{t=1}$$

$$= 3(1 - 0) - 4(1 - 0) + 6(1 - 0)$$

$$= 3 - 4 + 6$$

$$\int_C \vec{F} \cdot d\vec{r} = 5$$

4. If  $\vec{F} = (x^2)\hat{i} + (xy)\hat{j}$ , evaluate  $\int_C \vec{F} \cdot d\vec{r}$  from (0,0) to (1,1) along i) the line  $y = x$

ii) the parabola  $y = \sqrt{x}$ .

**Sol:** Given  $\vec{F} = x^2\hat{i} + xy\hat{j}$

$$d\vec{r} = dx\hat{i} + dy\hat{j} + dz\hat{k}$$

Consider,  $\vec{F} \cdot d\vec{r} = [(x^2)\hat{i} + (xy)\hat{j}] \cdot [dx\hat{i} + dy\hat{j} + dz\hat{k}]$

$$\vec{F} \cdot d\vec{r} = (x^2)dx + (xy)dy \quad \text{--- (1)}$$

i) Along  $y = x$

**Point:** (0,0) to (1,1)

$$dy = dx$$

$$(1) \Rightarrow \vec{F} \cdot d\vec{r} = (x^2)dx + (x \cdot x)dx$$

$$\vec{F} \cdot d\vec{r} = (x^2 + x^2)dx$$

$$\vec{F} \cdot d\vec{r} = 2x^2 dx$$

$$\int_c \vec{F} \cdot d\vec{r} = \int_0^1 2x^2 dx$$

$$\int_c \vec{F} \cdot d\vec{r} = 2 \left[ \frac{x^3}{3} \right]_{x=0}^{x=1}$$

$$\int_c \vec{F} \cdot d\vec{r} = \frac{2}{3}(1 - 0)$$

$$\int_c \vec{F} \cdot d\vec{r} = \frac{2}{3}$$

ii) Along  $y = \sqrt{x}$  ;  $y^2 = x$

**Point:** (0,0) to (1,1)

$$2ydy = dx$$

$$(1) \Rightarrow \vec{F} \cdot d\vec{r} = (y^4)2ydy + (y^2 \cdot y)dy$$

$$\vec{F} \cdot d\vec{r} = (2y^5 + y^3)dy$$

$$\int_c \vec{F} \cdot d\vec{r} = \int_0^1 (2y^5 + y^3)dy$$

$$\int_c \vec{F} \cdot d\vec{r} = 2 \left[ \frac{y^6}{6} \right]_{y=0}^{y=1} + \left[ \frac{y^4}{4} \right]_{y=0}^{y=1}$$

$$\int_c \vec{F} \cdot d\vec{r} = \frac{1}{3}(1 - 0) + \frac{1}{4}(1 - 0)$$

$$\int_c \vec{F} \cdot d\vec{r} = \frac{1}{3} + \frac{1}{4}$$

$$\int_C \vec{F} \cdot d\vec{r} = \frac{7}{12}$$

5. Find the total work done by a force  $\vec{F} = 2xy\hat{i} - 4z\hat{j} + 5x\hat{k}$  along the curve  $x = t^2$ ,  $y = (2t+1)$ ,  $z = t^3$  from the point  $t = 1$  to  $t = 2$ .

**Sol:** Given  $\vec{F} = 2xy\hat{i} - 4z\hat{j} + 5x\hat{k}$   
 $d\vec{r} = dx\hat{i} + dy\hat{j} + dz\hat{k}$

Consider,  $\vec{F} \cdot d\vec{r} = [2xy\hat{i} - 4z\hat{j} + 5x\hat{k}] \cdot [dx\hat{i} + dy\hat{j} + dz\hat{k}]$   
 $\vec{F} \cdot d\vec{r} = 2xydx - 4zdy + 5xdz \quad \dots (1)$

In  $C$  :  $x = t^2$ ;  $y = 2t + 1$  ;  $z = t^3$   
 $dx = 2tdt$ ;  $dy = 2dt$  ;  $dz = 3t^2dt$   
 $t: t = 1$  to  $t = 2$

(1)  $\Rightarrow \vec{F} \cdot d\vec{r} = (2t^2(2t + 1))2tdt - 4(t^3) \cdot 2dt + (5t^2)3t^2dt$   
 $\vec{F} \cdot d\vec{r} = (8t^4 + 4t^3 - 8t^3 + 15t^4)dt$   
 $\vec{F} \cdot d\vec{r} = (23t^4 - 4t^3)dt$

The work done by a force =  $\int_C \vec{F} \cdot d\vec{r}$

$$\begin{aligned} \int_C \vec{F} \cdot d\vec{r} &= \int_{t=1}^2 (23t^4 - 4t^3)dt \\ &= 23 \left[ \frac{t^5}{5} \right]_{t=1}^2 - 4 \left[ \frac{t^4}{4} \right]_{t=1}^2 \\ &= \frac{23}{5} (2^5 - 1) - (2^4 - 1) \\ &= \frac{23(31)}{5} - 15 = \frac{713-75}{5} \end{aligned}$$

**Work done**,  $\int_C \vec{F} \cdot d\vec{r} = \frac{638}{5}$  units

6. Find the total work done by a force  $\vec{F} = 3x^2\hat{i} + (2xz - y)\hat{j} + z\hat{k}$  when it moves a particle from the point  $t = 0$  and  $t = 2$  along the curve  $x = t$ ,  $y = \frac{t^2}{4}$ ,  $z = \frac{3t^3}{8}$ .

**Sol:** Given  $\vec{F} = 3x^2\hat{i} + (2xz - y)\hat{j} + z\hat{k}$   
 $d\vec{r} = dx\hat{i} + dy\hat{j} + dz\hat{k}$

Consider,  $\vec{F} \cdot d\vec{r} = [3x^2\hat{i} + (2xz - y)\hat{j} + z\hat{k}] \cdot [dx\hat{i} + dy\hat{j} + dz\hat{k}]$   
 $\vec{F} \cdot d\vec{r} = 3x^2dx + (2xz - y)dy + zdz \quad \dots (1)$

$$\text{In } C : x = t \quad ; \quad y = \frac{t^2}{4} \quad ; \quad z = \frac{3t^3}{8}$$

$$dx = dt \quad ; \quad dy = \frac{2t}{4} dt = \frac{t}{2} dt \quad ; \quad dz = \frac{(3)3t^2}{8} dt = \frac{9t^2}{8} dt$$

$$t: t = 0 \text{ to } t = 2$$

$$(1) \Rightarrow \vec{F} \cdot d\vec{r} = 3t^2 dt + \left[ 2t \left( \frac{3t^3}{8} \right) - \frac{t^2}{4} \right] \frac{t}{2} dt + \frac{3t^3}{8} \cdot \frac{9t^2}{8} dt$$

$$\vec{F} \cdot d\vec{r} = \left( 3t^2 + \frac{3t^5}{8} - \frac{t^3}{8} + \frac{27t^5}{64} \right) dt$$

$$\vec{F} \cdot d\vec{r} = \left( 3t^2 - \frac{t^3}{8} + \frac{51t^5}{64} \right) dt$$

The work done by a force =  $\int_C \vec{F} \cdot d\vec{r}$

$$\begin{aligned} \int_C \vec{F} \cdot d\vec{r} &= \int_{t=0}^2 \left( 3t^2 - \frac{t^3}{8} + \frac{51t^5}{64} \right) dt \\ &= 3 \left[ \frac{t^3}{3} \right]_{t=0}^2 - \frac{1}{8} \left[ \frac{t^4}{4} \right]_{t=0}^2 + \frac{51}{64} \left[ \frac{t^6}{6} \right]_{t=0}^2 \\ &= (2^3 - 0) - \frac{1}{32} (2^4 - 0) + \frac{51}{384} (2^6 - 0) \\ &= 8 - \frac{166}{32} + \frac{51}{384} (64) \end{aligned}$$

$$\int_C \vec{F} \cdot d\vec{r} = 8 - \frac{1}{2} + \frac{51}{6}$$

$$\int_C \vec{F} \cdot d\vec{r} = \frac{48 - 3 + 51}{6}$$

$$\int_C \vec{F} \cdot d\vec{r} = \frac{96}{6}$$

**Work done,  $\int_C \vec{F} \cdot d\vec{r} = 16 \text{ units}$**

### Green's Theorem

Let  $M(x, y)$  and  $N(x, y)$  be two functions defined in region ' $R$ ' and the  $xy - \text{Plane}$  with simple closed curve  $C$  has its boundary, then  $\oint_C \mathbf{M}dx + \mathbf{N}dy = \iint_R \left[ \frac{\partial M}{\partial x} - \frac{\partial N}{\partial y} \right] dydx$

**Note:**

$$1. \text{ Area} = \iint_R dydx = \frac{1}{2} \int_C (xdy - ydx)$$

### Problems

1. Evaluate  $\int_C (xy - x^2)dx + x^2ydy$  where  $C$  is the closed curve bounded by  $y = 0$ ,  $x = 1$  and  $y = x$ .

**Sol:** Green's Theorem:  $\oint_C \mathbf{M}dx + \mathbf{N}dy = \iint_R \left[ \frac{\partial N}{\partial x} - \frac{\partial M}{\partial y} \right] dydx$  --- (1)

Given  $\int_C (xy - x^2)dx + x^2ydy$

Here,  $M = xy - x^2$        $N = x^2y$

$$\frac{\partial M}{\partial y} = x \qquad \frac{\partial N}{\partial x} = 2xy$$

In 'R'

$$x: x = 0 \text{ to } x = 1$$

$$y: y = 0 \text{ to } y = x$$

$$\begin{aligned} (1) \Rightarrow \int_C (xy - x^2)dx + x^2ydy &= \int_{x=0}^1 \int_{y=0}^x (2xy - x)dydx \\ &= \int_{x=0}^1 \left[ 2x \left[ \frac{y^2}{2} \right]_0^x - x[y]_0^x \right] dx \\ &= \int_{x=0}^1 [x(x^2 - 0) - x(x - 0)]dx \end{aligned}$$

$$\begin{aligned} \int_C (xy - x^2)dx + x^2ydy &= \int_{x=0}^1 (x^3 - x^2) dx \\ &= \left[ \frac{x^4}{4} \right]_{x=0}^1 - \left[ \frac{x^3}{3} \right]_{x=0}^1 \\ &= \frac{1}{4} - \frac{1}{3} = \frac{3-4}{12} \end{aligned}$$

$$\int_C (xy - x^2)dx + x^2ydy = \frac{-1}{12}$$

2. Use Green's theorem to evaluate  $\int_C (x^2 + y^2)dx + 3x^2ydy$  where  $C$  is the circle  $x^2 + y^2 = 4$  traced in the positive sign.

**Sol:** Green's Theorem:  $\oint_C \mathbf{M}dx + \mathbf{N}dy = \iint_R \left[ \frac{\partial N}{\partial x} - \frac{\partial M}{\partial y} \right] dydx$  --- (1)

Given  $\int_C (x^2 + y^2)dx + 3x^2ydy$

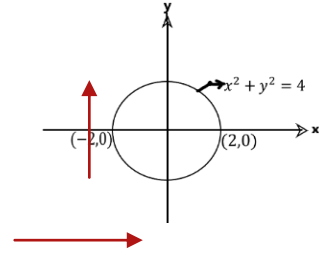

Here,  $M = x^2 + y^2$        $N = 3x^2$

$$\frac{\partial M}{\partial y} = 2y$$

$$\frac{\partial N}{\partial x} = 6xy$$

In 'R'

$$x: x = -2 \text{ to } x = 2$$

$$y: y = -\sqrt{4-x^2} \text{ to } y = \sqrt{4-x^2}$$

$$(1) \Rightarrow \int_C (x^2 + y^2)dx + 3x^2ydy = \int_{x=-2}^2 \int_{y=-\sqrt{4-x^2}}^{\sqrt{4-x^2}} (6xy - 2y)dydx$$

$$= \int_{x=-2}^2 \left[ 6x \left[ \frac{y^2}{2} \right]_{-\sqrt{4-x^2}}^{\sqrt{4-x^2}} - 2 \left[ \frac{y^2}{2} \right]_{-\sqrt{4-x^2}}^{\sqrt{4-x^2}} \right] dx$$

$$= \int_{x=-2}^2 \left[ 3x \left[ \left[ \sqrt{4-x^2} \right]^2 - \left[ -\sqrt{4-x^2} \right]^2 \right] - \left[ \left[ \sqrt{4-x^2} \right]^2 - \left[ -\sqrt{4-x^2} \right]^2 \right] \right] dx$$

$$\int_C (x^2 + y^2)dx + 3x^2ydy = \int_{x=-2}^2 [3x[(4-x^2) - (4-x^2)] - [(4-x^2) - (4-x^2)]]dx$$

$$\int_C (x^2 + y^2)dx + 3x^2ydy = 0.$$

3. Use Green's theorem to find area between the parabola  $x^2 = 4y$  and  $y^2 = 4x$ .

**Sol:** Wkt  $\text{Area} = \iint_R dydx = \frac{1}{2} \int_C (xdy - ydx)$

Thus,  $A = \frac{1}{2} \int_C (xdy - ydx)$

$$A = \frac{1}{2} \left[ \int_{OA} (xdy - ydx) + \int_{AO} (xdy - ydx) \right] \quad \text{--- (1)}$$

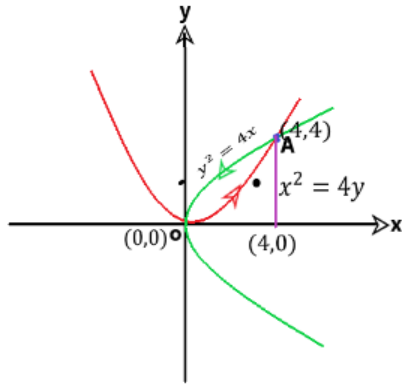

$$\begin{aligned}
 y^2 &= 4x \quad \& \quad x^2 = 4y \\
 y^4 &= 16x^2 \\
 y^4 &= 16(4y) \\
 y^4 &= 64y \\
 y^4 - 64y &= 0 \\
 y(y^3 - 64) &= 0 \\
 y = 0 \quad y^3 &= 64 \\
 y = 0 \quad \& \quad y &= 4
 \end{aligned}$$

Along OA:

$$x^2 = 4y$$

$$y = \frac{x^2}{4}$$

$$dy = \frac{2x}{4} dx$$

$$dy = \frac{x}{2} dx$$

Along AO:

$$y^2 = 4x$$

$$x = \frac{y^2}{4}$$

$$dx = \frac{2y}{4} dy$$

$$dx = \frac{y}{2} dy$$

In 'R'

$$x: x = 0 \text{ to } x = 4y: y = 4 \text{ to } y = 0$$

$$(1) \Rightarrow A = \frac{1}{2} \left[ \int_{x=0}^4 \left( x \cdot \frac{x}{2} dx - \frac{x^2}{4} dx \right) + \int_{y=4}^0 \left( \frac{y^2}{4} dy - y \cdot \frac{y}{2} dy \right) \right]$$

$$A = \frac{1}{2} \left[ \int_{x=0}^4 \left( \frac{x^2}{2} - \frac{x^2}{4} \right) dx + \int_{y=4}^0 \left( \frac{y^2}{4} - \frac{y^2}{2} \right) dy \right]$$

$$A = \frac{1}{2} \left[ \int_{x=0}^4 \left( \frac{x^2}{4} \right) dx - \int_{y=4}^0 \left( \frac{y^2}{4} \right) dy \right]$$

$$A = \frac{1}{2 * 4} \left[ \int_{x=0}^4 x^2 dx - \int_{y=4}^0 y^2 dy \right]$$

$$A = \frac{1}{8} \left[ \left[ \frac{x^3}{3} \right]_0^4 - \left[ \frac{y^3}{3} \right]_4^0 \right]$$

$$A = \frac{1}{8 * 3} [(4^3 - 0) - (0 - 4^3)]$$

$$A = \frac{1}{24} [64 + 64]$$

$$A = \frac{128}{24}$$

$$A = \frac{16}{3} \text{ Sq.Units}$$

### Stoke's Theorem

If  $S$  is a surface bounded by a simple closed curve  $C$  and if  $\vec{F}$  is any continuously differentiable vector function then

$$\oint_C \vec{F} \cdot d\vec{r} = \iint_S \text{curl} \vec{F} \cdot \hat{n} \, ds = \iint_S (\nabla \times \vec{F}) \cdot \hat{n} \, ds$$

### Problems

1. Verify Stoke's theorem for  $\vec{F} = y\hat{i} + z\hat{j} + x\hat{k}$  where  $S$  is the upper half of the sphere  $x^2 + y^2 + z^2 = 1$  and  $C$  is its boundary.

**Sol:** By Stoke's theorem,

$\oint_C \vec{F} \cdot d\vec{r} = \iint_S \text{curl} \vec{F} \cdot \hat{n} \, ds$ ,  $C$  is the circle in the  $xy$  - plane whose centre is the origin and radius equal to unity.

i.e.,  $x^2 + y^2 = 1$  and  $z = 0$

$$dz = 0$$

Put  $x = \cos\theta$   $y = \sin\theta$  ;  $0 \leq \theta \leq 2\pi$

LHS,  $\oint_C \vec{F} \cdot d\vec{r} = \oint_C ydx + zdy + xdz$

$$= \int_{\theta=0}^{2\pi} (\sin\theta)(-\sin\theta d\theta) + (0) + (0)$$

$$= - \int_{\theta=0}^{2\pi} \sin^2\theta d\theta$$

$$= - \int_{\theta=0}^{2\pi} \frac{(1-\cos 2\theta)}{2} d\theta$$

$$= - \frac{1}{2} \int_{\theta=0}^{2\pi} (1 - \cos 2\theta) d\theta$$

$$= - \frac{1}{2} \left\{ [\theta]_0^{2\pi} - \left[ \frac{\sin 2\theta}{2} \right]_0^{2\pi} \right\}$$

$$= - \frac{1}{2} \left\{ [2\pi - 0] - \frac{1}{2} [\sin 4\pi - \sin 0] \right\}$$

$$\oint_C \vec{F} \cdot d\vec{r} = -\frac{1}{2}(2\pi)$$

$$\oint_C \vec{F} \cdot d\vec{r} = -\pi$$

Now,  $\text{curl} \vec{F} = \nabla \times \vec{F}$

$$= \begin{vmatrix} \hat{i} & \hat{j} & \hat{k} \\ \frac{\partial}{\partial x} & \frac{\partial}{\partial y} & \frac{\partial}{\partial z} \\ y & z & x \end{vmatrix}$$

$$= \left[ \frac{\partial}{\partial y}(x) - \frac{\partial}{\partial z}(z) \right] \hat{i} - \left[ \frac{\partial}{\partial x}(x) - \frac{\partial}{\partial z}(y) \right] \hat{j} + \left[ \frac{\partial}{\partial x}(z) - \frac{\partial}{\partial y}(y) \right] \hat{k}$$

$$= [0 - 1]\hat{i} - [1 - 0]\hat{j} + [0 - 1]\hat{k}$$

$$\text{curl}\vec{F} = -\hat{i} - \hat{j} - \hat{k}$$

$$\hat{n}ds = dydz\hat{i} + dx dz\hat{j} + dx dy\hat{k}$$

$$\hat{n}ds = 0.\hat{i} + 0.\hat{j} + dx dy\hat{k} \quad (\text{Since } z = 0, dz = 0)$$

$$\text{curl}\vec{F} \cdot \hat{n}ds = (-\hat{i} - \hat{j} - \hat{k}) \cdot (0.\hat{i} + 0.\hat{j} + dx dy\hat{k})$$

$$\text{curl}\vec{F} \cdot \hat{n}ds = -dx dy$$

$$\text{RHS, } \iint_S \text{curl}\vec{F} \cdot \hat{n} ds = \iint_S -dx dy$$

$$\iint_S \text{curl}\vec{F} \cdot \hat{n} ds = - \iint_S dx dy$$

$$\iint_S \text{curl}\vec{F} \cdot \hat{n} ds = -\pi \quad (\text{Since } \iint_S dx dy = \text{Area of circle, } x^2 + y^2 = 1 = \pi(1)^2 = \pi)$$

**LHS = RHS**

2. Evaluate  $\oint_C (xy dx + xy^2 dy)$  by Stoke's theorem where  $C$  is the square in  $xy$  - plane with

vertices  $(1,0)$   $(-1,0)$   $(0,1)$   $(0,-1)$ .

**Sol:** Given  $\oint_C (xy dx + xy^2 dy)$

$$\oint_C \vec{F} \cdot d\vec{r} = \oint_C (xy dx + xy^2 dy)$$

**Here,**  $\vec{F} = xy\hat{i} + xy^2\hat{j} + 0\hat{k}$

Now,  $\text{curl}\vec{F} = \nabla \times \vec{F}$

$$= \begin{vmatrix} \hat{i} & \hat{j} & \hat{k} \\ \frac{\partial}{\partial x} & \frac{\partial}{\partial y} & \frac{\partial}{\partial z} \\ xy & xy^2 & 0 \end{vmatrix}$$

$$= \left[ \frac{\partial}{\partial y}(0) - \frac{\partial}{\partial z}(xy^2) \right] \hat{i} - \left[ \frac{\partial}{\partial x}(0) - \frac{\partial}{\partial z}(xy) \right] \hat{j} + \left[ \frac{\partial}{\partial x}(xy^2) - \frac{\partial}{\partial y}(xy) \right] \hat{k}$$

$$\text{curl}\vec{F} = [0 - 0]\hat{i} - [0 - 0]\hat{j} + [y^2 - x]\hat{k}$$

$$\hat{n}ds = dydz\hat{i} + dx dz\hat{j} + dx dy\hat{k}$$

$$\text{curl}\vec{F} \cdot \hat{n}ds = (0.\hat{i} - 0.\hat{j} + [y^2 - x]\hat{k}) \cdot (dydz\hat{i} + dx dz\hat{j} + dx dy\hat{k})$$

$$\text{curl}\vec{F} \cdot \hat{n}ds = [y^2 - x]dx dy$$

$$\text{Wkt, } \oint_C \vec{F} \cdot d\vec{r} = \iint_R \text{curl}\vec{F} \cdot \hat{n} ds$$

$$= \iint_R [y^2 - x]dx dy$$

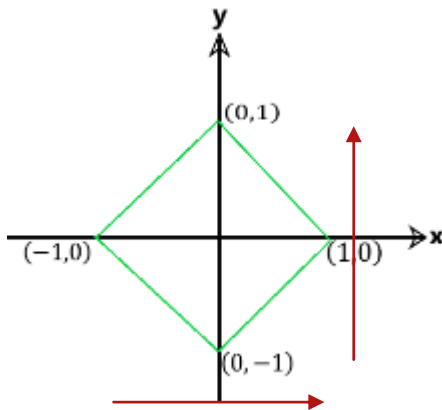

In 'R'

$x: x = -1$  to  $x = 1$

$y: y = -1$  to  $y = 1$

$$\oint_C \vec{F} \cdot d\vec{r} = \int_{x=-1}^1 \int_{y=-1}^1 [y^2 - x]dy dx$$

$$= \int_{x=-1}^1 \left\{ \left[ \frac{y^3}{3} \right]_{-1}^1 - x[y]_{-1}^1 \right\} dx$$

$$= \int_{x=-1}^1 \left[ \frac{1}{3}[1 - (-1)] - x[1 - (-1)] \right] dx$$

$$\oint_C \vec{F} \cdot d\vec{r} = \int_{x=-1}^1 \left[ \frac{2}{3} - 2x \right] dx$$

$$\oint_C \vec{F} \cdot d\vec{r} = \frac{2}{3}[x]_{-1}^1 - 2 \left[ \frac{x^2}{2} \right]_{-1}^1$$

$$\oint_C \vec{F} \cdot d\vec{r} = \frac{2}{3}[1 - (-1)] - [(1)^2 - (-1)^2]$$

$$\oint_C \vec{F} \cdot d\vec{r} = \frac{2}{3}[2] - [0]$$

$$\oint_C \vec{F} \cdot d\vec{r} = \frac{4}{3}$$

3. Evaluate  $\oint_C (x^2 + y^2)dx - 2xydy$  taken round the rectangle bounded by  $x = 0, x = a, y = 0, y = b$  using Stoke's theorem .

**Sol:** Given  $\oint_C (x^2 + y^2)dx - 2xydy$

$$\oint_C \vec{F} \cdot d\vec{r} = \oint_C (x^2 + y^2)dx - 2xydy$$

**Here,**  $\vec{F} = (x^2 + y^2)\hat{i} - 2xy\hat{j} + 0\hat{k}$

Now,  $\text{curl}\vec{F} = \nabla \times \vec{F}$

$$= \begin{vmatrix} \hat{i} & \hat{j} & \hat{k} \\ \frac{\partial}{\partial x} & \frac{\partial}{\partial y} & \frac{\partial}{\partial z} \\ (x^2 + y^2) & -2xy & 0 \end{vmatrix}$$

$$= \left[ \frac{\partial}{\partial y}(0) - \frac{\partial}{\partial z}(-2xy) \right] \hat{i} - \left[ \frac{\partial}{\partial x}(0) - \frac{\partial}{\partial z}((x^2 + y^2)) \right] \hat{j} + \left[ \frac{\partial}{\partial x}(-2xy) - \frac{\partial}{\partial y}((x^2 + y^2)) \right] \hat{k}$$

$$\text{curl}\vec{F} = [0 - 0]\hat{i} - [0 - 0]\hat{j} + [-2y - 2y]\hat{k}$$

$$\text{curl}\vec{F} = 0\hat{i} - 0\hat{j} - 4y\hat{k}$$

$$\hat{n}ds = dydz\hat{i} + dxdz\hat{j} + dxdy\hat{k}$$

$$\text{curl}\vec{F} \cdot \hat{n}ds = (0\hat{i} - 0\hat{j} - 4y\hat{k}) \cdot (dydz\hat{i} + dxdz\hat{j} + dxdy\hat{k})$$

$$\text{curl}\vec{F} \cdot \hat{n}ds = -4ydx dy$$

Wkt,  $\oint_C \vec{F} \cdot d\vec{r} = \iint_R \text{curl}\vec{F} \cdot \hat{n} ds$

$$= \iint_R -4ydx dy$$

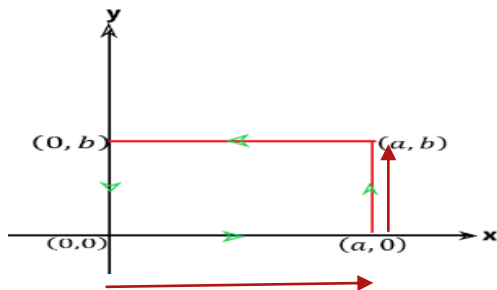

In 'R'

$x: x = 0 \text{ to } x = a$

$y: y = 0 \text{ to } y = b$

$$\begin{aligned}
\oint_C \vec{F} \cdot d\vec{r} &= -4 \int_{x=0}^a \int_{y=0}^b y \, dy \, dx \\
&= -4 \int_{x=0}^a \left\{ \left[ \frac{y^2}{2} \right]_0^b \right\} dx \\
&= -4 \int_{x=0}^a \left\{ \left[ \frac{b^2}{2} - 0 \right] \right\} dx \\
\oint_C \vec{F} \cdot d\vec{r} &= -4 \cdot \frac{b^2}{2} \int_{x=0}^a 1 \, dx \\
\oint_C \vec{F} \cdot d\vec{r} &= -2b^2 [x]_0^a \\
\oint_C \vec{F} \cdot d\vec{r} &= -2b^2 (a - 0) \\
\oint_C \vec{F} \cdot d\vec{r} &= -2ab^2
\end{aligned}$$

4. Using Stoke's theorem to evaluate  $\oint_C \vec{F} \cdot d\vec{r}$  where  $\vec{F} = y\hat{i} + z\hat{j} + x\hat{k}$  and  $C$  is the boundary of the upper half of the sphere  $x^2 + y^2 + z^2 = 1$ .

**Sol:** Given  $\vec{F} = y\hat{i} + z\hat{j} + x\hat{k}$

$C$  is the circle in the  $xy$  - plane whose centre is the origin and radius equal to unity.

i.e.,  $x^2 + y^2 = 1$  and  $z = 0$   
 $dz = 0$

Now,  $\text{curl}\vec{F} = \nabla \times \vec{F}$

$$\begin{aligned}
&= \begin{vmatrix} \hat{i} & \hat{j} & \hat{k} \\ \frac{\partial}{\partial x} & \frac{\partial}{\partial y} & \frac{\partial}{\partial z} \\ y & z & x \end{vmatrix} \\
&= \left[ \frac{\partial}{\partial y}(x) - \frac{\partial}{\partial z}(z) \right] \hat{i} - \left[ \frac{\partial}{\partial x}(x) - \frac{\partial}{\partial z}(y) \right] \hat{j} + \left[ \frac{\partial}{\partial x}(z) - \frac{\partial}{\partial y}(y) \right] \hat{k} \\
&= [0 - 1]\hat{i} - [1 - 0]\hat{j} + [0 - 1]\hat{k}
\end{aligned}$$

$$\text{curl}\vec{F} = -\hat{i} - \hat{j} - \hat{k}$$

$$\hat{n}ds = dydz\hat{i} + dxdz\hat{j} + dxdy\hat{k}$$

$$\hat{n}ds = 0.\hat{i} + 0.\hat{j} + dxdy\hat{k} \quad (\text{Since } z = 0, dz = 0)$$

$$\text{curl}\vec{F} \cdot \hat{n}ds = (-\hat{i} - \hat{j} - \hat{k}) \cdot (0.\hat{i} + 0.\hat{j} + dxdy\hat{k})$$

$$\text{curl} \vec{F} \cdot \hat{n} ds = -dxdy$$

By Stoke's theorem,

$$\oint_C \vec{F} \cdot d\vec{r} = \iint_S \text{curl} \vec{F} \cdot \hat{n} ds$$

$$\oint_C \vec{F} \cdot d\vec{r} = \iint_S -dxdy$$

$$\oint_C \vec{F} \cdot d\vec{r} = - \iint_S dxdy$$

$$\oint_C \vec{F} \cdot d\vec{r} = -\pi \quad \left( \text{Since } \iint_S dxdy = \text{Area of circle, } x^2 + y^2 = 1 = \pi(1)^2 = \pi \right)$$

**Problem on flux**

If  $\vec{F} = 2xy\hat{i} + yz^2\hat{j} + xz\hat{k}$  and  $S$  is the rectangular parallelepiped bounded by  $x = 0, y = 0, z = 0, x = 2, y = 1, z = 3$ . Find the flux across  $S$ .

**Sol:** Here  $\vec{F} = 2xy\hat{i} + yz^2\hat{j} + xz\hat{k}$

Now,  $\text{div} \vec{F} = \nabla \cdot \vec{F}$

$$= \left[ \frac{\partial}{\partial x} \hat{i} + \frac{\partial}{\partial y} \hat{j} + \frac{\partial}{\partial z} \hat{k} \right] \cdot [2xy\hat{i} + yz^2\hat{j} + xz\hat{k}]$$

$$\text{div} \vec{F} = \frac{\partial}{\partial x} (2xy) + \frac{\partial}{\partial y} (yz^2) + \frac{\partial}{\partial z} (xz)$$

$$\text{div} \vec{F} = 2y + z^2 + x$$

$$\text{Flux across } S = \iint_S \vec{F} \cdot \hat{n} ds$$

By divergence theorem,  $\iint_S \vec{F} \cdot \hat{n} ds = \iiint_V \text{div} \vec{F} dv$

$$\iint_S \vec{F} \cdot \hat{n} ds = \int_{z=0}^3 \int_{y=0}^1 \int_{x=0}^2 (2y + z^2 + x) dx dy dz$$

$$= \int_{z=0}^3 \int_{y=0}^1 \left[ (2y + z^2) [x]_0^2 + \left[ \frac{y^2}{2} \right]_0^2 \right] dy dz$$

$$= \int_{z=0}^3 \int_{y=0}^1 (4y + 2z^2 + 2) dy dz$$

$$= \int_{z=0}^3 \left\{ 4 \left[ \frac{y^2}{2} \right]_0^1 + (2z^2 + 2)[y]_0^1 \right\} dz$$

$$= \int_{z=0}^3 \{ 2 + 2z^2 + 2 \} dz$$

$$= \int_{z=0}^3 \{2z^2 + 4\} dz$$

$$\begin{aligned} \iint_S \vec{F} \cdot \hat{n} \, ds &= 2 \left[ \frac{z^3}{3} \right]_0^3 + 4[z]_0^3 \\ &= 2(9 - 0) + 4(3 - 0) \end{aligned}$$

$$\iint_S \vec{F} \cdot \hat{n} \, ds = \mathbf{30}$$

## MODULE-3

### PARTIAL DIFFERENTIAL EQUATIONS

#### Definition

An equation involving one or more partial derivatives of a function of two or more variables is called a **Partial differential equation[PDE]**.

The *order* of a PDE is the order of the highest derivative and the *degree* of highest order derivative after clearing the equation of fractional powers.

A PDE is said to be linear if it is of first degree in the dependent variable and its partial derivatives.

If each term of the PDE contains either the dependent variable or one of its partial derivatives, the PDE is said to be **homogeneous**. Otherwise it is said to be a **nonhomogeneous** PDE.

#### Examples

1.  $\frac{\partial z}{\partial x} + \frac{\partial z}{\partial y} = 0$  [Order – 1, Degree – 1, Homogeneous PDE]

2.  $\frac{\partial^2 z}{\partial x \partial y} = xy$  [Order – 2, Degree – 1, NonHomogeneous PDE]

3.  $\frac{\partial^2 z}{\partial x^2} = \frac{\partial z}{\partial y} + 2z$  [Order – 2, Degree – 1, Homogeneous PDE]

4.  $\frac{\partial^2 z}{\partial x^2} + \frac{\partial^2 z}{\partial y^2} = 0$  [Order – 2, Degree – 1, Homogeneous PDE]

5.  $\frac{\partial^3 z}{\partial x^2 \partial y} = \cos(2x + 3y)$  [Order – 3, Degree – 1, NonHomogeneous PDE]

6.  $\frac{\partial^2 u}{\partial x^2} = x + y$  [Order – 2, Degree – 1, NonHomogeneous PDE]

7.  $\frac{\partial^2 z}{\partial x^2} - 16z = 0$  [Order – 2, Degree – 1, Homogeneous PDE]

8.  $\frac{\partial^2 u}{\partial x \partial y} + 4 \frac{\partial u}{\partial y} = 0$  [Order – 2, Degree – 1, NonHomogeneous PDE]

#### Formation of PDE by eliminating arbitrary constants and arbitrary functions

##### Note:

If  $z = f(x, y)$  , then

$$z_x = \frac{\partial z}{\partial x} = p$$

$$z_y = \frac{\partial z}{\partial y} = q$$

$$z_{xx} = \frac{\partial^2 z}{\partial x^2} = r$$

$$z_{xy} = \frac{\partial^2 z}{\partial x \partial y} = s$$

$$z_{yy} = \frac{\partial^2 z}{\partial y^2} = t$$

### Problems

Form the PDE by eliminating the arbitrary constant in the following

1.  $z = (x + a)(y + b)$

**Sol:** Given  $z = (x + a)(y + b)$  --- (1)

Differentiate (1) w.r.t 'x' and 'y' partially

$$\frac{\partial z}{\partial x} = (y + b).1 \quad \Rightarrow \quad p = (y + b)$$

$$\text{Also, } \frac{\partial z}{\partial y} = (x + a).1 \quad \Rightarrow \quad q = (x + a)$$

$$(1) \Rightarrow z = q.p$$

$z = pq$  , is the required PDE

2.  $2z = \frac{x^2}{a^2} + \frac{y^2}{b^2}$

**Sol:** Given  $2z = \frac{x^2}{a^2} + \frac{y^2}{b^2}$  --- (1)

Differentiate (1) w.r.t 'x' and 'y' partially

$$2 \frac{\partial z}{\partial x} = \frac{2x}{a^2}$$

$$\Rightarrow p = \frac{x}{a^2}$$

Multiply by 'x'

$$px = \frac{x^2}{a^2}$$

$$\text{Also, } 2 \frac{\partial z}{\partial y} = \frac{2y}{b^2}$$

$$\Rightarrow q = \frac{y}{b^2}$$

Multiply by 'y'

$$qy = \frac{y^2}{b^2}$$

(1)  $\Rightarrow 2z = px + qy$ , is the required PDE.

3.  $ax^2 + by^2 + z^2 = 1$

**Sol:** Given  $ax^2 + by^2 + z^2 = 1$

$$z^2 = 1 - ax^2 - by^2 \quad \dots (1)$$

Differentiate (1) w.r.t 'x' and 'y' partially

$$2z \frac{\partial z}{\partial x} = 0 - 2ax - 0$$

$$\Rightarrow 2zp = -2ax$$

$$ax = -zp$$

Multiply by 'x'

$$ax^2 = -zpx$$

**Also,**  $2z \frac{\partial z}{\partial y} = 0 - 0 - 2by$

$$\Rightarrow 2zq = -2by$$

$$by = -zq$$

Multiply by 'y'

$$by^2 = -zqy$$

$$(1) \Rightarrow z^2 = 1 - (-zpx) - (-zqy)$$

$$z^2 - 1 = zpx + zqy$$

$$z^2 - 1 = z(px + qy), \text{ is the required PDE.}$$

$$4. z = a \log(x^2 + y^2) + b$$

**Sol:** Given  $z = a \log(x^2 + y^2) + b \quad \dots (1)$

Differentiate (1) w.r.t 'x' and 'y' partially

$$\frac{\partial z}{\partial x} = a \cdot \frac{1}{(x^2+y^2)} \cdot 2x$$

$$\Rightarrow p = \frac{2xa}{(x^2+y^2)}$$

$$\Rightarrow \frac{p}{x} = \frac{2a}{(x^2+y^2)} \quad \dots (2)$$

Also,  $\frac{\partial z}{\partial y} = a \cdot \frac{1}{(x^2+y^2)} \cdot 2y$

$$\Rightarrow \frac{q}{y} = \frac{2a}{(x^2+y^2)} \quad \dots (3)$$

From (2) and (3), we get

$$\frac{p}{x} = \frac{q}{y}$$

$$py = qx$$

$py - qx = 0$ , is the required PDE.

$$5. z = xy + y\sqrt{x^2 - a^2} + b$$

**Sol:** Given  $z = xy + y\sqrt{x^2 - a^2} + b$  --- (1)

Differentiate (1) w.r.t 'x' and 'y' partially

$$\frac{\partial z}{\partial x} = y + y \frac{1}{2\sqrt{x^2 - a^2}} \cdot 2x$$

$$\Rightarrow p = y + \frac{xy}{\sqrt{x^2 - a^2}}$$

$$\Rightarrow p - y = \frac{xy}{\sqrt{x^2 - a^2}} \quad \text{--- (2)}$$

Also,  $\frac{\partial z}{\partial y} = x \cdot 1 + \sqrt{x^2 - a^2} \cdot 1$

$$q - x = \sqrt{x^2 - a^2} \quad \text{--- (3)}$$

Using (3) in (2), we get

$$(2) \Rightarrow p - y = \frac{xy}{(q-x)}$$

$$(p - y)(q - x) = xy$$

$$pq - px - qy + xy = xy$$

$pq = px + qy$ , is the required PDE.

6. Find the PDE of the family of spheres whose centre lie on the plane  $z = 0$  and have a constant radius 'r'.

**Sol:** The co-ordinates of the centre of the sphere can be taken as  $(a, b, 0)$  where  $a$  and  $b$  are arbitrary.  $r$  is the constant radius.

The equation of the sphere is given by

$$(x - a)^2 + (y - b)^2 + (z - 0)^2 = r^2$$

$$(x - a)^2 + (y - b)^2 + z^2 = r^2$$

$$z^2 = r^2 - (x - a)^2 - (y - b)^2 \quad \text{--- (1)}$$

Differentiate (1) w.r.t 'x' and 'y' partially

$$2z \frac{\partial z}{\partial x} = 0 - 2(x - a) - 0$$

$$\Rightarrow 2zp = -2(x - a)$$

$$\Rightarrow (x - a) = -zp$$

$$\text{Also } 2z \frac{\partial z}{\partial y} = 0 - 0 - 2(y - b)$$

$$\Rightarrow 2zq = -2(y - b)$$

$$\Rightarrow (y - b) = -zq$$

$$(1) \Rightarrow z^2 = r^2 - (-zp)^2 - (-zq)^2$$

$$z^2 = r^2 - z^2 p^2 - z^2 q^2$$

$$z^2 + z^2 p^2 + z^2 q^2 = r^2$$

$$z^2(1 + p^2 + q^2) = r^2, \text{ is the required PDE.}$$

$$7. \frac{x^2}{a^2} + \frac{y^2}{b^2} + \frac{z^2}{c^2} = 1$$

$$\text{Sol: Given } \frac{x^2}{a^2} + \frac{y^2}{b^2} + \frac{z^2}{c^2} = 1$$

$$\frac{z^2}{c^2} = 1 - \frac{x^2}{a^2} - \frac{y^2}{b^2} \quad \text{--- (1)}$$

Differentiate (1) w.r.t 'x' and 'y' partially

$$\frac{2z}{c^2} \frac{\partial z}{\partial x} = 0 - \frac{2x}{a^2} - 0$$

$$\frac{2z}{c^2} p = -\frac{2x}{a^2}$$

$$\frac{zp}{c^2} = -\frac{x}{a^2} \quad \text{--- (2)}$$

$$\text{Also, } \frac{2z}{c^2} \frac{\partial z}{\partial y} = 0 - 0 - \frac{2y}{b^2}$$

$$\frac{2z}{c^2} q = -\frac{2y}{b^2}$$

$$\frac{zq}{c^2} = -\frac{y}{b^2} \quad \text{--- (3)}$$

Differentiate (2) w.r.t 'x' partially

$$\frac{1}{c^2} \frac{\partial}{\partial x} \left[ z \cdot \frac{\partial z}{\partial x} \right] = -\frac{1}{a^2} \frac{\partial}{\partial x} [x]$$

$$\text{Since } p = \frac{\partial z}{\partial x}$$

$$\frac{1}{c^2} \left[ \frac{\partial z}{\partial x} \cdot \frac{\partial z}{\partial x} + z \cdot \frac{\partial^2 z}{\partial x^2} \right] = -\frac{1}{a^2} \cdot 1$$

$$\frac{1}{c^2} [p^2 + z \cdot r] = -\frac{1}{a^2}$$

Multiply by 'x'

$$\frac{x}{c^2} [p^2 + zr] = -\frac{x}{a^2}$$

$$\frac{x}{c^2} [p^2 + zr] = \frac{zp}{c^2} \quad \text{From (2)}$$

$$x[p^2 + zr] = zp$$

$$xp^2 + xzr = zp$$

$$xp^2 + xzr - zp = 0$$

$xp^2 + z(xr - p) = 0$ , is the required PDE.

**8. Form the PDE of the family of spheres whose centre lies on  $x$  - axis with constant radius 3.**

**Sol:** Equation of sphere with centre on  $x$  - axis i.e.,  $C = (a, 0, 0)$  and radius  $r = 3$ .

The equation of the sphere is given by

$$(x - a)^2 + (y - 0)^2 + (z - 0)^2 = 3^2$$

$$(x - a)^2 + y^2 + z^2 = 9$$

$$z^2 = 9 - (x - a)^2 - y^2 \quad \dots (1)$$

Differentiate (1) w.r.t 'x' and 'y' partially

$$2z \frac{\partial z}{\partial x} = 0 - 2(x - a) - 0$$

$$\Rightarrow 2zp = -2(x - a)$$

$$\Rightarrow (x - a) = -zp$$

Also  $2z \frac{\partial z}{\partial y} = 0 - 0 - 2(y - b)$

$$\Rightarrow 2zq = -2(y - b)$$

$$\Rightarrow (y - b) = -zq$$

$$(1) \Rightarrow z^2 = 9 - (-zp)^2 - (-zq)^2$$

$$z^2 = 9 - z^2p^2 - z^2q^2$$

$$z^2 + z^2p^2 + z^2q^2 = 9$$

$$z^2(1 + p^2 + q^2) = 9, \text{ is the required PDE.}$$

**Form the PDE by eliminating arbitrary functions in the following**

**1.  $z = f(x^2 + y^2)$**

**Sol:** Given  $z = f(x^2 + y^2)$  --- (1)

Differentiating (1) partially w.r.t 'x' and 'y', we have

$$\frac{\partial z}{\partial x} = p = f'(x^2 + y^2). 2x$$

$$\frac{\partial z}{\partial y} = q = f'(x^2 + y^2). 2y$$

$$\frac{p}{x} = 2f'(x^2 + y^2) \quad \text{--- (2)}$$

$$\frac{q}{y} = 2f'(x^2 + y^2) \quad \text{--- (3)}$$

From (2) and (3), we have

$$\frac{p}{x} = \frac{q}{y}$$

$$py = qx$$

$py - qx = 0$ , is the required PDE.

$$2. \quad z = y^2 + 2f\left(\frac{1}{x} + \log y\right)$$

$$\text{Sol: Given } z = y^2 + 2f\left(\frac{1}{x} + \log y\right) \quad \text{--- (1)}$$

Differentiating (1) partially w.r.t 'x' and 'y', we have

$$\frac{\partial z}{\partial x} = p = 0 + 2f'\left(\frac{1}{x} + \log y\right) \cdot \left(\frac{-1}{x^2}\right) \quad \frac{\partial z}{\partial y} = q = 2y + 2f'\left(\frac{1}{x} + \log y\right) \cdot \left(\frac{1}{y}\right)$$

$$p = \frac{-1}{x^2} \cdot 2f'\left(\frac{1}{x} + \log y\right) \quad q - 2y = \frac{1}{y} \cdot 2f'\left(\frac{1}{x} + \log y\right)$$

$$x^2p = -2f'\left(\frac{1}{x} + \log y\right) \quad \text{--- (2)} \quad (q - 2y)y = 2f'\left(\frac{1}{x} + \log y\right) \quad \text{--- (3)}$$

From (2) and (3), we have

$$x^2p = -(q - 2y)y$$

$$x^2p = -qy + 2y^2$$

$x^2p + qy = 2y^2$ , is the required PDE.

$$3. \quad z = e^y f(x + y)$$

$$\text{Sol: Given } z = e^y f(x + y) \quad \text{--- (1)}$$

Differentiating (1) partially w.r.t 'x' and 'y', we have

$$\frac{\partial z}{\partial x} = p = e^y f'(x + y) \quad \frac{\partial z}{\partial y} = q = e^y \cdot f'(x + y) + f(x + y) \cdot e^y$$

$$p = e^y f'(x + y) \quad \text{--- (2)} \quad q = e^y \cdot f'(x + y) + z$$

$$q - z = e^y \cdot f'(x + y) \quad \text{--- (3)}$$

From (2) and (3), we have

$$p = q - z$$

$p + z = q$ , is the required PDE.

$$3. \quad z = e^{ax+by} f(ax - by)$$

$$\text{Sol: Given } z = e^{ax+by} f(ax - by) \quad \text{--- (1)}$$

Differentiating (1) partially w.r.t 'x', we have

$$\frac{\partial z}{\partial x} = e^{ax+by} f'(ax - by).a + f(ax - by).e^{ax+by}.a$$

$$p = e^{ax+by} f'(ax - by).a + az$$

$$p - az = ae^{ax+by} f'(ax - by)$$

Multiply by 'b'

$$pb - abz = abe^{ax+by} f'(ax - by) \quad \dots (2)$$

Differentiating (1) partially w.r.t 'y', we have

$$\frac{\partial z}{\partial y} = e^{ax+by} f'(ax - by).(-b) + f(ax - by).e^{ax+by}.b$$

$$q = -be^{ax+by} f'(ax - by) + bz$$

$$q - bz = -be^{ax+by} f'(ax - by)$$

Multiply by 'a'

$$qa - abz = -abe^{ax+by} f'(ax - by) \quad \dots (3)$$

From (2) and (3), we get

$$pb - abz = -(qa - abz)$$

$$pb - abz = -qa + abz$$

$$pb + qa = abz + abz$$

**$pb + qa = 2abz$** , is the required PDE.

#### 4. $z = e^{ax+by} f(ax - by)$

**Sol:** Given  $z = e^{ax+by} f(ax - by) \quad \dots (1)$

Differentiating (1) partially w.r.t 'x', we have

$$\frac{\partial z}{\partial x} = e^{ax+by} f'(ax - by).a + f(ax - by).e^{ax+by}.a$$

$$p = e^{ax+by} f'(ax - by).a + az$$

$$p - az = ae^{ax+by} f'(ax - by)$$

Multiply by 'b'

$$pb - abz = abe^{ax+by} f'(ax - by) \quad \dots (2)$$

Differentiating (1) partially w.r.t 'y', we have

$$\frac{\partial z}{\partial y} = e^{ax+by} f'(ax - by).(-b) + f(ax - by).e^{ax+by}.b$$

$$q = -be^{ax+by} f'(ax - by) + bz$$

$$q - bz = -be^{ax+by} f'(ax - by)$$

Multiply by 'a'

$$qa - abz = -abe^{ax+by} f'(ax - by) \quad \dots (3)$$

From (2) and (3), we get

$$pb - abz = -(qa - abz)$$

$$pb - abz = -qa + abz$$

$$pb + qa = abz + abz$$

$pb + qa = 2abz$ , is the required PDE.

$$5. lx + my + nz = \varphi(x^2 + y^2 + z^2)$$

**Sol:** Given  $lx + my + nz = \varphi(x^2 + y^2 + z^2)$  --- (1)

Differentiating (1) partially w.r.t 'x', we have

$$l.1 + 0 + n \frac{\partial z}{\partial x} = \varphi'(x^2 + y^2 + z^2). (2x + 0 + 2z \frac{\partial z}{\partial x})$$

$$l + np = 2\varphi'(x^2 + y^2 + z^2). (x + zp)$$

$$\frac{(l+np)}{(x+zp)} = 2\varphi'(x^2 + y^2 + z^2) \quad \text{--- (2)}$$

Differentiating (1) partially w.r.t 'y', we have

$$0 + m.1 + n \frac{\partial z}{\partial y} = \varphi'(x^2 + y^2 + z^2). (0 + 2y + 2z \frac{\partial z}{\partial y})$$

$$m + nq = 2\varphi'(x^2 + y^2 + z^2). (y + zq)$$

$$\frac{(m+nq)}{(y+zq)} = 2\varphi'(x^2 + y^2 + z^2) \quad \text{--- (3)}$$

From (2) and (3), we get

$$\frac{(l+np)}{(x+zp)} = \frac{(m+nq)}{(y+zq)}$$

$$(l + np)(y + zq) = (x + zp)(m + nq)$$

$$ly + lzq + npy + npzq = mx + nqx + mzp + zpnq$$

$$ly - mx = nqx + mzp - lzq - npy$$

$ly - mx = p(mz - ny) + q(nx - lz)$ , is the required PDE.

$$6. \varphi(x + y + z, x^2 + y^2 - z^2) = 0$$

**Sol:** Given  $\varphi(x + y + z, x^2 + y^2 - z^2) = 0$

Let  $u = x + y + z$

$$v = x^2 + y^2 - z^2$$

$$\frac{\partial u}{\partial x} = 1 + 0 + \frac{\partial z}{\partial x}$$

$$\frac{\partial v}{\partial x} = 2x + 0 - 2z \frac{\partial z}{\partial x}$$

$$\frac{\partial u}{\partial x} = 1 + p$$

$$\frac{\partial v}{\partial x} = 2x - 2zp$$

$$\frac{\partial u}{\partial y} = 0 + 1 + \frac{\partial z}{\partial y}$$

$$\frac{\partial v}{\partial y} = 0 + 2y - 2z \frac{\partial z}{\partial y}$$

$$\frac{\partial u}{\partial y} = 1 + q$$

$$\frac{\partial v}{\partial y} = 2y - 2zq$$

$$\text{Now } \varphi(u, v) = \begin{vmatrix} \frac{\partial u}{\partial x} & \frac{\partial u}{\partial y} \\ \frac{\partial v}{\partial x} & \frac{\partial v}{\partial y} \end{vmatrix}$$

$$\varphi(u, v) = 0$$

$$\begin{vmatrix} (1+p) & (1+q) \\ (2x-2zp) & (2y-2zq) \end{vmatrix} = 0$$

$$(1+p)(2y-2zq) - (1+q)(2x-2zp) = 0$$

$$2y - 2zq + 2py - 2zpq - 2x + 2zp - 2qx + 2zpq = 0 \quad \div \text{ by } 2$$

$$y - zq + py - x + zp - qx = 0$$

$$-zq + py + zp - qx = x - y$$

$p(y+z) - q(x+z) = x - y$ , is the required PDE.

$$7. \varphi(xy + z^2, x + y + z) = 0$$

**Sol:** Given  $\varphi(xy + z^2, x + y + z) = 0$

$$\text{Let } u = xy + z^2$$

$$v = x + y + z$$

$$\frac{\partial u}{\partial x} = y \cdot 1 + 2z \frac{\partial z}{\partial x}$$

$$\frac{\partial v}{\partial x} = 1 + 0 + \frac{\partial z}{\partial x}$$

$$\frac{\partial u}{\partial x} = y + 2zp$$

$$\frac{\partial v}{\partial x} = 1 + p$$

$$\frac{\partial u}{\partial y} = x \cdot 1 + 0 + 2z \frac{\partial z}{\partial y}$$

$$\frac{\partial v}{\partial y} = 1 + 0 + \frac{\partial z}{\partial y}$$

$$\frac{\partial u}{\partial y} = x + 2zq$$

$$\frac{\partial v}{\partial y} = 1 + q$$

$$\text{Now } \varphi(u, v) = \begin{vmatrix} \frac{\partial u}{\partial x} & \frac{\partial u}{\partial y} \\ \frac{\partial v}{\partial x} & \frac{\partial v}{\partial y} \end{vmatrix}$$

$$\varphi(u, v) = 0$$

$$\begin{vmatrix} (y+2zp) & (x+2zq) \\ (1+p) & (1+q) \end{vmatrix} = 0$$

$$(y+2zp)(1+q) - (x+2zq)(1+p) = 0$$

$$y + yq + 2zp + 2zpq - x - 2zq - px - 2pzq = 0$$

$$y + yq + 2zp - x - 2zq - px = 0$$

$$yq + 2zp - 2zq - px = x - y$$

$p(2z - x) + q(y - 2z) = x - y$ , is the required PDE.

$$8. f(x^2 + y^2, z - xy) = 0$$

**Sol:** Given  $f(x^2 + y^2, z - xy) = 0$

Let  $u = x^2 + y^2$

$v = z - xy$

$$\frac{\partial u}{\partial x} = 2x + 0$$

$$\frac{\partial v}{\partial x} = \frac{\partial z}{\partial x} - y. 1$$

$$\frac{\partial u}{\partial x} = 2x$$

$$\frac{\partial v}{\partial x} = p - y$$

$$\frac{\partial u}{\partial y} = 0 + 2y$$

$$\frac{\partial v}{\partial y} = \frac{\partial z}{\partial y} - x. 1$$

$$\frac{\partial u}{\partial y} = 2y$$

$$\frac{\partial v}{\partial y} = q - x$$

Now  $f(u, v) = \begin{vmatrix} \frac{\partial u}{\partial x} & \frac{\partial u}{\partial y} \\ \frac{\partial v}{\partial x} & \frac{\partial v}{\partial y} \end{vmatrix}$

$$f(u, v) = 0$$

$$\begin{vmatrix} (2x) & (2y) \\ (p - y) & (q - x) \end{vmatrix} = 0$$

$$(2x)(q - x) - (2y)(p - y) = 0$$

$$2xq - 2x^2 - 2yp + 2y^2 = 0 \quad \div \text{ by } 2$$

$xq - yp = x^2 - y^2$  , is the required PDE.

9.  $f(x^2 + 2yz, y^2 + 2zx) = 0$

**Sol:** Given  $f(x^2 + 2yz, y^2 + 2zx) = 0$

Let  $u = x^2 + 2yz$

$v = y^2 + 2zx$

$$\frac{\partial u}{\partial x} = 2x + 2y \frac{\partial z}{\partial x}$$

$$\frac{\partial v}{\partial x} = 0 + 2x \cdot \frac{\partial z}{\partial x} + 2z. 1$$

$$\frac{\partial u}{\partial x} = 2x + 2yp$$

$$\frac{\partial v}{\partial x} = 2xp + 2z$$

$$\frac{\partial u}{\partial y} = 0 + 2y \cdot \frac{\partial z}{\partial y} + 2z. 1$$

$$\frac{\partial v}{\partial y} = 2y + 2x \frac{\partial z}{\partial y}$$

$$\frac{\partial u}{\partial y} = 2yq + 2z$$

$$\frac{\partial v}{\partial y} = 2y + 2xq$$

Now  $f(u, v) = \begin{vmatrix} \frac{\partial u}{\partial x} & \frac{\partial u}{\partial y} \\ \frac{\partial v}{\partial x} & \frac{\partial v}{\partial y} \end{vmatrix}$

$$f(u, v) = 0$$

$$\begin{vmatrix} (2x + 2yp) & (2yq + 2z) \\ (2z + 2xp) & (2y + 2xq) \end{vmatrix} = 0$$

$$(2x + 2yp)(2y + 2xq) - (2yq + 2z)(2z + 2xp) = 0$$

$$4xy + 4x^2q + 4y^2p + 4xypq - 4zyq - 4xypq - 4z^2 - 4xzp = 0 \quad \div \text{ by } 4$$

$$xy + x^2q + y^2p - zyq - z^2 - xzp = 0$$

$$x^2q + y^2p - zyq - xzp = z^2 - xy$$

$p(y^2 - xz) + q(x^2 - yz) = z^2 - xy$ , is the required PDE.

$$10. f\left(\frac{xy}{z}, z\right) = 0$$

Sol: Given  $f\left(\frac{xy}{z}, z\right) = 0$

$$\text{Let } u = \frac{xy}{z}$$

$$v = z$$

$$\frac{\partial u}{\partial x} = y \cdot \frac{(z \cdot 1 - x \cdot \frac{\partial z}{\partial x})}{z^2}$$

$$\frac{\partial v}{\partial x} = \frac{\partial z}{\partial x}$$

$$\frac{\partial u}{\partial x} = \frac{y(z - xp)}{z^2}$$

$$\frac{\partial v}{\partial x} = p$$

$$\frac{\partial u}{\partial y} = x \cdot \frac{(z \cdot 1 - y \cdot \frac{\partial z}{\partial y})}{z^2}$$

$$\frac{\partial v}{\partial y} = \frac{\partial z}{\partial y}$$

$$\frac{\partial u}{\partial y} = \frac{x(z - yq)}{z^2}$$

$$\frac{\partial v}{\partial y} = q$$

$$\text{Now } f(u, v) = \begin{vmatrix} \frac{\partial u}{\partial x} & \frac{\partial u}{\partial y} \\ \frac{\partial v}{\partial x} & \frac{\partial v}{\partial y} \end{vmatrix}$$

$$f(u, v) = 0$$

$$\begin{vmatrix} \frac{y(z - xp)}{z^2} & \frac{x(z - yq)}{z^2} \\ p & q \end{vmatrix} = 0$$

$$\frac{y(z - xp)}{z^2} \cdot q - \frac{x(z - yq)}{z^2} \cdot p = 0$$

$$\frac{yq(z - xp)}{z^2} - \frac{xp(z - yq)}{z^2} = 0$$

$$\frac{yq(z - xp) - xp(z - yq)}{z^2} = 0$$

$$\frac{yqz - xppq - xzq + xypq}{z^2} = 0$$

$$yqz - xzq = 0 \quad ;$$

$$z(yq - xq) = 0$$

$yq - xp = 0$ , is the required PDE.

$$11. z = yf(x) + x\varphi(y)$$

**Sol:** Given  $z = yf(x) + x\varphi(y)$  --- (1)

Differentiate (1) partially

$$\frac{\partial z}{\partial x} = y \cdot f'(x) + \varphi(y) \cdot 1$$

$$p = yf'(x) + \varphi(y) \quad \text{--- (2)}$$

$$\frac{\partial z}{\partial y} = f(x) \cdot 1 + x \cdot \varphi'(y)$$

$$q = f(x) + x\varphi'(y) \quad \text{--- (3)}$$

$$\frac{\partial^2 z}{\partial x^2} = y \cdot f''(x) + 0$$

$$r = yf''(x) \quad \text{--- (4)}$$

$$\frac{\partial}{\partial y} \left( \frac{\partial z}{\partial x} \right) = f'(x) \cdot 1 + \varphi'(y)$$

$$\frac{\partial^2 z}{\partial y \cdot \partial x} = f'(x) + \varphi'(y)$$

$$s = f'(x) + \varphi'(y) \quad \text{--- (5)}$$

$$\frac{\partial^2 z}{\partial y^2} = 0 + x\varphi''(y)$$

$$t = x\varphi''(y) \quad \text{--- (6)}$$

$$(1) * x + (2) * y$$

$$px + qy = xyf'(x) + x\varphi(y) + yf(x) + xy\varphi'(y)$$

$$px + qy = [x\varphi(y) + yf(x)] + xy[f'(x) + \varphi'(y)]$$

$$px + qy = z + xys \quad \text{From (1) and (5)}$$

$px + qy - xys = z$ , is the required PDE.

$$12. z = f(y + x) + g(y + 2x)$$

**Sol:** Given  $z = f(y + x) + g(y + 2x)$  --- (1)

Differentiate (1) partially

$$\frac{\partial z}{\partial x} = f'(y + x) + 2g'(y + 2x)$$

$$p = f' + 2g' \quad \text{--- (2)}$$

$$\frac{\partial z}{\partial y} = f'(y + x) + g'(y + 2x)$$

$$q = f' + g' \quad \text{--- (3)}$$

$$\frac{\partial^2 z}{\partial x^2} = f''(y + x) + 4g''(y + 2x)$$

$$r = f'' + 4g'' \quad \text{--- (4)}$$

$$\frac{\partial^2 z}{\partial x \partial y} = f''(y + x) + 4g''(y + 2x)$$

$$s = f'' + 2g'' \quad \text{--- (5)}$$

$$\frac{\partial^2 z}{\partial y^2} = f''(y + x) + g''(y + 2x)$$

$$t = f'' + g'' \quad \text{--- (6)}$$

$$(4) - (5)$$

$$r - s = f'' + 4g'' - f'' - 2g''$$

$$r - s = 2g'' \quad \text{--- (7)}$$

$$(5) - (6)$$

$$s - t = f'' + 2g'' - f'' - g''$$

$$s - t = g'' \quad \text{--- (8)}$$

$$(7) \Rightarrow r - s = 2(s - t) \quad \text{From (8)}$$

$$r - s = 2s - 2t$$

$$r - s - 2s + 2t = 0$$

$$r - 3s + 2t = 0, \text{ is the required PDE.}$$

$$13. z = f_1(y - 2x) + f_2(2y - x)$$

$$\text{Sol: Given } z = f_1(y - 2x) + f_2(2y - x) \quad \text{--- (1)}$$

Differentiate (1) partially

$$\frac{\partial z}{\partial x} = -2f_1'(y - 2x) - f_2'(2y - x)$$

$$p = -2f_1' - f_2' \quad \text{--- (2)}$$

$$\frac{\partial z}{\partial y} = f_1'(y - 2x) + 2f_2'(2y - x)$$

$$q = f_1' + 2f_2' \quad \text{--- (3)}$$

$$\frac{\partial^2 z}{\partial x^2} = 4f_1''(y - 2x) + f_2''(2y - x)$$

$$r = 4f_1'' + f_2'' \quad \text{--- (4)}$$

$$\frac{\partial}{\partial y} \left( \frac{\partial z}{\partial x} \right) = -2f_1''(y - 2x) - 2f_2''(2y - x)$$

$$s = -2f_1'' - 2f_2'' \quad \text{--- (5)}$$

$$\frac{\partial^2 z}{\partial y^2} = f_1''(y - 2x) + 4f_2''(2y - x)$$

$$t = f_1'' + 4f_2'' \quad \text{--- (6)}$$

Now

$$r + 2s = 4f_1'' + f_2'' - 4f_1'' - 4f_2''$$

$$r + 2s = -3f_2'' \quad \text{--- (7)}$$

Also

$$s + 2t = -2f_1'' - 2f_2'' + 2f_1'' + 8f_2''$$

$$s + 2t = 6f_2'' \quad \text{--- (8)}$$

$$(8) \div (7)$$

$$\frac{s+2t}{r+2s} = \frac{6f_2''}{-3f_2''}$$

$$\frac{s+2t}{r+2s} = -2$$

$$s + 2t = -2(r + 2s)$$

$$s + 2t = -2r - 4s$$

$$s + 2t + 2r + 4s = 0$$

**5s + 2t + 2r = 0**, is the required PDE.

$$14. z = f(x) + e^y g(x)$$

**Sol:** Given  $z = f(x) + e^y g(x)$  --- (1)

Differentiate (1) partially

$$\frac{\partial z}{\partial x} = f'(x) + e^y g'(x)$$

$$p = f'(x) + e^y g'(x) \quad \text{--- (2)}$$

$$\frac{\partial z}{\partial y} = e^y g(x)$$

$$q = e^y g(x) \quad \text{--- (3)}$$

$$\frac{\partial^2 z}{\partial x^2} = f''(x) + e^y g''(x)$$

$$r = f''(x) + e^y g''(x) \quad \text{--- (4)}$$

$$\frac{\partial}{\partial y} \left( \frac{\partial z}{\partial x} \right) = 0 + e^y g'(x)$$

$$s = e^y g'(x) \quad \text{--- (5)}$$

$$\frac{\partial^2 z}{\partial y^2} = e^y g(x)$$

$$t = e^y g(x) \quad \text{--- (6)}$$

From (3) and (6)

$$q = t$$

$t - q = 0$  , is the required the PDE.

$$15. z = f(x + ct) + g(x - ct)$$

$$\text{Sol: Given } z = f(x + ct) + g(x - ct) \quad \text{--- (1)}$$

$$\frac{\partial z}{\partial x} = f'(x + ct) + g'(x - ct)$$

$$p = f' + g' \quad \text{--- (2)}$$

$$\frac{\partial z}{\partial t} = cf'(x + ct) - cg'(x - ct)$$

$$q = cf' - cg' \quad \text{--- (3)}$$

$$\frac{\partial^2 z}{\partial x^2} = f''(x + ct) + g''(x - ct)$$

$$r = f'' + g'' \quad \text{--- (4)}$$

$$\frac{\partial}{\partial t} \left( \frac{\partial z}{\partial x} \right) = cf''(x + ct) - cg''(x - ct)$$

$$s = cf'' - cg'' \quad \text{--- (5)}$$

$$\frac{\partial^2 z}{\partial t^2} = c^2 f''(x + ct) + c^2 g''(x - ct)$$

$$t = c^2 f'' + c^2 g'' \quad \text{--- (6)}$$

Consider

$$t = c^2 f'' + c^2 g''$$

$$t = c^2 [f'' + g'']$$

$$t = c^2 r$$

$t - c^2 r = 0$  , is the required PDE.

### *Solution of Non Homogeneous PDE by Direct Integration*

$$1. \text{ Solve } \frac{\partial^2 u}{\partial x^2} = x + y$$

$$\text{Sol: Given } \frac{\partial^2 u}{\partial x^2} = x + y$$

$$\frac{\partial}{\partial x} \left( \frac{\partial u}{\partial x} \right) = x + y$$

Integrate w.r.t 'x'

$$\frac{\partial u}{\partial x} = \int x dx + y \int 1 dx$$

$$\frac{\partial u}{\partial x} = \frac{x^2}{2} + yx + f(y)$$

Again integrating w.r.t 'x'

$$u = \frac{1}{2} \int x^2 dx + y \int x dx + f(y) \int 1 dx$$

$$u = \frac{1}{2} \left[ \frac{x^3}{3} \right] + y \left[ \frac{x^2}{2} \right] + f(y).x + g(y)$$

$$\mathbf{u = \frac{x^3}{6} + \frac{x^2 y}{2} + x f(y) + g(y), is the required solution.}$$

$$\mathbf{2. Solve \frac{\partial^2 z}{\partial x \partial y} = \frac{x}{y} + a}$$

$$\mathbf{Sol: Given \frac{\partial^2 z}{\partial x \partial y} = \frac{x}{y} + a}$$

$$\frac{\partial}{\partial x} \left( \frac{\partial z}{\partial y} \right) = \frac{x}{y} + a$$

Integrate w.r.t 'x'

$$\frac{\partial z}{\partial y} = \frac{1}{y} \int x dx + a \int 1 dx$$

$$\frac{\partial z}{\partial y} = \frac{x^2}{2y} + ax + f(y)$$

Integrate w.r.t 'y'

$$z = \frac{x^2}{2} \int \frac{1}{y} dy + ax \int 1 dy + \int f(y) dy$$

$$\mathbf{z = \frac{x^2}{2} \log y + axy + F(y) + g(x), is the required solution.}$$

$$\mathbf{3. Solve \frac{\partial^3 z}{\partial x^2 \partial y} = \cos(2x + 3y)}$$

$$\mathbf{Sol: Given \frac{\partial^3 z}{\partial x^2 \partial y} = \cos(2x + 3y)}$$

$$\frac{\partial}{\partial x} \left( \frac{\partial^2 z}{\partial x \partial y} \right) = \cos(2x + 3y)$$

Integrate w.r.t 'x'

$$\frac{\partial^2 z}{\partial x \partial y} = \int \cos(2x + 3y) dx$$

$$\frac{\partial^2 z}{\partial x \partial y} = \frac{\sin(2x+3y)}{2} + f(y)$$

$$\frac{\partial}{\partial x} \left( \frac{\partial z}{\partial y} \right) = \frac{\sin(2x+3y)}{2} + f(y)$$

Integrating w.r.t 'x'

$$\frac{\partial z}{\partial y} = \frac{1}{2} \int \sin(2x + 3y) dx + f(y) \int 1 dx$$

$$\frac{\partial z}{\partial y} = \frac{-\cos(2x+3y)}{2.2} + f(y).x + g(y)$$

Integrating w.r.t 'y'

$$z = -\frac{1}{4} \int \cos(2x + 3y) dy + x \int f(y) dy + \int g(y) dy$$

$$z = -\frac{1}{4} \cdot \frac{\sin(2x+3y)}{3} + xF(y) + G(y) + h(x)$$

$$z = -\frac{\sin(2x+3y)}{12} + xF(y) + G(y) + h(x), \text{ is the required solution.}$$

4. Solve  $\frac{\partial^2 z}{\partial x \partial y} = \sin x \sin y$  for which  $\frac{\partial z}{\partial y} = -2\sin y$  when  $x = 0$  and  $z = 0$  if  $y$  is an odd multiple of  $\frac{\pi}{2}$ . {or  $z = 0$  if  $y = (2n + 1)\frac{\pi}{2}$ }

**Sol:** Given  $\frac{\partial^2 z}{\partial x \partial y} = \sin x \sin y$

$$\frac{\partial}{\partial x} \left( \frac{\partial z}{\partial y} \right) = \sin x \sin y$$

Integrate w.r.t 'x'

$$\frac{\partial z}{\partial y} = \sin y \int \sin x dx$$

$$\frac{\partial z}{\partial y} = \sin y (-\cos x) + f(y) \quad \text{--- (1)}$$

Integrate w.r.t 'y'

$$z = -\cos x \int \sin y dy + \int f(y) dy$$

$$z = -\cos x (-\cos y) + F(y) + g(x)$$

$$z = \cos x \cdot \cos y + F(y) + g(x) \quad \text{--- (2)}$$

By data  $\frac{\partial z}{\partial y} = -2\sin y$  when  $x = 0$

$$(1) \Rightarrow -2\sin y = \sin y (-\cos 0) + f(y)$$

Since  $\cos 0 = 1$

$$-2\sin y = -\sin y + f(y)$$

$$f(y) = -2\sin y + \sin y$$

$$f(y) = -\sin y$$

Now

$$F(y) = \int f(y) dy$$

$$F(y) = - \int \sin y dy$$

$$F(y) = -(-\cos y)$$

$$F(y) = \cos y$$

$$(2) \Rightarrow z = \cos x \cdot \cos y + \cos y + g(x)$$

Again by data  $z = 0$  if  $y = (2n + 1) \frac{\pi}{2}$

$$0 = \cos x \cdot \cos \left[ (2n + 1) \frac{\pi}{2} \right] + \cos \left[ (2n + 1) \frac{\pi}{2} \right] + g(x) \quad \cos \left[ (2n + 1) \frac{\pi}{2} \right] = 0$$

$$g(x) = 0$$

Thus,

$$(2) \Rightarrow z = \cos x \cdot \cos y + \cos y + 0$$

$$z = \cos x \cdot \cos y + \cos y$$

$$z = \cos y (\cos x + 1), \text{ is the solution.}$$

5. Solve  $\frac{\partial^2 u}{\partial x \partial t} = e^{-t} \cos x$  given that  $u = 0$  when  $t = 0$  and  $\frac{\partial u}{\partial t} = 0$  at  $x = 0$ . Also show that  $u \rightarrow \sin x$  as  $t \rightarrow \infty$ .

**Sol:** Given  $\frac{\partial^2 u}{\partial x \partial t} = e^{-t} \cos x$

$$\frac{\partial}{\partial x} \left( \frac{\partial u}{\partial t} \right) = e^{-t} \cos x$$

Integrate w.r.t 'x'

$$\frac{\partial u}{\partial t} = e^{-t} \int \cos x dx$$

$$\frac{\partial u}{\partial t} = e^{-t} \sin x + f(t) \quad \text{--- (1)}$$

Integrate w.r.t 't'

$$u = \sin x \int e^{-t} dt + \int f(t) dt + g(x)$$

$$u = \sin x \left[ \frac{e^{-t}}{-1} \right] + F(t) + g(x)$$

$$u = -e^{-t} \sin x + F(t) + g(x) \quad \text{--- (2)}$$

By data  $\frac{\partial u}{\partial t} = 0$  at  $x = 0$

$$(1) \Rightarrow 0 = e^{-t} (\sin 0) + f(t)$$

Since  $\sin 0 = 0$

$$f(t) = 0$$

Now

$$F(t) = \int f(t)dt$$

$$F(t) = 0$$

$$(2) \Rightarrow u = -e^{-t} \sin x + 0 + g(x)$$

$$u = -e^{-t} \sin x + g(x)$$

Also given  $u = 0$  when  $t = 0$

$$0 = -e^{-0} \sin x + g(x)$$

Since  $e^{-0} = 1$

$$0 = -\sin x + g(x)$$

$$g(x) = \sin x$$

Thus,

$$(2) \Rightarrow u = -e^{-t} \sin x + 0 + \sin x$$

$$u = \sin x(1 - e^{-t}), \text{ is the solution.}$$

As  $t \rightarrow \infty$

$$u = \sin x(1 - e^{-\infty})$$

$$u = \sin x(1 - 0)$$

$$u = \sin x$$

$\therefore u \rightarrow \sin x$  as  $t \rightarrow \infty$

6. Solve  $\frac{\partial^2 z}{\partial x \partial y} = \frac{x}{y}$  subject to  $z = 0$  when  $x = 1$  and  $\frac{\partial z}{\partial x} = \log x$  when  $y = 1$ .

**Sol:** Given  $\frac{\partial^2 z}{\partial x \partial y} = \frac{x}{y}$

$$\frac{\partial^2 z}{\partial y \partial x} = \frac{x}{y}$$

$$\frac{\partial}{\partial y} \left( \frac{\partial z}{\partial x} \right) = \frac{x}{y}$$

Integrate w.r.t 'y'

$$\frac{\partial z}{\partial x} = x \int \frac{1}{y} dy$$

$$\frac{\partial z}{\partial x} = x \log y + f(x) \quad \text{--- (1)}$$

Integrate w.r.t 'x'

$$z = \log y \int x dx + \int f(x) dx$$

$$z = \log y \left[ \frac{x^2}{2} \right] + F(x) + g(y) \quad \text{--- (2)}$$

By data  $\frac{\partial z}{\partial x} = \log x$  when  $y = 1$

$$(1) \Rightarrow \log x = x \log 1 + f(x)$$

Since  $\log 1 = 0$

$$f(x) = \log x$$

Now

$$F(x) = \int f(x) dx$$

$$F(x) = \int \log x \cdot 1 dx$$

$$F(x) = x \log x - \int \frac{1}{x} \cdot x dx$$

$$F(x) = x \log x - x$$

$$(2) \Rightarrow z = \frac{x^2 \log y}{2} + x \log x - x + g(y)$$

Also given  $z = 0$  when  $x = 1$

$$0 = \frac{1 \cdot \log y}{2} + 1 \cdot \log 1 - 1 + g(y)$$

Since  $\log 1 = 0$

$$0 = \frac{\log y}{2} - 1 + g(y)$$

$$g(y) = 1 - \frac{\log y}{2}$$

Thus,

$$z = \frac{x^2 \log y}{2} + x \log x - x + 1 - \frac{\log y}{2}$$

$$z = \frac{\log y}{2} (x^2 - 1) + x(\log x - 1) + 1, \text{ is the required solution.}$$

7. Solve  $\frac{\partial^2 z}{\partial x^2} = xy$  subject to the conditions that  $\frac{\partial z}{\partial x} = \log(1 + y)$  when  $x = 1$  and  $z = 0$  when  $x = 0$ .

Sol: Given  $\frac{\partial^2 z}{\partial x^2} = xy$

$$\frac{\partial}{\partial x} \left( \frac{\partial z}{\partial x} \right) = xy$$

Integrate w.r.t 'x'

$$\frac{\partial z}{\partial x} = y \int x dx$$

$$\frac{\partial z}{\partial x} = y \cdot \frac{x^2}{2} + f(y) \quad \text{--- (1)}$$

Integrate w.r.t 'x'

$$z = \frac{y}{2} \int x^2 dx + f(y) \int 1 dx$$

$$z = \frac{y}{2} \left[ \frac{x^3}{3} \right] + xf(y) + g(y)$$

$$z = \frac{x^3 y}{6} + xf(y) + g(y) \quad \dots (2)$$

By data  $\frac{\partial z}{\partial x} = \log(1 + y)$  when  $x = 1$

$$(1) \Rightarrow \log(1 + y) = \frac{y}{2} + f(y)$$

$$f(y) = \log(1 + y) - \frac{y}{2}$$

$$(2) \Rightarrow z = \frac{x^3 y}{6} + x \left[ \log(1 + y) - \frac{y}{2} \right] + g(y)$$

Also by data  $z = 0$  when  $x = 0$

$$0 = 0 + 0 + g(y)$$

$$g(y) = 0$$

Thus,

$$z = \frac{x^3 y}{6} + x \left[ \log(1 + y) - \frac{y}{2} \right] + 0$$

$$z = \frac{x^3 y}{6} + x \left[ \log(1 + y) - \frac{y}{2} \right], \text{ is the required solution.}$$

***Solution of Homogeneous PDE involving derivatives with respect to one independent variable only***

1. Solve  $\frac{\partial^2 z}{\partial x^2} + z = 0$  given that when  $x = 0$ ,  $z = e^y$  and  $\frac{\partial z}{\partial x} = 1$ .

**Sol:** Given  $\frac{\partial^2 z}{\partial x^2} + z = 0$

$$(D^2 + 1)z = 0$$

$$\text{A.E : } m^2 + 1 = 0$$

$$m^2 = -1$$

$$m = \pm \sqrt{-1}$$

$$m = \pm i$$

$$z_c = e^{0 \cdot x} [c_1 \cos x + c_2 \sin x]$$

The G.S is

$$z = z_c$$

$$z = c_1 \cos x + c_2 \sin x$$

The solution for PDE is

$$z = f(y) \cos x + g(y) \sin x \quad \dots (1)$$

By data, When  $x = 0, z = e^y$

$$(1) \Rightarrow e^y = f(y) \cos(0) + g(y) \sin(0) \quad [ \sin(0) = 0, \cos(0) = 1 ]$$

$$e^y = f(y)$$

$$f(y) = e^y$$

Differentiate (1) w.r.t 'x'

$$\frac{\partial z}{\partial x} = -f(y) \sin x + g(y) \cos x \quad \dots (2)$$

when  $\frac{\partial z}{\partial x} = 1$  and  $x = 0$

$$(2) \Rightarrow 1 = -f(y) \sin(0) + g(y) \cos(0) \quad [ \sin(0) = 0, \cos(0) = 1 ]$$

$$1 = g(y)$$

$$g(y) = 1$$

$$\therefore (1) \Rightarrow z = e^y \cos x + 1 \cdot \sin x$$

$z = e^y \cos x + \sin x$ , is the solution.

2. Solve  $\frac{\partial^2 z}{\partial x^2} = a^2 z$  given that when  $x = 0, z = 0$  and  $\frac{\partial z}{\partial x} = a \sin y$ .

**Sol:** Given  $\frac{\partial^2 z}{\partial x^2} - a^2 z = 0$

$$(D^2 - a^2)z = 0$$

$$\text{A.E : } m^2 - a^2 = 0$$

$$m^2 = a^2$$

$$m = \pm \sqrt{a^2}$$

$$m = \pm a$$

$$z_c = c_1 e^{ax} + c_2 e^{-ax}$$

The G.S is

$$z = z_c$$

$$z = c_1 e^{ax} + c_2 e^{-ax}$$

The solution for PDE is

$$z = f(y) e^{ax} + g(y) e^{-ax} \quad \dots (1)$$

By data, When  $x = 0, z = 0$

$$(1) \Rightarrow 0 = f(y) e^0 + g(y) e^{-0} \quad [e^0 = 1]$$

$$0 = f(y) + g(y)$$

$$f(y) + g(y) = 0 \quad \dots (2)$$

Differentiate (1) w.r.t 'x'

$$\frac{\partial z}{\partial x} = af(y)e^{ax} - ag(y)e^{-ax} \quad \dots (3)$$

when  $\frac{\partial z}{\partial x} = asiny$  and  $x = 0$

$$(3) \Rightarrow asiny = af(y)e^0 - ag(y)e^{-0} \quad [e^0 = 1]$$

$$asiny = a.f(y) - a.g(y)$$

$$f(y) - g(y) = siny$$

$$f(y) - g(y) = siny \quad \dots (4)$$

(4) + (2), we get

$$f(y) - g(y) = siny$$

$$f(y) + g(y) = 0$$

---

$$2f(y) = siny$$

$$f(y) = \frac{siny}{2}$$

$$\therefore (1) \Rightarrow z = \left(\frac{siny}{2}\right)e^{ax} + \left(-\frac{siny}{2}\right)e^{-ax}$$

$$z = \frac{siny}{2}[e^{ax} - e^{-ax}] \text{ , is the solution.}$$

3. Solve  $\frac{\partial^2 z}{\partial y^2} = z$  given that when  $y = 0, z = e^x$  and  $\frac{\partial z}{\partial y} = e^{-x}$

**Sol:** Given  $\frac{\partial^2 z}{\partial y^2} - z = 0$

$$(D^2 - 1)z = 0$$

A.E :  $m^2 - 1 = 0$

$$m^2 = 1$$

$$m = \pm\sqrt{1}$$

$$m = \pm 1$$

$$z_c = c_1 e^y + c_2 e^{-y}$$

The G.S is

$$z = z_c$$

$$z = c_1 e^y + c_2 e^{-y}$$

(4) - (2), we get

$$f(y) - g(y) = siny$$

$$f(y) + g(y) = 0$$

---

$$-2g(y) = siny$$

$$g(y) = -\frac{siny}{2}$$

The solution for PDE is

$$z = f(x)e^y + g(x)e^{-y} \quad \dots (1)$$

By data, When  $y = 0, z = e^x$

$$(1) \Rightarrow e^x = f(x)e^0 + g(x)e^{-0} \quad [e^0 = 1]$$

$$e^x = f(x) + g(x)$$

$$f(x) + g(x) = e^x \quad \dots (2)$$

Differentiate (1) w.r.t 'y'

$$\frac{\partial z}{\partial y} = f(x)e^y - g(x)e^{-y} \quad \dots (3)$$

When  $\frac{\partial z}{\partial y} = e^{-x}$  and  $y = 0$

$$(3) \Rightarrow e^{-x} = f(x)e^0 - g(x)e^{-0} \quad [e^0 = 1]$$

$$e^{-x} = f(x) - g(x)$$

$$f(x) - g(x) = e^{-x} \quad \dots (4)$$

(2) + (4), we get

$$f(x) + g(x) = e^x$$

$$f(x) - g(x) = e^{-x}$$

~~$$2f(x) = e^x + e^{-x}$$~~

$$f(x) = \frac{e^x + e^{-x}}{2}$$

$$f(x) = \cosh x$$

$$\therefore (1) \Rightarrow z = (\cosh x)e^y + (\sinh x)e^{-y}$$

$z = e^y \cosh x + e^{-y} \sinh x$ , is the solution.

(2) - (4), we get

$$f(x) + g(x) = e^x$$

$$f(x) - g(x) = e^{-x}$$

~~$$2g(x) = e^x - e^{-x}$$~~

$$g(x) = \frac{e^x - e^{-x}}{2}$$

$$g(x) = \sinh x$$

4. Solve  $\frac{\partial^2 u}{\partial x^2} + u = 0$  where  $u$  satisfy the conditions i)  $u(0, y) = e^{1/2}$

ii)  $\frac{\partial u}{\partial x}(0, y) = 1$ .

**Sol:** Given  $\frac{\partial^2 u}{\partial x^2} + u = 0$

$$(D^2 + 1)u = 0$$

A.E :  $m^2 + 1 = 0$

$$m^2 = -1$$

$$m = \pm\sqrt{-1}$$

$$m = \pm i$$

$$u_c = e^{0x}[c_1 \cos x + c_2 \sin x]$$

The G.S is

$$u = u_c$$

$$u = c_1 \cos x + c_2 \sin x$$

The solution for PDE is

$$u = f(y) \cos x + g(y) \sin x \quad \text{--- (1)}$$

By data, When  $x = 0, u = e^{1/2}$

$$(1) \Rightarrow e^{1/2} = f(y) \cos(0) + g(y) \sin(0) \quad [\sin(0) = 0, \cos(0) = 1]$$

$$e^{1/2} = f(y)$$

$$f(y) = \sqrt{e}$$

Differentiate (1) w.r.t 'x'

$$\frac{\partial u}{\partial x} = -f(y) \sin x + g(y) \cos x \quad \text{--- (2)}$$

When  $\frac{\partial u}{\partial x} = 1$  and  $x = 0$

$$(2) \Rightarrow 1 = -f(y) \sin(0) + g(y) \cos(0) \quad [\sin(0) = 0, \cos(0) = 1]$$

$$1 = g(y)$$

$$g(y) = 1$$

$$\therefore (1) \Rightarrow z = \sqrt{e} \cos x + 1 \cdot \sin x$$

$$z = \sqrt{e} \cos x + \sin x, \text{ is the solution.}$$

5. Solve  $\frac{\partial^2 z}{\partial x^2} = a^2 z$  given that when  $x = 0, \frac{\partial z}{\partial x} = a \sin y$  and  $\frac{\partial z}{\partial y} = 0$ .

**Sol:** Given  $\frac{\partial^2 z}{\partial x^2} - a^2 z = 0$

$$(D^2 - a^2)z = 0$$

$$\text{A.E : } m^2 - a^2 = 0$$

$$m^2 = a^2$$

$$m = \pm\sqrt{a^2}$$

$$m = \pm a$$

$$z_c = c_1 e^{ax} + c_2 e^{-ax}$$

The G.S is

$$z = z_c$$

$$z = c_1 e^{ax} + c_2 e^{-ax}$$

The solution for PDE is

$$z = f(y)e^{ax} + g(y)e^{-ax} \quad \text{--- (1)}$$

Differentiate (1) w.r.t 'x' partially

$$\frac{\partial z}{\partial x} = af(y)e^{ax} - ag(y)e^{-ax}$$

When  $\frac{\partial z}{\partial x} = asiny$  and  $x = 0$

$$asiny = af(y)e^0 - ag(y)e^{-0} \quad [e^0 = 1]$$

$$asiny = a.f(y) - a.g(y)$$

$$f(y) - g(y) = siny$$

$$f(y) - g(y) = siny \quad \text{--- (2)}$$

Differentiate (1) w.r.t 'y' partially

$$\frac{\partial z}{\partial y} = f'(y)e^{ax} + g'(y)e^{-ax}$$

When  $\frac{\partial z}{\partial y} = 0$  and  $x = 0$

$$0 = f'(y)e^0 + g'(y)e^{-0} \quad [e^0 = 1]$$

$$f'(y) + g'(y) = 0$$

Integrate w.r.t 'y'

$$f(y) + g(y) = k \quad \text{--- (3)}$$

(3) + (2), we get

(3) - (2), we get

$$f(y) - g(y) = siny$$

$$f(y) + g(y) = k$$

---

$$2f(y) = siny + k$$

$$f(y) = \frac{k+siny}{2}$$

$$\therefore (1) \Rightarrow z = \left(\frac{k+siny}{2}\right)e^{ax} + \left(\frac{k-siny}{2}\right)e^{-ax}$$

$$z = \frac{ke^{ax} + e^{ax}siny + ke^{-ax} - e^{-ax}siny}{2}$$

$$z = \frac{k[e^{ax} + e^{-ax}] + siny[e^{ax} - e^{-ax}]}{2}$$

$$z = \frac{k[2coshax] + siny[2sinhax]}{2}$$

$$f(y) - g(y) = siny$$

$$f(y) + g(y) = k$$

---

$$-2g(y) = siny - k$$

$$g(y) = \frac{k-siny}{2}$$

$z = k \cosh ax + \sin y \sinh ax$ , is the solution.

6. Solve  $\frac{\partial^2 z}{\partial y^2} = z$  given that  $z = 0$  and  $\frac{\partial z}{\partial y} = \sin x$  when  $y = 0$ .

**Sol:** Given  $\frac{\partial^2 z}{\partial y^2} - z = 0$

$$(D^2 - 1)z = 0$$

A.E :  $m^2 - 1 = 0$

$$m^2 = 1$$

$$m = \pm\sqrt{1}$$

$$m = \pm 1$$

$$z_c = c_1 e^y + c_2 e^{-y}$$

The G.S is

$$z = z_c$$

$$z = c_1 e^y + c_2 e^{-y}$$

The solution for PDE is

$$z = f(x)e^y + g(x)e^{-y} \quad \text{--- (1)}$$

By data, When  $y = 0, z = 0$

$$(1) \Rightarrow 0 = f(x)e^0 + g(x)e^{-0} \quad [e^0 = 1]$$

$$0 = f(x) + g(x)$$

$$f(x) + g(x) = 0 \quad \text{--- (2)}$$

Differentiate (1) w.r.t 'y'

$$\frac{\partial z}{\partial y} = f(x)e^y - g(x)e^{-y} \quad \text{--- (3)}$$

When  $\frac{\partial z}{\partial y} = \sin x$  and  $y = 0$

$$(3) \Rightarrow \sin x = f(x)e^0 - g(x)e^{-0} \quad [e^0 = 1]$$

$$\sin x = f(x) - g(x)$$

$$f(x) - g(x) = \sin x \quad \text{--- (4)}$$

(2) + (4), we get

$$f(x) + g(x) = 0$$

$$f(x) - g(x) = \sin x$$

---

$$2f(x) = \sin x$$

(2) - (4), we get

$$f(x) + g(x) = 0$$

$$f(x) - g(x) = \sin x$$

---

$$2g(x) = -\sin x$$

$$f(x) = \frac{\sin x}{2}$$

$$g(x) = -\frac{\sin x}{2}$$

$$\therefore (1) \Rightarrow z = \left(\frac{\sin x}{2}\right)e^y + \left(-\frac{\sin x}{2}\right)e^{-y}$$

$$z = \sin x \left[\frac{e^y - e^{-y}}{2}\right]$$

$z = \sin x \sinh y$ , is the solution.

7. Solve  $\frac{\partial^2 z}{\partial x^2} + 3\frac{\partial z}{\partial x} - 4z = 0$  subject to the condition  $z = 1$  &  $\frac{\partial z}{\partial x} = y$  when  $x = 0$ .

**Sol:** Given  $\frac{\partial^2 z}{\partial x^2} + 3\frac{\partial z}{\partial x} - 4z = 0$

$$(D^2 + 3D - 4)z = 0$$

A.E :  $m^2 + 3m - 4 = 0$

$$m^2 + 4m - m - 4 = 0$$

$$m(m + 4) - 1(m + 4) = 0$$

$$(m - 1)(m + 4) = 0$$

$$m = 1, -4$$

$$z_c = c_1 e^x + c_2 e^{-4x}$$

The G.S is

$$z = z_c$$

$$z = c_1 e^x + c_2 e^{-4x}$$

The solution for PDE is

$$z = f(y)e^x + g(y)e^{-4x} \quad \dots (1)$$

By data, When  $x = 0, z = 1$

$$(1) \Rightarrow 1 = f(y)e^0 + g(y)e^{-0} \quad [e^0 = 1]$$

$$1 = f(y) + g(y)$$

$$f(y) + g(y) = 1 \quad \dots (2)$$

Differentiate (1) w.r.t 'x'

$$\frac{\partial z}{\partial x} = f(y)e^x - 4g(y)e^{-4x} \quad \dots (3)$$

When  $\frac{\partial z}{\partial x} = y$  and  $x = 0$

$$(3) \Rightarrow y = f(y)e^0 - 4g(y)e^{-0} \quad [e^0 = 1]$$

$$y = f(y) - 4g(y)$$

$$f(y) - 4g(y) = y \quad \dots (4)$$

4\*(2) + (4), we get

$$4f(y) + 4g(y) = 4$$

$$f(y) - 4g(y) = y$$

---

$$5f(y) = 4 + y$$

$$f(y) = \frac{4+y}{5}$$

$\therefore$  (1)  $\Rightarrow z = \left(\frac{4+y}{5}\right)e^x + \left(\frac{1-y}{5}\right)e^{-4x}$ , is the solution.

8. Solve  $\frac{\partial^2 u}{\partial x \partial y} = \frac{\partial u}{\partial x}$ , using the substitution  $\frac{\partial u}{\partial x} = v$ .

**Sol:** Given  $\frac{\partial^2 u}{\partial x \partial y} = \frac{\partial u}{\partial x}$

$$\frac{\partial}{\partial y} \left[ \frac{\partial u}{\partial x} \right] = \frac{\partial u}{\partial x} \quad \dots (1)$$

Let  $\frac{\partial u}{\partial x} = v$

$$(1) \Rightarrow \frac{\partial v}{\partial y} = v$$

$$\frac{\partial v}{\partial y} - v = 0$$

$$(D - 1)v = 0$$

A.E:  $m - 1 = 0$

$$m = 1$$

The solution is  $v = c_1 e^y$

Now,  $\frac{\partial u}{\partial x} = f(x)e^y$

Integrate w.r.t 'x'

$$u = e^y \int f(x) dx$$

$u = e^y F(x) + g(y)$ , is the solution.

(2) - (4), we get

$$f(y) + g(y) = 1$$

$$f(y) - 4g(y) = y$$

---

$$5g(y) = 1 - y$$

$$g(y) = \frac{1-y}{5}$$

### ***Solution of the Lagrange's linear PDE***

Lagrange's linear PDE is of the form  $Pp + Qq = R$ . Let us consider two equations:  
 $u(x, y, z) = c_1$ ,  $v(x, y, z) = c_2$  where  $c_1$  and  $c_2$  are constants.

By the rule of cross multiplication, we have

$$\frac{dx}{P} = \frac{dy}{Q} = \frac{dz}{R}$$

Above equation is regarded as a system of simultaneous equations in three variables and relations  $u(x, y, z) = c_1$ ,  $v(x, y, z) = c_2$  satisfy these equations.

Thus  $\varphi(u, v) = 0$  is a general solution of Lagrange's linear PDE.

### **Problems**

1. Solve  $yzp + xzq = xy$

**Sol:** Given  $(yz)p + (xz)q = xy$   
 $\langle Pp + Qq = R \rangle$

Here  $P = yz$      $Q = xz$      $R = xy$

Auxiliary equations

$$\frac{dx}{P} = \frac{dy}{Q} = \frac{dz}{R}$$

$$\frac{dx}{yz} = \frac{dy}{xz} = \frac{dz}{xy}$$

Comparing,

$$\frac{dx}{yz} = \frac{dy}{xz}$$

$$\frac{dy}{xz} = \frac{dz}{xy}$$

$$\frac{dx}{y} = \frac{dy}{x}$$

$$\frac{dy}{z} = \frac{dz}{y}$$

Integrating

Integrating

$$\int x dx = \int y dy$$

$$\int y dy = \int z dz$$

$$\frac{x^2}{2} = \frac{y^2}{2} + c_1$$

$$\frac{y^2}{2} = \frac{z^2}{2} + c_2$$

$$x^2 = y^2 + 2c_1$$

$$y^2 = z^2 + 2c_2$$

$$x^2 - y^2 = k_1$$

$$y^2 - z^2 = k_2$$

Thus the solution is,  $\varphi(u, v) = 0$

$$\varphi\left((x^2 - y^2), (y^2 - z^2)\right) = 0.$$

## 2. Solve $xzp + yzq = xy$

**Sol:** Given  $(xz)p + (yz)q = xy$

$$\langle Pp + Qq = R \rangle$$

Here  $P = xz$      $Q = yz$      $R = xy$

Auxiliary equations

$$\frac{dx}{P} = \frac{dy}{Q} = \frac{dz}{R}$$

$$\frac{dx}{xz} = \frac{dy}{yz} = \frac{dz}{xy}$$

Comparing,

$$\frac{dx}{xz} = \frac{dy}{yz}$$

$$\frac{dx}{x} = \frac{dy}{y}$$

Integrating

$$\int \frac{dx}{x} = \int \frac{dy}{y}$$

$$\log x = \log y + \log(c_1)$$

$$\log x = \log(c_1 y)$$

$$x = c_1 y$$

$$c_1 = \frac{x}{y}$$

Let the multipliers be  $y, x, -2z$

$$\therefore \text{Each fraction} = \frac{y dx + x dy - 2z dz}{xyz + xyz - 2xyz}$$

$$k = \frac{y dx + x dy - 2z dz}{0}$$

$$y dx + x dy - 2z dz = 0$$

$$d(xy) - 2z dz = 0$$

Integrating

$$xy - z^2 = c_2$$

Thus the solution is,  $\varphi(u, v) = 0$

$$\varphi\left(\left(\frac{x}{y}\right), (xy - z^2)\right) = 0.$$

3. Solve  $y^2p - xyq = x(z - 2y)$

**Sol:** Given  $(y^2)p + (-xy)q = x(z - 2y)$

$$\langle Pp + Qq = R \rangle$$

Here  $P = y^2$   $Q = -xy$   $R = x(z - 2y)$

Auxiliary equations

$$\frac{dx}{P} = \frac{dy}{Q} = \frac{dz}{R}$$

$$\frac{dx}{y^2} = \frac{dy}{-xy} = \frac{dz}{x(z-2y)}$$

Comparing,

$$\frac{dx}{y^2} = \frac{-dy}{xy}$$

$$\frac{dx}{y} = \frac{-dy}{x}$$

$$x dx = -y dy$$

Integrating

$$\int x dx = -\int y dy$$

$$\frac{x^2}{2} = -\frac{y^2}{2} + c_1$$

$$x^2 = -y^2 + 2c_1$$

$$x^2 + y^2 = k_1$$

$$\frac{dy}{-xy} = \frac{dz}{x(z-2y)}$$

$$\frac{dy}{-y} = \frac{dz}{(z-2y)}$$

$$-\frac{dy}{y} = \frac{dz}{(z-2y)}$$

$$(z - 2y)dy = -ydz$$

$$(z - 2y)dy + ydz = 0$$

$$zdy - 2ydy + ydz = 0$$

$$zdy + ydz - 2ydy = 0$$

$$d(yz) - 2ydy = 0$$

Integrating

$$yz - y^2 = c_2$$

Thus the solution is,  $\varphi(u, v) = 0$

$$\varphi(x^2 + y^2, yz - y^2) = 0.$$

4. Solve  $xp + yq = 3z$

**Sol:** Given  $(x)p + (y)q = 3z$

$$\langle Pp + Qq = R \rangle$$

Here  $P = x$   $Q = y$   $R = 3z$

Auxiliary equations

$$\frac{dx}{P} = \frac{dy}{Q} = \frac{dz}{R}$$

$$\frac{dx}{x} = \frac{dy}{y} = \frac{dz}{3z}$$

Comparing,

$$\frac{dx}{x} = \frac{dy}{y}$$

Integrating

$$\int \frac{dx}{x} = \int \frac{dy}{y}$$

$$\log x = \log y + \log(c_1)$$

$$\log x = \log(c_1 y)$$

$$x = c_1 y$$

$$c_1 = \frac{x}{y}$$

Thus the solution is,  $\varphi(u, v) = 0$

$$\varphi\left(\left(\frac{x}{y}\right), \left(\frac{y^3}{z}\right)\right) = 0.$$

5. Solve  $\frac{y^2 z}{x} p + xzq = y^2$

**Sol:** Given  $\left(\frac{y^2 z}{x}\right)p + (xz)q = y^2$

Multiply by 'x'

$$(y^2 z)p + (x^2 z)q = xy^2$$

$$\langle Pp + Qq = R \rangle$$

Here  $P = y^2 z$        $Q = x^2 z$        $R = xy^2$

Auxiliary equations

$$\frac{dx}{P} = \frac{dy}{Q} = \frac{dz}{R}$$

$$\frac{dx}{y^2 z} = \frac{dy}{x^2 z} = \frac{dz}{xy^2}$$

Comparing,

$$\frac{dx}{y^2 z} = \frac{dy}{x^2 z}$$

$$\frac{dx}{y^2} = \frac{dy}{x^2}$$

Integrating

$$\int x^2 dx = \int y^2 dy$$

$$\frac{dy}{y} = \frac{dz}{3z}$$

Integrating

$$3 \int \frac{dy}{y} = \int \frac{dz}{z}$$

$$3 \log y = \log z + \log(c_2)$$

$$\log y^3 = \log(c_2 z)$$

$$y^3 = c_2 z$$

$$c_2 = \frac{y^3}{z}$$

$$\frac{dx}{y^2 z} = \frac{dz}{xy^2}$$

$$\frac{dx}{z} = \frac{dz}{x}$$

Integrating

$$\int x dx = \int z dz$$

$$\frac{x^3}{3} = \frac{y^3}{3} + c_1$$

$$x^3 = y^3 + 3c_1$$

$$x^3 - y^3 = k_1$$

$$\frac{x^2}{2} = \frac{z^2}{2} + c_2$$

$$x^2 = z^2 + 2c_2$$

$$x^2 - z^2 = k_2$$

Thus the solution is,  $\varphi(u, v) = 0$

$$\varphi\left((x^3 - y^3), (x^2 - z^2)\right) = 0.$$

6. Solve  $(mz - ny)\frac{\partial z}{\partial x} + (nx - lz)\frac{\partial z}{\partial y} = ly - mx$

**Sol:** Given  $(mz - ny)p + (nx - lz)q = ly - mx$

$$\langle Pp + Qq = R \rangle$$

Here  $P = mz - ny$        $Q = nx - lz$        $R = ly - mx$

Auxiliary equations

$$\frac{dx}{P} = \frac{dy}{Q} = \frac{dz}{R}$$

$$\frac{dx}{(mz-ny)} = \frac{dy}{(nx-lz)} = \frac{dz}{(ly-mx)}$$

Let the multipliers be  $x, y, z$

$$\therefore \text{ Each fraction} = \frac{x dx + y dy + z dz}{x(mz-ny) + y(nx-lz) + z(ly-mx)}$$

$$k = \frac{x dx + y dy + z dz}{x mz - x ny + y nx - y lz + z ly - z mx}$$

$$k = \frac{x dx + y dy + z dz}{0}$$

$$x dx + y dy + z dz = 0$$

Integrate

$$\int x dx + \int y dy + \int z dz = 0$$

$$\frac{x^2}{2} + \frac{y^2}{2} + \frac{z^2}{2} = c_1$$

$$x^2 + y^2 + z^2 = 2c_1$$

$$x^2 + y^2 + z^2 = k_1$$

Let the multipliers be  $l, m, n$

$$\therefore \text{ Each fraction} = \frac{l dx + m dy + n dz}{l(mz-ny) + m(nx-lz) + n(ly-mx)}$$

$$k = \frac{l dx + m dy + n dz}{lmz - lny + mnx - mlz + nly - nmx}$$

$$k = \frac{l dx + m dy + n dz}{0}$$

$$l dx + m dy + n dz = 0$$

Integrate

$$\int l dx + \int m dy + \int n dz = 0$$

$$lx + my + nz = c_2$$

Thus the solution is,  $\varphi(u, v) = 0$

$$\varphi \left( (x^2 + y^2 + z^2), (lx + my + nz) \right) = 0 \quad \text{OR}$$

$$x^2 + y^2 + z^2 = f(lx + my + nz)$$

7. Solve  $x^2(y - z)p + y^2(z - x)q = z^2(x - y)$

**Sol:** Given  $x^2(y - z)p + y^2(z - x)q = z^2(x - y)$

$$\langle Pp + Qq = R \rangle$$

$$\text{Here } P = x^2(y - z) \quad Q = y^2(z - x) \quad R = z^2(x - y)$$

Auxiliary equations

$$\frac{dx}{P} = \frac{dy}{Q} = \frac{dz}{R}$$

$$\frac{dx}{x^2(y-z)} = \frac{dy}{y^2(z-x)} = \frac{dz}{z^2(x-y)}$$

Let the multipliers be  $\frac{1}{x^2}, \frac{1}{y^2}, \frac{1}{z^2}$

$$\therefore \text{ Each fraction} = \frac{\frac{1}{x^2}dx + \frac{1}{y^2}dy + \frac{1}{z^2}dz}{y-z+z-x+x-y}$$

$$k = \frac{\frac{1}{x^2}dx + \frac{1}{y^2}dy + \frac{1}{z^2}dz}{0}$$

$$\frac{1}{x^2}dx + \frac{1}{y^2}dy + \frac{1}{z^2}dz = 0$$

Integrating

$$\int \frac{1}{x^2} dx + \int \frac{1}{y^2} dx + \int \frac{1}{z^2} dx = 0$$

$$-\frac{1}{x} - \frac{1}{y} - \frac{1}{z} = c_1$$

$$\frac{1}{x} + \frac{1}{y} + \frac{1}{z} = -c_1$$

$$\frac{1}{x} + \frac{1}{y} + \frac{1}{z} = k_1$$

Let the multipliers be  $\frac{1}{x}, \frac{1}{y}, \frac{1}{z}$

$$\text{Each fraction} = \frac{\frac{1}{x}dx + \frac{1}{y}dy + \frac{1}{z}dz}{xy - xz + yz - yx + zx - zy}$$

$$k = \frac{\frac{1}{x}dx + \frac{1}{y}dy + \frac{1}{z}dz}{0}$$

$$\frac{1}{x}dx + \frac{1}{y}dy + \frac{1}{z}dz = 0$$

Integrating

$$\int \frac{1}{x}dx + \int \frac{1}{y}dy + \int \frac{1}{z}dz = 0$$

$$\log x + \log y + \log z = \log c_2$$

$$\log(xyz) = \log c_2$$

$$xyz = c_2$$

Thus the solution is,  $\varphi(u, v) = 0$

$$\varphi\left(\left(\frac{1}{x} + \frac{1}{y} + \frac{1}{z}\right), (xyz)\right) = 0 \quad \text{OR} \quad \frac{1}{x} + \frac{1}{y} + \frac{1}{z} = f(xyz)$$

8. Solve  $(x^2 - y^2 - z^2)p + 2xyq = 2xz$

**Sol:** Given  $(x^2 - y^2 - z^2)p + 2xyq = 2xz$

$$\langle Pp + Qq = R \rangle$$

$$\text{Here } P = (x^2 - y^2 - z^2) \quad Q = 2xy \quad R = 2xz$$

Auxiliary equations

$$\frac{dx}{P} = \frac{dy}{Q} = \frac{dz}{R}$$

$$\frac{dx}{(x^2 - y^2 - z^2)} = \frac{dy}{2xy} = \frac{dz}{2xz}$$

Comparing

$$\frac{dy}{2xy} = \frac{dz}{2xz}$$

$$\frac{dy}{y} = \frac{dz}{z}$$

Integrating

$$\int \frac{dy}{y} = \int \frac{dz}{z}$$

$$\log y = \log z + \log(c_1)$$

$$\log y = \log(zc_1)$$

$$y = zc_1$$

$$\frac{y}{z} = c_1$$

Let the multipliers be  $x, y, z$

$$\therefore \text{Each fraction} = \frac{x dx + y dy + z dz}{x(x^2 - y^2 - z^2) + y(2xy) + z(2xz)}$$

$$k = \frac{x dx + y dy + z dz}{x(x^2 - y^2 - z^2 + 2y^2 + 2z^2)}$$

$$k = \frac{x dx + y dy + z dz}{x(x^2 + y^2 + z^2)}$$

Comparing

$$\frac{x dx + y dy + z dz}{x(x^2 + y^2 + z^2)} = \frac{dy}{2xy}$$

$$\frac{x dx + y dy + z dz}{(x^2 + y^2 + z^2)} = \frac{dy}{2y}$$

$$\frac{2x dx + 2y dy + 2z dz}{(x^2 + y^2 + z^2)} = \frac{dy}{y}$$

Integrating

$$\int \frac{2x dx + 2y dy + 2z dz}{(x^2 + y^2 + z^2)} = \int \frac{dy}{y}$$

$$\log(x^2 + y^2 + z^2) = \log y + \log(c_2)$$

$$\log(x^2 + y^2 + z^2) = \log(yc_2)$$

$$(x^2 + y^2 + z^2) = yc_2$$

$$\frac{(x^2 + y^2 + z^2)}{y} = c_2$$

Thus the solution is,  $\varphi(u, v) = 0$

$$\varphi\left(\frac{y}{z}, \left(\frac{x^2 + y^2 + z^2}{y}\right)\right) = 0 \quad \text{OR} \quad \frac{y}{z} = f\left(\frac{x^2 + y^2 + z^2}{y}\right)$$

9. Solve  $(y^2 + z^2)p + x(yq - z) = 0$

**Sol:** Given  $(y^2 + z^2)p + xyq = xz$

$$\langle Pp + Qq = R \rangle$$

$$\text{Here } P = (y^2 + z^2) \quad Q = xy \quad R = xz$$

Auxiliary equations

$$\frac{dx}{P} = \frac{dy}{Q} = \frac{dz}{R}$$

$$\frac{dx}{(y^2 + z^2)} = \frac{dy}{xy} = \frac{dz}{xz}$$

Comparing

$$\frac{dy}{xy} = \frac{dz}{xz}$$

$$\frac{dy}{y} = \frac{dz}{z}$$

Integrating

$$\int \frac{dy}{y} = \int \frac{dz}{z}$$

$$\log y = \log z + \log(c_1)$$

$$\log y = \log(zc_1)$$

$$y = zc_1$$

$$\frac{y}{z} = c_1$$

Let the multipliers be  $x, -y, -z$

$$\therefore \text{Each fraction} = \frac{x dx - y dy - z dz}{x(y^2 + z^2) - y(xy) - z(xz)}$$

$$k = \frac{x dx - y dy - z dz}{x(y^2 + z^2 - y^2 - z^2)}$$

$$k = \frac{x dx - y dy - z dz}{0}$$

$$x dx - y dy - z dz = 0$$

Integrating

$$\int x dx - \int y dy - \int z dz = 0$$

$$\frac{x^2}{2} - \frac{y^2}{2} - \frac{z^2}{2} = c_2$$

$$x^2 - y^2 - z^2 = 2c_2$$

$$x^2 - y^2 - z^2 = k_2$$

Thus the solution is,  $\varphi(u, v) = 0$

$$\varphi\left(\frac{y}{z}, (x^2 - y^2 - z^2)\right) = 0 \quad \text{OR} \quad \frac{y}{z} = f(x^2 - y^2 - z^2)$$

10. Solve  $x(y^2 + z)p - y(x^2 + z)q = z(x^2 - y^2)$

**Sol:** Given  $x(y^2 + z)p - y(x^2 + z)q = z(x^2 - y^2)$

$$\langle Pp + Qq = R \rangle$$

$$\text{Here } P = x(y^2 + z) \quad Q = -y(x^2 + z) \quad R = z(x^2 - y^2)$$

Auxiliary equations

$$\frac{dx}{P} = \frac{dy}{Q} = \frac{dz}{R}$$

$$\frac{dx}{x(y^2+z)} = \frac{dy}{-y(x^2+z)} = \frac{dz}{z(x^2-y^2)}$$

Let the multipliers be  $\frac{1}{x}, \frac{1}{y}, \frac{1}{z}$

$$\text{Each fraction} = \frac{\frac{1}{x}dx + \frac{1}{y}dy + \frac{1}{z}dz}{y^2+z-x^2-z+x^2-y^2}$$

$$k = \frac{\frac{1}{x}dx + \frac{1}{y}dy + \frac{1}{z}dz}{0}$$

$$\frac{1}{x}dx + \frac{1}{y}dy + \frac{1}{z}dz = 0$$

Integrating

$$\int \frac{1}{x}dx + \int \frac{1}{y}dy + \int \frac{1}{z}dz = 0$$

$$\log x + \log y + \log z = \log c_2$$

$$\log(xyz) = \log c_1$$

$$xyz = c_1$$

Let the multipliers be  $x, y, -1$

$$\text{Each fraction} = \frac{xdx + ydy - dz}{x^2y^2 + x^2z - x^2y^2 - y^2z - x^2z + y^2z}$$

$$k = \frac{xdx + ydy - dz}{0}$$

$$xdx + ydy - dz = 0$$

Integrate

$$\int x dx + \int y dy - \int dz = 0$$

$$\frac{x^2}{2} + \frac{y^2}{2} - z = c_2$$

$$x^2 + y^2 - 2z = 2c_2$$

$$x^2 + y^2 - 2z = k_2$$

Thus the solution is,  $\varphi(u, v) = 0$

$$\varphi((xyz), (x^2 + y^2 - 2z)) = 0 \quad \text{OR} \quad xyz = f(x^2 + y^2 - 2z)$$

11. Solve  $x^2 \frac{\partial z}{\partial x} - y^2 \frac{\partial z}{\partial y} = (x - y)z$

Sol: Given  $x^2p - y^2q = (x - y)z$

$$\langle Pp + Qq = R \rangle$$

$$\text{Here } P = x^2 \quad Q = -y^2 \quad R = (x - y)z$$

Auxiliary equations

$$\frac{dx}{P} = \frac{dy}{Q} = \frac{dz}{R}$$

$$\frac{dx}{x^2} = \frac{dy}{-y^2} = \frac{dz}{(x-y)z}$$

Comparing

$$\frac{dx}{x^2} = \frac{dy}{-y^2}$$

Integrating

$$\int \frac{dx}{x^2} = - \int \frac{dy}{y^2}$$

$$-\frac{1}{x} = \frac{1}{y} + c_1$$

$$\frac{1}{x} + \frac{1}{y} = -c_1$$

$$\frac{1}{x} + \frac{1}{y} = k_1$$

Also , we can write

$$\frac{dx+dy}{x^2-y^2} = \frac{dz}{(x-y)z}$$

$$\frac{dx+dy}{(x+y)(x-y)} = \frac{dz}{(x-y)z}$$

$$\frac{dx+dy}{(x+y)} = \frac{dz}{z}$$

Integrating we get

$$\log(x + y) = \log z + \log(c_2)$$

$$\log(x + y) = \log(zc_2)$$

$$(x + y) = zc_2$$

$$\frac{(x+y)}{z} = c_2$$

Thus the solution is,  $\varphi(u, v) = 0$

$$\varphi\left(\left(\frac{1}{x} + \frac{1}{y}\right), \left(\frac{x+y}{z}\right)\right) = 0 \quad \text{OR} \quad \frac{1}{x} + \frac{1}{y} = f\left(\frac{x+y}{z}\right)$$

### Derivation of One dimensional Wave Equation [ $u_{tt} = c^2 u_{xx}$ ]

Consider a flexible string tightly stretched between two fixed points at a distance 'l' apart.

Let ' $\rho$ ' be the mass per unit length. We assume

1. The tension  $T$  of the string is same throughout.
2. The effect of gravity can be ignored due to large tension ' $T$ '.
3. The motion of string is in small transverse vibration.

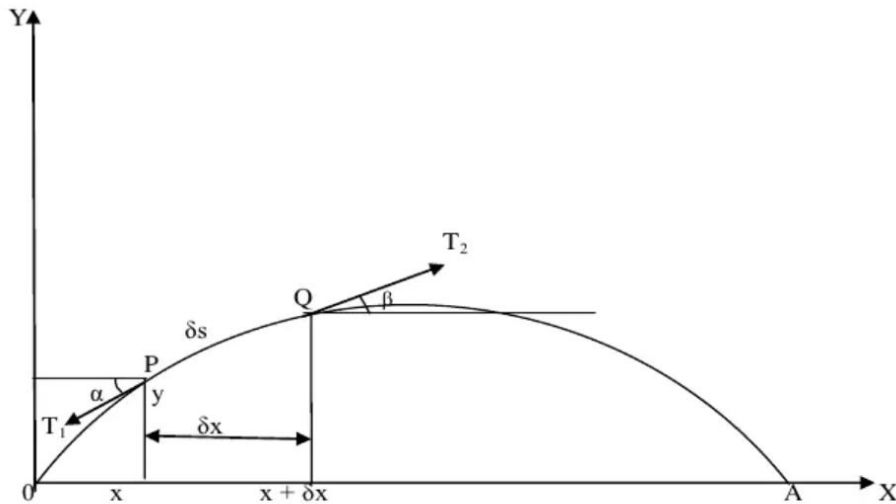

Let us consider the forces acting on a small element PQ of length  $\delta x$ .

Let  $T_1$  and  $T_2$  be the tensions at the points P and Q.

$\therefore T_1 \cos \alpha = T_2 \cos \beta = T$  [ Since there is no motion in horizontal direction ]

$$T_1 \cos \alpha = T \quad , \quad T_2 \cos \beta = T$$

$$\cos \alpha = \frac{T}{T_1} \quad , \quad \cos \beta = \frac{T}{T_2}$$

$$\frac{1}{\cos \alpha} = \frac{T_1}{T} \quad , \quad \frac{1}{\cos \beta} = \frac{T_2}{T} \quad \text{--- (1)}$$

Vertical component of tension are  $-T_1 \sin \alpha$  and  $T_2 \sin \beta$ , where the *-ve sign* is used because  $T_1$  is directed downwards.

Thus, Resultant force  $F = T_2 \sin \beta - T_1 \sin \alpha$

Applying Newton's second law of motion,

$F = \text{mass} * \text{acceleration}$

$$T_2 \sin \beta - T_1 \sin \alpha = \rho \delta x * \frac{\partial^2 u}{\partial t^2} \quad \text{[density=mass/length]}$$

Divide throughout by  $T$

$$\frac{T_2}{T} \sin\beta - \frac{T_1}{T} \sin\alpha = \frac{\rho\delta x}{T} * \frac{\partial^2 u}{\partial t^2}$$

$$\frac{1}{\cos\beta} \cdot \sin\beta - \frac{1}{\cos\alpha} \cdot \sin\alpha = \frac{\rho\delta x}{T} * \frac{\partial^2 u}{\partial t^2} \quad [\text{From (1) }]$$

$$\tan\beta - \tan\alpha = \frac{\rho}{T} \cdot \delta x \cdot \frac{\partial^2 u}{\partial t^2}$$

$$\left(\frac{\partial u}{\partial x}\right)_{x+\delta x} - \left(\frac{\partial u}{\partial x}\right)_x = \frac{\rho}{T} \cdot \delta x \cdot \frac{\partial^2 u}{\partial t^2}$$

$$\frac{\left(\frac{\partial u}{\partial x}\right)_{x+\delta x} - \left(\frac{\partial u}{\partial x}\right)_x}{\delta x} = \frac{\rho}{T} \cdot \frac{\partial^2 u}{\partial t^2}$$

$$\lim_{x \rightarrow 0} \frac{\left(\frac{\partial u}{\partial x}\right)_{x+\delta x} - \left(\frac{\partial u}{\partial x}\right)_x}{\delta x} = \lim_{x \rightarrow 0} \frac{\rho}{T} \cdot \frac{\partial^2 u}{\partial t^2}$$

$$\frac{\partial}{\partial x} \left(\frac{\partial u}{\partial x}\right) = \frac{\rho}{T} \cdot \frac{\partial^2 u}{\partial t^2}$$

$$\frac{\partial^2 u}{\partial x^2} = \frac{\rho}{T} \cdot \frac{\partial^2 u}{\partial t^2}$$

$$\frac{\partial^2 u}{\partial t^2} = \frac{T}{\rho} \cdot \frac{\partial^2 u}{\partial x^2}$$

$$\frac{\partial^2 u}{\partial t^2} = c^2 \frac{\partial^2 u}{\partial x^2} \quad \left[ c^2 = \frac{T}{\rho} \right]$$

OR

$$u_{tt} = c^2 u_{xx}$$

### Derivation of One dimensional Heat Equation [ $u_t = c^2 u_{xx}$ ]

Consider a homogeneous bar of uniform cross section  $A$ . Suppose that the sides are covered with a material impervious to heat so that streamlines of heat-flow are all parallel and perpendicular to area. Take one end of the bar as the origin and the direction of flow as the positive  $x$ -axis.

Let  $u = u(x, t)$  be the temperature of the slab at a distance  $x$  from the origin. Consider an element of slab between the plane  $PQRS$  and  $ABCD$  at a distance  $x$  and  $x + \delta x$  from the end  $O$ . Let  $\rho$  be the density,  $s$  the specific heat and  $k$  the thermal conductivity.

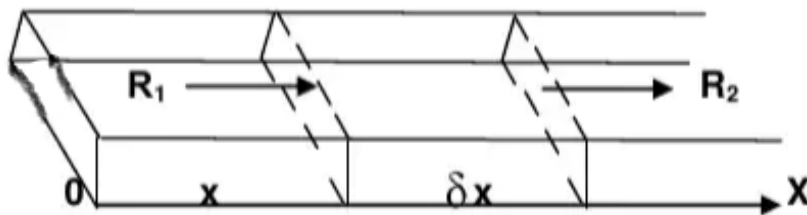

Let  $\delta u$  be the change in temperature in a slab of thickness  $\delta x$  of the bar.

The mass of the element =  $A\rho\delta x$

The quantity of heat stored in the slab element =  $A\rho s\delta x\delta u$

∴ Rate of increase of heat in this slab element is  $R = (A\rho s\delta x) \frac{\partial u}{\partial t}$

Let  $R_1$  be the rate of inflow of heat and  $R_2$  is the outflow of heat.

We have,  $R_1 = -kA \left[ \frac{\partial u}{\partial x} \right]_x$  ,  $R_2 = -kA \left[ \frac{\partial u}{\partial x} \right]_{x+\delta x}$

The negative sign is due to decrease in temperature as increase in  $t$

Thus,  $R = R_1 - R_2$

$$(A\rho s\delta x) \frac{\partial u}{\partial t} = -kA \left[ \frac{\partial u}{\partial x} \right]_x + kA \left[ \frac{\partial u}{\partial x} \right]_{x+\delta x}$$

$$(A\rho s\delta x) \frac{\partial u}{\partial t} = kA \left[ \left[ \frac{\partial u}{\partial x} \right]_{x+\delta x} - \left[ \frac{\partial u}{\partial x} \right]_x \right] \quad [ \text{Divide by } A ]$$

$$\rho s \frac{\partial u}{\partial t} = k \frac{\left[ \left[ \frac{\partial u}{\partial x} \right]_{x+\delta x} - \left[ \frac{\partial u}{\partial x} \right]_x \right]}{\delta x}$$

$$\lim_{x \rightarrow 0} \rho s \frac{\partial u}{\partial t} = \lim_{x \rightarrow 0} k \frac{\left[ \left[ \frac{\partial u}{\partial x} \right]_{x+\delta x} - \left[ \frac{\partial u}{\partial x} \right]_x \right]}{\delta x}$$

$$\rho s \frac{\partial u}{\partial t} = k \frac{\partial}{\partial x} \left( \frac{\partial u}{\partial x} \right)$$

$$\frac{\partial u}{\partial t} = \frac{k}{\rho s} \frac{\partial^2 u}{\partial x^2}$$

$$\frac{\partial u}{\partial t} = c^2 \frac{\partial^2 u}{\partial x^2} \quad \left[ c^2 = \frac{k}{\rho s} \right]$$

OR

$$u_t = c^2 u_{xx}$$

*Various possible solutions of the one dimensional wave equation  $[u_{tt} = c^2 u_{xx}]$  by method of separation of variables*

Consider,  $u_{tt} = c^2 u_{xx}$

$$\frac{\partial^2 u}{\partial t^2} = c^2 \frac{\partial^2 u}{\partial x^2}$$

Let  $u = XT$  --- (\*) where  $X = X(x)$  ,  $T = T(t)$  be the solution of above equation.

$$\frac{\partial^2(XT)}{\partial t^2} = c^2 \frac{\partial^2(XT)}{\partial x^2}$$

$$X \frac{\partial^2 T}{\partial t^2} = c^2 T \frac{\partial^2 X}{\partial x^2}$$

Divide by  $XTc^2$ , we have

$$\frac{1}{c^2 T} \frac{\partial^2 T}{\partial t^2} = \frac{1}{X} \frac{\partial^2 X}{\partial x^2} = k (\text{Say})$$

$$\frac{1}{X} \frac{\partial^2 X}{\partial x^2} = k$$

$$\frac{\partial^2 X}{\partial x^2} = kX$$

$$\frac{\partial^2 X}{\partial x^2} - kX = 0$$

$$(D^2 - k)X = 0$$

A.E :

$$m^2 - k = 0$$

$$m^2 = k \text{ --- (1)}$$

$$\frac{1}{c^2 T} \frac{\partial^2 T}{\partial t^2} = k$$

$$\frac{\partial^2 T}{\partial t^2} = kc^2 T$$

$$\frac{\partial^2 T}{\partial t^2} - kc^2 T = 0$$

$$(D^2 - kc^2)T = 0$$

$$m^2 - kc^2 = 0$$

$$m^2 = kc^2 \text{ --- (2)}$$

**Case-1:** When  $k = p^2$ ,  $k$  is positive

$$(1) \Rightarrow m^2 = p^2$$

$$m = \pm p$$

$$m = p, -p$$

$$(2) \Rightarrow m^2 = p^2 c^2$$

$$m = \pm pc$$

$$m = pc, -pc$$

The solution is,

$$X = X_c$$

$$X = c_1 e^{px} + c_2 e^{-px}$$

$$T = T_c$$

$$T = c'_1 e^{pct} + c'_2 e^{-pct}$$

$\therefore (*) \Rightarrow u = XT = [c_1 e^{px} + c_2 e^{-px}][c'_1 e^{pct} + c'_2 e^{-pct}]$ , is the solution of PDE.

**Case-2:** When  $k = -p^2$ ,  $k$  is negative

$$(1) \Rightarrow m^2 = -p^2$$

$$m = \pm pi$$

$$(2) \Rightarrow m^2 = -p^2 c^2$$

$$m = \pm pci$$

The solution is,

$$X = X_c$$

$$X = c_3 \cos px + c_4 \sin px$$

$$T = T_c$$

$$T = c'_3 \cos(pct) + c'_4 \sin(pct)$$

$\therefore (*) \Rightarrow u = XT = [c_3 \cos px + c_4 \sin px][c'_3 \cos(pct) + c'_4 \sin(pct)]$ , is the solution of PDE.

**Case-3:** When  $k = 0$

$$(1) \Rightarrow m^2 = 0$$

$$m = 0, 0$$

$$(2) \Rightarrow m^2 = 0$$

$$m = 0, 0$$

The solution is,

$$X = X_c \qquad T = T_c$$

$$X = c_5 + c_6 x \qquad T = c'_5 + c'_6 t$$

$\therefore (*) \Rightarrow u = XT = [c_5 + c_6 x][c'_5 + c'_6 t]$ , is the solution of PDE.

*Various possible solutions of the one dimensional Heat equation  $[u_t = c^2 u_{xx}]$  by method of separation of variables*

Consider,  $u_t = c^2 u_{xx}$

$$\frac{\partial u}{\partial t} = c^2 \frac{\partial^2 u}{\partial x^2}$$

Let  $u = XT$  --- (\*) where  $X = X(x)$ ,  $T = T(t)$  be the solution of above equation.

$$\frac{\partial(XT)}{\partial t} = c^2 \frac{\partial^2(XT)}{\partial x^2}$$

$$X \frac{\partial T}{\partial t} = c^2 T \frac{\partial^2 X}{\partial x^2}$$

Divide by  $XTc^2$ , we have

$$\frac{1}{c^2 T} \frac{\partial T}{\partial t} = \frac{1}{X} \frac{\partial^2 X}{\partial x^2} = k(\text{Say})$$

$$\frac{1}{X} \frac{\partial^2 X}{\partial x^2} = k$$

$$\frac{1}{c^2 T} \frac{\partial T}{\partial t} = k$$

$$\frac{\partial^2 X}{\partial x^2} = kX$$

$$\frac{\partial T}{\partial t} = kc^2 T$$

$$\frac{\partial^2 X}{\partial x^2} - kX = 0$$

$$\frac{\partial T}{\partial t} - kc^2 T = 0$$

$$(D^2 - k)X = 0$$

$$(D - kc^2)T = 0$$

A.E :

$$m^2 - k = 0$$

$$m - kc^2 = 0$$

$$m^2 = k \text{ --- (1)}$$

$$m = kc^2 \text{ --- (2)}$$

**Case-1:** When  $k = p^2$ ,  $k$  is positive

$$(1) \Rightarrow m^2 = p^2$$

$$(2) \Rightarrow m = p^2 c^2$$

$$m = \pm p$$

$$m = p^2 c^2$$

$$m = p, -p$$

The solution is,

$$X = X_c \qquad T = T_c$$

$$X = c_1 e^{px} + c_2 e^{-px} \qquad T = c'_1 e^{p^2 c^2 t}$$

$\therefore (*) \Rightarrow u = XT = [c_1 e^{px} + c_2 e^{-px}] [c'_1 e^{p^2 c^2 t}]$ , is the solution of PDE.

**Case-2:** When  $k = -p^2$ ,  $k$  is negative

$$(1) \Rightarrow m^2 = -p^2$$

$$m = \pm pi$$

$$(2) \Rightarrow m = -p^2 c^2$$

$$m = -p^2 c^2$$

The solution is,

$$X = X_c$$

$$T = T_c$$

$$X = c_3 \cos px + c_4 \sin px$$

$$T = c'_3 e^{-p^2 c^2 t}$$

$\therefore (*) \Rightarrow u = XT = [c_3 \cos px + c_4 \sin px] [c'_3 e^{-p^2 c^2 t}]$ , is the solution of PDE.

**Case-3:** When  $k = 0$

$$(1) \Rightarrow m^2 = 0$$

$$m = 0, 0$$

$$(2) \Rightarrow m = 0$$

$$m = 0$$

The solution is,

$$X = X_c$$

$$T = T_c$$

$$X = c_5 + c_6 x$$

$$T = c'_5$$

$\therefore (*) \Rightarrow u = XT = [c_5 + c_6 x] [c'_5]$ , is the solution of PDE.

## MODULE-4

### NUMERICAL METHODS -I

Numerical method provides various technique to find approximate solution to different problem using simple operation.

#### *Numerical Solution of Polynomial and Transcendental Equations*

Given an equation  $f(x) = 0$  it is generally not possible to find roots ' $x$ ' such that  $f(x)$  becomes zero exactly. We discuss two numerical methods for the solution of algebraic and transcendental equation.

Equation involving algebraic quantity like  $x, x^2, x^3, \dots$  are called **algebraic equation**.

**Eg:**  $x^3 - 3x - 4 = 0$  ,  $x^4 + x^3 = 80$

Equation involving non algebraic quantity like  $e^x, \log x, \sin x, \tan x, \dots$  are called **transcendental equation**.

**Eg:**  $xe^x - 2 = 0$  ,  $x \log x - 1.2 = 0$ ,  $\tan x = 2x$

Numerical methods are often a repetitive nature. This consist repeated execution of the same process where at each step to result of the previous step is used. This is known as iterative process.

We discuss two numerical methods

1. Regula-Falsi method
2. Newton-Raphson method

#### **Regula-Falsi method (or) Method of False position**

**Formula:**

$$x_n = \frac{af(b)-bf(a)}{f(b)-f(a)}$$

#### **Problems**

1. Using the method of false position find the real root correct to 3 decimal places of the equation  $x^3 + 5x - 11 = 0$ .

**Sol:** Given  $f(x) = x^3 + 5x - 11$

$$f(0) = -11$$

$$f(1) = -5 < 0$$

$$f(2) = 7 > 0$$

The root lies between (1,2).

Wkt,

$$x_n = \frac{af(b)-bf(a)}{f(b)-f(a)}$$

**Step-1:**       $a = 1$                        $b = 2$   
                   $f(a) = -5$                      $f(b) = 7$

$$x_1 = \frac{1(7)-2(-5)}{(7)-(-5)}$$

$$x_1 = \frac{7+10}{7+5}$$

$$x_1 = \mathbf{1.417}$$

$$f(1.417) = -1.070 < 0$$

$$f(2) = 7 > 0$$

The root lies between (1.417,2).

**Step-2:**       $a = 1.417$                        $b = 2$   
                   $f(a) = -1.070$                      $f(b) = 7$

$$x_2 = \frac{(1.417)(7)-2(-1.070)}{(7)-(-1.070)}$$

$$x_2 = \mathbf{1.494}$$

$$f(1.494) = -0.195 < 0$$

$$f(2) = 7 > 0$$

The root lies between (1.417,2).

**Step-3:**       $a = 1.494$                        $b = 2$   
                   $f(a) = -0.195$                      $f(b) = 7$

$$x_3 = \frac{(1.494)(7)-2(-0.195)}{(7)-(-0.195)}$$

$$x_3 = \mathbf{1.508}$$

$$f(1.508) = -0.031 < 0$$

$$f(2) = 7 > 0$$

The root lies between (1.508,2).

**Step-4:**       $a = 1.508$                        $b = 2$   
                   $f(a) = -0.031$                      $f(b) = 7$

$$x_4 = \frac{(1.508)(7)-2(-0.031)}{(7)-(-0.031)}$$

$$x_4 = \mathbf{1.510}$$

$$f(1.510) = -0.007 < 0$$

$$f(2) = 7 > 0$$

The root lies between (1.510,2).

$$\begin{array}{ll} \text{Step-5:} & a = 1.510 & b = 2 \\ & f(a) = -0.007 & f(b) = 7 \end{array}$$

$$x_5 = \frac{(1.510)(7) - 2(-0.007)}{(7) - (-0.007)}$$

$$x_5 = \mathbf{1.510}$$

∴ The real root is 1.510

2. Using the method of false position find the real root correct to 3 decimal places of the equation  $x^3 - 5x - 7 = 0$ .

$$\text{Sol: Given } f(x) = x^3 - 5x - 7$$

$$f(0) = -7$$

$$f(1) = -1$$

$$f(2) = -9 < 0$$

$$f(3) = 5 > 0$$

The root lies between (2,3).

Wkt,

$$x_n = \frac{af(b) - bf(a)}{f(b) - f(a)}$$

$$\begin{array}{ll} \text{Step-1:} & a = 2 & b = 3 \\ & f(a) = -9 & f(b) = 5 \end{array}$$

$$x_1 = \frac{2(5) - 3(-9)}{(5) - (-9)}$$

$$x_1 = \mathbf{2.643}$$

$$f(2.643) = -1.752 < 0$$

$$f(3) = 5 > 0$$

The root lies between (2.643,3).

$$\begin{array}{ll} \text{Step-2:} & a = 2.643 & b = 3 \\ & f(a) = -1.752 & f(b) = 5 \end{array}$$

$$x_2 = \frac{(2.643)(5) - 3(-1.752)}{(5) - (-1.752)}$$

$$x_2 = \mathbf{2.736}$$

$$f(2.736) = -0.199 < 0$$

$$f(3) = 5 > 0$$

The root lies between (2.736,3).

$$\begin{array}{ll} \text{Step-3:} & a = 2.736 & b = 3 \\ & f(a) = -0.199 & f(b) = 5 \end{array}$$

$$x_3 = \frac{(2.736)(5) - 3(-0.199)}{(5) - (-0.199)}$$

$$x_3 = 2.746$$

$$f(2.746) = -0.024 < 0$$

$$f(3) = 5 > 0$$

The root lies between (2.746,3).

$$\begin{array}{ll} \text{Step-4:} & a = 2.746 & b = 3 \\ & f(a) = -0.024 & f(b) = 5 \end{array}$$

$$x_4 = \frac{(2.746)(5) - 3(-0.024)}{(5) - (-0.024)}$$

$$x_4 = 2.747$$

$$f(2.747) = -0.006 < 0$$

$$f(3) = 5 > 0$$

The root lies between (2.747,3).

$$\begin{array}{ll} \text{Step-5:} & a = 2.747 & b = 3 \\ & f(a) = -0.006 & f(b) = 5 \end{array}$$

$$x_5 = \frac{(2.747)(5) - 3(-0.006)}{(5) - (-0.006)}$$

$$x_5 = 2.747$$

∴ The real root is 2.747.

3. Find the real root of the equation  $x \log_{10} x = 1.2$  by Regula falsi method.

Carry out 3 iterations.

$$\text{Sol: Given } f(x) = x \log_{10} x - 1.2$$

$$f(1) = -1.2 < 0$$

$$f(2) = -0.5979 < 0$$

$$f(3) = 0.2314 > 0$$

The root lies between (2,3).

Wkt,

$$x_n = \frac{af(b)-bf(a)}{f(b)-f(a)}$$

**Step-1:**      $a = 2$                        $b = 3$   
                   $f(a) = -0.5979$          $f(b) = 0.2314$

$$x_1 = \frac{2(0.2314)-3(-0.5979)}{(0.2314)-(-0.5979)}$$

$$x_1 = 2.7210$$

$$f(2.7210) = -0.0171 < 0$$

$$f(3) = 0.2314 > 0$$

The root lies between (2.7210,3).

**Step-2:**      $a = 2.7210$                  $b = 3$   
                   $f(a) = -0.0171$          $f(b) = 0.2314$

$$x_2 = \frac{(2.7210)(0.2314)-3(-0.0171)}{(0.2314)-(-0.0171)}$$

$$x_2 = 2.7402$$

$$f(2.7402) = -0.0004 < 0$$

$$f(3) = 0.2314 > 0$$

The root lies between (2.7402,3).

**Step-3:**      $a = 2.7402$                  $b = 3$   
                   $f(a) = -0.0004$          $f(b) = 0.2314$

$$x_3 = \frac{(2.7402)(0.2314)-3(-0.0004)}{(0.2314)-(-0.0004)}$$

$$x_3 = 2.7406$$

∴ The real root is 2.7406.

4. Find the real root of the equation  $\cos x = 3x - 1$  upto 3 decimal places using RF method.

**Sol:** Given  $f(x) = \cos x - 3x + 1$

$$f(0) = 2 > 0$$

$$f(1) = -1.460 < 0$$

The root lies between (0,1).

Wkt,

$$x_n = \frac{af(b)-bf(a)}{f(b)-f(a)}$$

**Step-1:**      $a = 0$                        $b = 1$   
                   $f(a) = 2$                      $f(b) = -1.460$

$$x_1 = \frac{0(-1.460)-1(2)}{(-1.460)-(2)}$$

$$x_1 = 0.578$$

$$f(0.578) = 0.104 > 0$$

$$f(1) = -1.460 < 0$$

The root lies between (0.578,1).

$$\text{Step-2: } \quad a = 0.578 \quad b = 1$$

$$f(a) = 0.104 \quad f(b) = -1.460$$

$$x_2 = \frac{(0.578)(-1.460)-1(0.104)}{(-1.460)-(0.104)}$$

$$x_2 = 0.606$$

$$f(0.606) = 0.004 > 0$$

$$f(1) = -1.460 < 0$$

The root lies between (0.606,1).

$$\text{Step-3: } \quad a = 0.606 \quad b = 1$$

$$f(a) = 0.004 \quad f(b) = -1.460$$

$$x_3 = \frac{(0.606)(-1.460)-1(0.004)}{(-1.460)-(0.004)}$$

$$x_3 = 0.607$$

$$f(0.607) = 0$$

∴ The real root is 0.607.

5. Find the real root of the equation  $xe^x = 2$  upto three decimal places using RF method. Carryout 4 iterations.

**Sol:** Given  $f(x) = xe^x - 2$

$$f(0) = -2 < 0$$

$$f(1) = 0.718 > 0$$

The root lies between (0,1).

Wkt,

$$x_n = \frac{af(b)-bf(a)}{f(b)-f(a)}$$

$$\text{Step-1: } \quad a = 0 \quad b = 1$$

$$f(a) = -2 \quad f(b) = 0.718$$

$$x_1 = \frac{0(0.718)-1(-2)}{(0.718)-(-2)}$$

$$x_1 = 0.736$$

$$f(0.736) = -0.464 < 0$$

$$f(1) = 0.718 > 0$$

The root lies between (0.736,1).

**Step-2:**  $a = 0.736$

$$b = 1$$

$$f(a) = -0.464$$

$$f(b) = 0.718$$

$$x_2 = \frac{(0.736)(0.718) - 1(-0.464)}{(0.718) - (-0.464)}$$

$$x_2 = \mathbf{0.840}$$

$$f(0.840) = -0.054 < 0$$

$$f(1) = 0.718 > 0$$

The root lies between (0.840,1).

**Step-3:**  $a = 0.840$

$$b = 1$$

$$f(a) = -0.054$$

$$f(b) = 0.718$$

$$x_3 = \frac{(0.840)(0.718) - 1(-0.054)}{(0.718) - (-0.054)}$$

$$x_3 = \mathbf{0.851}$$

$$f(0.851) = -0.007 < 0$$

$$f(1) = 0.718 > 0$$

The root lies between (0.851,1).

**Step-4:**  $a = 0.851$

$$b = 1$$

$$f(a) = -0.007$$

$$f(b) = 0.718$$

$$x_4 = \frac{(0.851)(0.718) - 1(-0.007)}{(0.718) - (-0.007)}$$

$$x_4 = \mathbf{0.852}$$

$\therefore$  The real root is 0.852.

6. Find the real root of the equation  $xe^x - \cos x = 0$  using RF method.

**Sol:** Given  $f(x) = xe^x - \cos x$

$$f(0) = -1 < 0$$

$$f(1) = 2.1780 > 0$$

The root lies between (0,1).

Wkt,

$$x_n = \frac{af(b) - bf(a)}{f(b) - f(a)}$$

**Step-1:**  $a = 0$

$$b = 1$$

$$f(a) = -1$$

$$f(b) = 2.1780$$

$$x_1 = \frac{0(2.1780) - 1(-1)}{(2.1780) - (-1)}$$

$$x_1 = \mathbf{0.3147}$$

$$f(0.3147) = -0.5198 < 0$$

$$f(1) = 2.1780 > 0$$

The root lies between (0.3147,1).

**Step-2:**  $a = 0.3147$

$$b = 1$$

$$f(a) = -0.5198$$

$$f(b) = 2.1780$$

$$x_2 = \frac{(0.3147)(2.1780) - 1(-0.5198)}{(2.1780) - (-0.5198)}$$

$$x_2 = \mathbf{0.4467}$$

$$f(0.4467) = -0.2036 < 0$$

$$f(1) = 2.1780 > 0$$

The root lies between (0.4467,1).

$$\text{Step-3: } a = 0.4467$$

$$b = 1$$

$$f(a) = -0.2036$$

$$f(b) = 2.1780$$

$$x_3 = \frac{(0.4467)(2.1780) - 1(-0.2036)}{(2.1780) - (-0.2036)}$$

$$x_3 = \mathbf{0.4940}$$

$$f(0.4940) = -0.0708 < 0$$

$$f(1) = 2.1780 > 0$$

The root lies between (0.4940,1).

$$\text{Step-4: } a = 0.4940$$

$$b = 1$$

$$f(a) = -0.0708$$

$$f(b) = 2.1780$$

$$x_4 = \frac{(0.4940)(2.1780) - 1(-0.0708)}{(2.1780) - (-0.0708)}$$

$$x_4 = \mathbf{0.5099}$$

$$f(0.5099) = -0.0237 < 0$$

$$f(1) = 2.1780 > 0$$

The root lies between (0.5099,1).

$$\text{Step-5: } a = 0.5099$$

$$b = 1$$

$$f(a) = -0.0237$$

$$f(b) = 2.1780$$

$$x_5 = \frac{(0.5099)(2.1780) - 1(-0.0237)}{(2.1780) - (-0.0237)}$$

$$x_5 = \mathbf{0.5152}$$

$$f(0.5152) = -0.0078 < 0$$

$$f(1) = 2.1780 > 0$$

The root lies between (0.5152,1).

$$\text{Step-6: } a = 0.5152$$

$$b = 1$$

$$f(a) = -0.0078$$

$$f(b) = 2.1780$$

$$x_6 = \frac{(0.5152)(2.1780) - 1(-0.0078)}{(2.1780) - (-0.0078)}$$

$$x_6 = \mathbf{0.5169}$$

$$f(0.5169) = -0.0026 < 0$$

$$f(1) = 2.1780 > 0$$

The root lies between (0.5169,1).

$$\text{Step-7: } a = 0.5169$$

$$b = 1$$

$$f(a) = -0.0026$$

$$f(b) = 2.1780$$

$$x_7 = \frac{(0.5169)(2.1780) - 1(-0.0026)}{(2.1780) - (-0.0026)}$$

$$x_7 = \mathbf{0.5175}$$

$$f(0.5175) = -0.0008 < 0$$

$$f(1) = 2.1780 > 0$$

The root lies between (0.5175,1).

$$\text{Step-8: } a = 0.5175$$

$$b = 1$$

$$f(a) = -0.0008$$

$$f(b) = 2.1780$$

$$x_8 = \frac{(0.5175)(2.1780) - 1(-0.0008)}{(2.1780) - (-0.0008)}$$

$$x_8 = \mathbf{0.5177}$$

$$f(0.5177) = -0.0002 < 0$$

$$f(1) = 2.1780 > 0$$

The root lies between (0.5177,1).

$$\text{Step-9: } a = 0.5177$$

$$b = 1$$

$$f(a) = -0.0002$$

$$f(b) = 2.1780$$

$$x_9 = \frac{(0.5177)(2.1780) - 1(-0.0002)}{(2.1780) - (-0.0002)}$$

$$x_9 = \mathbf{0.5177}$$

∴ The real root is 0.5177.

7. Use RF method to find the real root of the equation  $\tan x + \tanh x = 0$ , the root lies between 2 & 3. Carryout 3 iteration.

**Sol:** Given  $f(x) = \tan x + \tanh x$

$$f(2) = -1.2210 < 0$$

$$f(3) = 0.8525 > 0$$

The root lies between (2,3).

Wkt,

$$x_n = \frac{af(b) - bf(a)}{f(b) - f(a)}$$

$$\text{Step-1: } a = 2$$

$$b = 3$$

$$f(a) = -1.2210$$

$$f(b) = 0.8525$$

$$x_1 = \frac{2(0.8525) - 3(-1.2210)}{(0.8525) - (-1.2210)}$$

$$x_1 = \mathbf{2.5889}$$

$$f(2.5889) = 0.3720 > 0$$

$$f(2) = -1.2210 < 0$$

The root lies between (2,2.5889).

$$\text{Step-2: } a = 2$$

$$b = 2.5889$$

$$f(a) = -1.2210$$

$$f(b) = 0.3720$$

$$x_2 = \frac{2(0.3720) - (2.5889)(-1.2210)}{(0.3720) - (-1.2210)}$$

$$x_2 = 2.4514$$

$$f(2.4514) = 0.1596 > 0$$

$$f(2) = -1.2210 < 0$$

The root lies between (2, 2.4514).

$$\text{Step-3: } a = 2$$

$$b = 2.4514$$

$$f(a) = -1.2210$$

$$f(b) = 0.1596$$

$$x_3 = \frac{2(0.1596) - (2.4514)(-1.2210)}{(0.1596) - (-1.2210)}$$

$$x_3 = 2.3992$$

∴ The real root is 2.3992.

8. Find the real root of the equation  $x^3 - 3x + 4 = 0$  using RF method. Carry out 3 iterations.

$$\text{Sol: Given } f(x) = x^3 - 3x + 4$$

$$f(0) = 4$$

$$f(1) = 2$$

$$f(2) = 6$$

$$f(3) = 22$$

$$f(-1) = 6$$

$$f(-2) = 2 > 0$$

$$f(-3) = -14 < 0$$

The root lies between (-3, -2).

Wkt,

$$x_n = \frac{af(b) - bf(a)}{f(b) - f(a)}$$

$$\text{Step-1: } a = -3$$

$$b = -2$$

$$f(a) = -14$$

$$f(b) = 2$$

$$x_1 = \frac{(-3)(2) - (-2)(-14)}{(2) - (-14)}$$

$$x_1 = -2.1250$$

$$f(-2.1250) = 0.7793 > 0$$

$$f(-3) = -14 < 0$$

The root lies between (-3, -2.1250).

$$\text{Step-2: } a = -3$$

$$b = -2.1250$$

$$f(a) = -14$$

$$f(b) = 0.7793$$

$$x_2 = \frac{(-3)(0.7793) - (-2.1250)(-14)}{(0.7793) - (-14)}$$

$$x_2 = -2.1711$$

$$f(-2.1711) = 0.2794 > 0$$

$$f(-3) = -14 < 0$$

The root lies between (-3, -2.1711).

$$\text{Step-3: } a = -3$$

$$b = -2.1711$$

$$f(a) = -14$$

$$f(b) = 0.2794$$

$$x_3 = \frac{(-3)(0.2794) - (-2.1711)(-14)}{(0.2794) - (-14)}$$

$$x_3 = -2.1873$$

∴ The real root is -2.1873.

### Newton-Raphson Method

**Formula:**

$$x_{n+1} = x_n - \frac{f(x_n)}{f'(x_n)} ; f'(x_n) \neq 0 , n = 0,1,2,3, \dots$$

$$n = 0 , x_1 = x_0 - \frac{f(x_0)}{f'(x_0)} ; f'(x_0) \neq 0$$

$$n = 1 , x_2 = x_1 - \frac{f(x_1)}{f'(x_1)} ; f'(x_1) \neq 0 \quad \text{and so on.}$$

### Problems

1. Use NR method to find the real root of the equation  $x^3 - 3x - 5 = 0$  , correct to 3 decimal places.

**Sol:** Given  $f(x) = x^3 - 3x - 5$

$$f(0) = -5$$

$$f(1) = -7$$

$$f(2) = -3$$

$$f(3) = 13$$

The root lies between (2,3).

Since  $f(2)$  lies nearer to 0.

Let  $x_0 = 2$

We know that  $x_{n+1} = x_n - \frac{f(x_n)}{f'(x_n)}$

Here  $f(x) = x^3 - 3x - 5$

$$f'(x) = 3x^2 - 3$$

**Step 1:**  $x_1 = x_0 - \frac{f(x_0)}{f'(x_0)}$

$$x_1 = 2 - \frac{f(2)}{f'(2)}$$

$$x_1 = 2 - \frac{(-3)}{(9)}$$

$$x_1 = 2.333$$

**Step 2:**  $x_2 = x_1 - \frac{f(x_1)}{f'(x_1)}$

$$x_2 = 2.333 - \frac{f(2.333)}{f'(2.333)}$$

$$x_2 = 2.333 - \frac{(0.699)}{(13.329)}$$

$$x_2 = 2.281$$

**Step 3:**  $x_3 = x_2 - \frac{f(x_2)}{f'(x_2)}$

$$x_3 = 2.281 - \frac{f(2.281)}{f'(2.281)}$$

$$x_3 = 2.281 - \frac{(0.025)}{(12.609)}$$

$$\mathbf{x_3 = 2.279}$$

$$\text{Step 4: } x_4 = x_3 - \frac{f(x_3)}{f'(x_3)}$$

$$x_4 = 2.279 - \frac{f(2.279)}{f'(2.279)}$$

$$x_4 = 2.279 - \frac{(0)}{(12.582)}$$

$$\mathbf{x_4 = 2.279}$$

∴ The real root is 2.279.

2. Find the real root of the equation  $x^3 + x^2 + 3x + 4 = 0$  applying NR method.

**Sol:** Given  $f(x) = x^3 + x^2 + 3x + 4$

$$f(0) = 4$$

$$f(1) = 11$$

$$f(-1) = 1 > 0$$

$$f(-2) = -6 < 0$$

The root lies between  $(-2, -1)$ .

Since  $f(-1)$  lies nearer to 0.

Let  $x_0 = -1$

We know that  $x_{n+1} = x_n - \frac{f(x_n)}{f'(x_n)}$

Here  $f(x) = x^3 + x^2 + 3x + 4$

$$f'(x) = 3x^2 + 2x + 3$$

$$\text{Step 1: } x_1 = x_0 - \frac{f(x_0)}{f'(x_0)}$$

$$x_1 = (-1) - \frac{f(-1)}{f'(-1)}$$

$$x_1 = (-1) - \frac{(1)}{(4)}$$

$$\mathbf{x_1 = -1.2500}$$

$$\text{Step 2: } x_2 = x_1 - \frac{f(x_1)}{f'(x_1)}$$

$$x_2 = -1.25 - \frac{f(-1.25)}{f'(-1.25)}$$

$$x_2 = -1.25 - \frac{(-0.1406)}{(5.1875)}$$

$$\mathbf{x_2 = -1.2229}$$

$$\text{Step 3: } x_3 = x_2 - \frac{f(x_2)}{f'(x_2)}$$

$$x_3 = -1.2229 - \frac{f(-1.2229)}{f'(-1.2229)}$$

$$x_3 = -1.2229 - \frac{(-0.0020)}{(5.0407)}$$

$$\mathbf{x_3 = -1.2225}$$

$$\text{Step 4: } x_4 = x_3 - \frac{f(x_3)}{f'(x_3)}$$

$$x_4 = -1.2225 - \frac{f(-1.2225)}{f'(-1.2225)}$$

$$x_4 = -1.2225 - \frac{(0)}{(5.0385)}$$

$$\mathbf{x_4 = -1.2225}$$

∴ The real root is  $-1.2225$ .

3. Use NR method to find the real root of  $x \sin x + \cos x = 0$  near  $x = \pi$ . Carry out the iteration upto 4 decimal places of accuracy.

**Sol:** Given  $f(x) = x \sin x + \cos x$

Let  $x_0 = \pi$

We know that  $x_{n+1} = x_n - \frac{f(x_n)}{f'(x_n)}$

Here  $f(x) = x \sin x + \cos x$

$$f'(x) = x \cos x + \sin x - \sin x$$

$$f'(x) = x \cos x$$

**Step 1:**  $x_1 = x_0 - \frac{f(x_0)}{f'(x_0)}$

$$x_1 = (\pi) - \frac{f(\pi)}{f'(\pi)}$$

$$x_1 = (\pi) - \frac{(-1)}{(-\pi)}$$

$$x_1 = \mathbf{2.8233}$$

**Step 2:**  $x_2 = x_1 - \frac{f(x_1)}{f'(x_1)}$

$$x_2 = 2.8233 - \frac{f(2.8233)}{f'(2.8233)}$$

$$x_2 = 2.8233 - \frac{(-0.0662)}{(-2.6815)}$$

$$x_2 = \mathbf{2.7986}$$

**Step 3:**  $x_3 = x_2 - \frac{f(x_2)}{f'(x_2)}$

$$x_3 = 2.7986 - \frac{f(2.7986)}{f'(2.7986)}$$

$$x_3 = 2.7986 - \frac{(-0.0006)}{(-2.6356)}$$

$$x_3 = \mathbf{2.7984}$$

**Step 4:**  $x_4 = x_3 - \frac{f(x_3)}{f'(x_3)}$

$$x_4 = 2.7984 - \frac{f(2.7984)}{f'(2.7984)}$$

$$x_4 = 2.7984 - \frac{(0)}{(-2.6352)}$$

$$x_4 = \mathbf{2.7984}$$

∴ The real root is  $2.7984$ .

4. Use NR method to find the real root of the equation  $xe^x = 2$ , correct to 3 decimal places.

**Sol:** Given  $f(x) = xe^x - 2$

$$f(0) = -2 < 0$$

$$f(1) = 0.718 > 0$$

The root lies between  $(0,1)$ .

Since  $f(1)$  lies nearer to 0.

Let  $x_0 = 1$

We know that  $x_{n+1} = x_n - \frac{f(x_n)}{f'(x_n)}$

Here  $f(x) = xe^x - 2$   
 $f'(x) = xe^x + e^x$

**Step 1:**  $x_1 = x_0 - \frac{f(x_0)}{f'(x_0)}$   
 $x_1 = 1 - \frac{f(1)}{f'(1)}$   
 $x_1 = 1 - \frac{(0.718)}{(5.437)}$   
 $x_1 = \mathbf{0.868}$

**Step 2:**  $x_2 = x_1 - \frac{f(x_1)}{f'(x_1)}$   
 $x_2 = 0.868 - \frac{f(0.868)}{f'(0.868)}$   
 $x_2 = 0.868 - \frac{(0.068)}{(4.450)}$   
 $x_2 = \mathbf{0.853}$

**Step 3:**  $x_3 = x_2 - \frac{f(x_2)}{f'(x_2)}$   
 $x_3 = 0.853 - \frac{f(0.853)}{f'(0.853)}$   
 $x_3 = 0.853 - \frac{(0.002)}{(4.348)}$   
 $x_3 = \mathbf{0.853}$

$\therefore$  The real root is 0.853.

5. Use NR method to find the real root of the equation  $x + \log_{10} x = 2$ .

**Sol:** Given  $f(x) = x + \log_{10} x - 2$

$f(1) = -1 < 0$

$f(2) = 0.3010 > 0$

The root lies between (1,2).

Since  $f(2)$  lies nearer to 0.

Let  $x_0 = 2$

We know that  $x_{n+1} = x_n - \frac{f(x_n)}{f'(x_n)}$

Here  $f(x) = x + \log_{10} x - 2$

$f'(x) = 1 + \frac{1}{x} \log_{10} e - 0$

$f'(x) = 1 + \frac{0.4343}{x}$

**Step 1:**  $x_1 = x_0 - \frac{f(x_0)}{f'(x_0)}$   
 $x_1 = (2) - \frac{f(2)}{f'(2)}$   
 $x_1 = (2) - \frac{(0.3010)}{1.2172}$   
 $x_1 = \mathbf{1.7527}$

**Step 2:**  $x_2 = x_1 - \frac{f(x_1)}{f'(x_1)}$   
 $x_2 = 1.7527 - \frac{f(1.7527)}{f'(1.7527)}$   
 $x_2 = 1.7527 - \frac{(-0.0036)}{(1.2478)}$   
 $x_2 = \mathbf{1.7556}$

$$\begin{aligned} \text{Step 3: } x_3 &= x_2 - \frac{f(x_2)}{f'(x_2)} \\ x_3 &= 1.7556 - \frac{f(1.7556)}{f'(1.7556)} \\ x_3 &= 1.7556 - \frac{(0)}{(1.2474)} \\ \mathbf{x_3} &= \mathbf{1.7556} \end{aligned}$$

∴ The real root of the equation is 1.7556.

6. Find the approximate root of the equation  $e^x \sin x - 1 = 0$  using NR method.

**Sol:** Given  $f(x) = e^x \sin x - 1$

$$f(0) = -1 < 0$$

$$f(1) = 1.2874 > 0$$

The root lies between (0,1).

Since  $f(0)$  lies nearer to 0.

Let  $x_0 = 0$

We know that  $x_{n+1} = x_n - \frac{f(x_n)}{f'(x_n)}$

Here  $f(x) = e^x \sin x - 1$

$$f'(x) = e^x \cos x + \sin x \cdot e^x = e^x (\cos x + \sin x)$$

$$\text{Step 1: } x_1 = x_0 - \frac{f(x_0)}{f'(x_0)}$$

$$x_1 = 0 - \frac{f(0)}{f'(0)}$$

$$x_1 = 0 - \frac{(-1)}{(1)}$$

$$\mathbf{x_1 = 1}$$

$$\text{Step 2: } x_2 = x_1 - \frac{f(x_1)}{f'(x_1)}$$

$$x_2 = 1 - \frac{f(1)}{f'(1)}$$

$$x_2 = 1 - \frac{(1.2874)}{(3.7560)}$$

$$\mathbf{x_2 = 0.6572}$$

$$\text{Step 3: } x_3 = x_2 - \frac{f(x_2)}{f'(x_2)}$$

$$x_3 = 0.6572 - \frac{f(0.6572)}{f'(0.6572)}$$

$$x_3 = 0.6572 - \frac{(0.1787)}{(2.7062)}$$

$$\mathbf{x_3 = 0.5912}$$

$$\text{Step 4: } x_4 = x_3 - \frac{f(x_3)}{f'(x_3)}$$

$$x_4 = 0.5912 - \frac{f(0.5912)}{f'(0.5912)}$$

$$x_4 = 0.5912 - \frac{(0.0067)}{(2.5063)}$$

$$\mathbf{x_4 = 0.5885}$$

$$\text{Step 5: } x_5 = x_4 - \frac{f(x_4)}{f'(x_4)}$$

$$x_5 = 0.5885 - \frac{f(0.5885)}{f'(0.5885)}$$

$$x_5 = 0.5885 - \frac{(-0.0001)}{(2.4982)}$$

$$\mathbf{x_5 = 0.5885}$$

∴ The real root of the equation is 0.5885.

7. Derive an iterative formula to find  $\sqrt{N}$  and hence find  $\sqrt{12}$ .

**Sol:** Let  $x = \sqrt{N}$

Square on both sides

$$x^2 = N$$

$$x^2 - N = 0$$

Here  $f(x) = x^2 - N$

$$f'(x) = 2x$$

We know that  $x_{n+1} = x_n - \frac{f(x_n)}{f'(x_n)}$

$$x_{n+1} = x_n - \frac{(x_n^2 - N)}{(2x_n)}$$

$$x_{n+1} = \frac{(2x_n^2 - x_n^2 + N)}{2x_n}$$

$$x_{n+1} = \frac{x_n^2 + N}{2x_n}$$

$$x_{n+1} = \frac{1}{2} \left[ \frac{x_n^2}{x_n} + \frac{N}{x_n} \right]$$

$$\mathbf{x_{n+1} = \frac{1}{2} \left[ x_n + \frac{N}{x_n} \right]}$$
, is an iterative formula.

**To find  $\sqrt{12}$ :**

Here  $N = 12$

Wkt,  $\sqrt{9} = 3$  ,  $\sqrt{16} = 4$

Let  $x_0 = 3$

**Step-1:**  $x_1 = \frac{1}{2} \left[ x_0 + \frac{N}{x_0} \right]$

$$x_1 = \frac{1}{2} \left[ 3 + \frac{12}{3} \right]$$

$$\mathbf{x_1 = 3.5}$$

**Step-2:**  $x_2 = \frac{1}{2} \left[ x_1 + \frac{N}{x_1} \right]$

$$x_2 = \frac{1}{2} \left[ 3.5 + \frac{12}{3.5} \right]$$

$$\mathbf{x_2 = 3.4643}$$

**Step-3:**  $x_3 = \frac{1}{2} \left[ x_2 + \frac{N}{x_2} \right]$

$$x_3 = \frac{1}{2} \left[ 3.4643 + \frac{12}{3.4643} \right]$$

$$\mathbf{x_3 = 3.4641}$$

**Step-4:**  $x_4 = \frac{1}{2} \left[ x_3 + \frac{N}{x_3} \right]$

$$x_4 = \frac{1}{2} \left[ 3.4641 + \frac{12}{3.4641} \right]$$

$$\mathbf{x_4 = 3.4641}$$

Thus,  $\sqrt{12} = 3.4641$ .

8. Use NR method to derive an iterative formula to find cube root of a positive integer N and hence find cube root of 29.

**Sol:** Let  $x = \sqrt[3]{N}$

Cube on both sides

$$x^3 = N$$

$$x^3 - N = 0$$

$$\text{Here } f(x) = x^3 - N$$

$$f'(x) = 3x^2$$

We know that  $x_{n+1} = x_n - \frac{f(x_n)}{f'(x_n)}$

$$x_{n+1} = x_n - \frac{(x_n^3 - N)}{(3x_n^2)}$$

$$x_{n+1} = \frac{(3x_n^3 - x_n^3 + N)}{3x_n^2}$$

$$x_{n+1} = \frac{2x_n^3 + N}{3x_n^2}$$

$$x_{n+1} = \frac{1}{3} \left[ \frac{2x_n^3}{x_n^2} + \frac{N}{x_n^2} \right]$$

$$x_{n+1} = \frac{1}{3} \left[ 2x_n + \frac{N}{x_n^2} \right], \text{ is an iterative formula.}$$

**To find  $\sqrt[3]{29}$ :**

Here  $N = 29$

$$\text{Wkt, } \sqrt{27} = 3, \sqrt{64} = 4$$

$$\text{Let } x_0 = 3$$

$$\text{Step-1: } x_1 = \frac{1}{3} \left[ 2x_0 + \frac{N}{x_0^2} \right]$$

$$x_1 = \frac{1}{3} \left[ 2(3) + \frac{29}{(3)^2} \right]$$

$$x_1 = 3.0741$$

$$\text{Step-2: } x_2 = \frac{1}{3} \left[ 2x_1 + \frac{N}{x_1^2} \right]$$

$$x_2 = \frac{1}{3} \left[ 2(3.0741) + \frac{29}{(3.0741)^2} \right]$$

$$x_2 = 3.0723$$

$$\text{Step-3: } x_3 = \frac{1}{3} \left[ 2x_2 + \frac{N}{x_2^2} \right]$$

$$x_3 = \frac{1}{3} \left[ 2(3.0723) + \frac{29}{(3.0723)^2} \right]$$

$$x_3 = 3.0723$$

Thus,  $\sqrt[3]{29} = 3.0723$ .

9. Use NR method to find an iterative formula for the reciprocal of the square root of a positive number and hence find  $(17)^{-1/2}$  correct to 4 decimal places.

**Sol:** Let  $x = \frac{1}{\sqrt{N}}$

Square on both sides

$$x^2 = \frac{1}{N}$$

$$x^2 - \frac{1}{N} = 0$$

Here  $f(x) = x^2 - \frac{1}{N}$

$$f'(x) = 2x$$

We know that  $x_{n+1} = x_n - \frac{f(x_n)}{f'(x_n)}$

$$x_{n+1} = x_n - \frac{(x_n^2 - \frac{1}{N})}{(2x_n)}$$

$$x_{n+1} = \frac{(2x_n^2 - x_n^2 + \frac{1}{N})}{2x_n}$$

$$x_{n+1} = \frac{x_n^2 + \frac{1}{N}}{2x_n}$$

$$x_{n+1} = \frac{1}{2} \left[ \frac{x_n^2}{x_n} + \frac{\frac{1}{N}}{x_n} \right]$$

$$x_{n+1} = \frac{1}{2} \left[ x_n + \frac{1}{N x_n} \right], \text{ is an iterative formula.}$$

**To find  $(17)^{-1/2}$ :**

Here  $N = 17$

Wkt,  $\frac{1}{\sqrt{9}} = 0.3333$  ,  $\frac{1}{\sqrt{16}} = 0.25$

Let  $x_0 = 0.25$

**Step-1:**  $x_1 = \frac{1}{2} \left[ x_0 + \frac{1}{N \cdot x_0} \right]$

$$x_1 = \frac{1}{2} \left[ 0.25 + \frac{1}{17(0.25)} \right]$$

$$x_1 = \mathbf{0.2426}$$

**Step-2:**  $x_2 = \frac{1}{2} \left[ x_1 + \frac{1}{N \cdot x_1} \right]$

$$x_2 = \frac{1}{2} \left[ 0.2426 + \frac{1}{17(0.2426)} \right]$$

$$x_2 = \mathbf{0.2425}$$

Thus,  $\frac{1}{\sqrt{17}} = \mathbf{0.2425}$

10. Use NR method to find an iterative formula for the reciprocal of positive number and

hence find  $\frac{1}{31}$ .

**Sol:** Let  $x = \frac{1}{N}$

Take reciprocal on b.s

$$\frac{1}{x} = N$$

$$\frac{1}{x} - N = 0$$

Here  $f(x) = \frac{1}{x} - N$

$$f'(x) = -\frac{1}{x^2}$$

We know that  $x_{n+1} = x_n - \frac{f(x_n)}{f'(x_n)}$

$$x_{n+1} = x_n - \frac{\left( \frac{1}{x_n} - N \right)}{\left( -\frac{1}{x_n^2} \right)}$$

$$x_{n+1} = x_n + \left( \frac{1}{x_n} - N \right) \cdot \frac{x_n^2}{1}$$

$$x_{n+1} = x_n + \left( \frac{x_n^2}{x_n} - Nx_n^2 \right)$$

$$x_{n+1} = x_n + x_n - Nx_n^2$$

$$x_{n+1} = 2x_n - Nx_n^2$$

$x_{n+1} = x_n[2 - Nx_n]$ , is an iterative formula.

**To find  $\frac{1}{31}$ :**

Here  $N = 31$

Let  $x_0 = \frac{1}{25} = 0.04$

**Step-1:**  $x_1 = x_0[2 - Nx_0]$

$$x_1 = (0.04)[2 - 31(0.04)]$$

$$x_1 = \mathbf{0.0304}$$

**Step-2:**  $x_2 = x_1[2 - Nx_1]$

$$x_2 = (0.0304)[2 - 31(0.0304)]$$

$$x_2 = \mathbf{0.0322}$$

**Step-3:**  $x_3 = x_2[2 - Nx_2]$

$$x_3 = (0.0322)[2 - 31(0.0322)]$$

$$x_3 = \mathbf{0.0323}$$

Thus,  $\frac{1}{31} = \mathbf{0.0323}$ .

## FINITE DIFFERENCES

### Newton's Forward interpolation formula (NFIF)

The value of  $y = f(x)$  at  $x = x_0 + rh$  is approximately given by

$$y = y_0 + r\Delta y_0 + \frac{r(r-1)}{2!} \Delta^2 y_0 + \frac{r(r-1)(r-2)}{3!} \Delta^3 y_0 + \dots$$

$$+ \frac{r(r-1)(r-2) \dots [r - (n-1)]}{n!} \Delta^n y_0$$

Where, ' $r$ ' is any real number,  $r = \frac{x-x_0}{h}$ ;  $h$  is step length.

### Newton's Backward interpolation formula (NBIF)

The value of  $y = f(x)$  at  $x = x_n + rh$  is approximately given by

$$y = y_n + r\nabla y_n + \frac{r(r+1)}{2!} \nabla^2 y_n + \frac{r(r+1)(r+2)}{3!} \nabla^3 y_n + \dots$$

$$+ \frac{r(r+1)(r+2) \dots [r + (n-1)]}{n!} \nabla^n y_n$$

Where, ' $r$ ' is any real number,  $r = \frac{x-x_n}{h}$ ;  $h$  is step length.

**Problems**

1. Given  $f(0) = 1, f(1) = 3, f(2) = 7, f(3) = 13$ , find  $f(0.1)$  using Newton's forward interpolation formula.

**Sol:**

$x$	$y$	$I D$	$II D$	$III D$
$x_0 = 0$	$y_0 = 1$			
1	3	$\Delta y_0 = 3 - 1 = 2$	$\Delta^2 y_0 = 4 - 2 = 2$	$\Delta^3 y_0 = 2 - 2 = 0$
2	7	$7 - 3 = 4$	$6 - 4 = 2$	
3	13	$13 - 7 = 6$		

Now  $h = 1, x_0 = 0$       **To find  $f(0.1) \Rightarrow x = 0.1$**

$$r = \frac{x-x_0}{h}$$

$$r = \frac{0.1-0}{1}$$

$$r = 0.1$$

**By NFIF,**

$$y = y_0 + r\Delta y_0 + \frac{r(r-1)}{2!}\Delta^2 y_0 + \frac{r(r-1)(r-2)}{3!}\Delta^3 y_0 + \dots$$

$$y = 1 + (0.1)(2) + \frac{(0.1)(0.1-1)}{2}(2) + \frac{(0.1)(0.1-1)(0.1-2)}{6}(0)$$

$$y = 1.11$$

Thus,  **$f(0.1) = 1.11$**

2. A function  $y = f(x)$  is given by the following table

$x$	1	1.2	1.4	1.6	1.8	2
$y = f(x)$	0	0.128	0.544	1.296	2.432	4

Find an approximate value of  $f(1.1)$ .

**Sol:** Here  $h = 0.2, x_0 = 1$       **To find  $f(1.1) \Rightarrow x = 1.1$**

$$r = \frac{x-x_0}{h}$$

$$r = \frac{1.1-1}{0.2}$$

$$r = \frac{0.1}{0.2}$$

$$r = 0.5$$

$x$	$y$	$I D$	$II D$	$III D$	$IV D$	$V D$
$x_0 = 1$	$y_0 = 0$					
1.2	0.128	$\Delta y_0 = 0.128$				
1.4	0.544	0.416	$\Delta^2 y_0 = 0.288$			
1.6	1.296	0.752	0.336	$\Delta^3 y_0 = 0.048$	$\Delta^4 y_0 = 0$	$\Delta^5 y_0 = 0$
1.8	2.432	1.136	0.384	0.048	0	
2	4	1.568	0.432	0.048		

By NFIF,

$$y = y_0 + r\Delta y_0 + \frac{r(r-1)}{2!}\Delta^2 y_0 + \frac{r(r-1)(r-2)}{3!}\Delta^3 y_0 + \frac{r(r-1)(r-2)(r-3)}{4!}\Delta^4 y_0 + \frac{r(r-1)(r-2)(r-3)(r-4)}{5!}\Delta^5 y_0$$

$$y = 0 + (0.5)(0.128) + \frac{(0.5)(0.5-1)}{2}(0.288) + \frac{(0.5)(0.5-1)(0.5-2)}{6}(0.048) + 0 + 0$$

$$y = 0.0310$$

Thus,  $f(1.1) = 0.0310$ .

3. Find  $u_{0.5}$  from the data  $u_0 = 225, u_1 = 238, u_2 = 320, u_3 = 340$ .

Sol:  $h = 1, x_0 = 0$  To find  $u_{0.5} \Rightarrow x = 0.5$

$$r = \frac{x-x_0}{h}$$

$x$	$y$	$I D$	$II D$	$III D$
$x_0 = 0$	$y_0 = 225$			
1	238	$\Delta y_0 = 13$		
2	320	82	$\Delta^2 y_0 = 69$	
3	340	20	-62	$\Delta^3 y_0 = -131$

$$r = \frac{0.5-0}{1} = 0.5$$

By NFIF,

$$y = y_0 + r\Delta y_0 + \frac{r(r-1)}{2!}\Delta^2 y_0 + \frac{r(r-1)(r-2)}{3!}\Delta^3 y_0 + \dots$$

$$y = 225 + (0.5)(13) + \frac{(0.5)(0.5-1)}{2}(69) + \frac{(0.5)(0.5-1)(0.5-2)}{6}(-131)$$

$$y = 214.6875$$

Thus,  $u_{0.5} = 214.6875$

4. Find the area of a circle corresponding to diameter (D) is given below

D	80	85	90	95	100
A	5026	5674	6362	7088	7854

Find the area corresponding to the diameter 105 using appropriate interpolation formula.

**Sol:** Here  $h = 5$  ,  $x_n = 100$       **To find  $f(105) \Rightarrow x = 10.5$**

$$r = \frac{x-x_n}{h}$$

$$r = \frac{105-100}{5}$$

$$r = 1$$

x	y	I D	II D	III D	IV D
80	5026	648			
85	5674	688	40	-2	
90	6362	726	38	$\nabla^3 y_n = 2$	$\nabla^4 y_n = 4$
95	7088	$\nabla y_n = 766$	$\nabla^2 y_n = 40$		
$x_n = 100$	$y_n = 7854$				

**By NBIF,**

$$y = y_n + r\nabla y_n + \frac{r(r+1)}{2!} \nabla^2 y_n + \frac{r(r+1)(r+2)}{3!} \nabla^3 y_n + \frac{r(r+1)(r+2)(r+3)}{4!} \nabla^4 y_n$$

$$y = 7854 + (1)(766) + \frac{(1)(1+1)}{2} (40) + \frac{(1)(1+1)(1+2)}{6} (2)$$

$$+ \frac{(1)(1+1)(1+2)(1+3)}{24} (4)$$

$$y = 8666$$

Thus,  $f(105) = 8666$ .

The area corresponding to the diameter 105 is 8666.

5. The following table give the values of  $\tan x$  for  $0.1 \leq x \leq 0.3$  , find  $\tan(0.26)$ .

x	0.1	0.15	0.2	0.25	0.3
$\tan x$	0.1003	0.1511	0.2027	0.2553	0.3093

**Sol:**

Here  $h = 0.05$  ,  $x_n = 0.3$

**To find  $\tan(0.26) \Rightarrow x = 0.26$**

$$r = \frac{x-x_n}{h}$$

$$r = \frac{0.26-0.3}{0.05}$$

$$r = -0.08$$

$x$	$y$	$I D$	$II D$	$III D$	$IV D$
0.1	0.1003	0.0508			
0.15	0.1511	0.0516	0.0008	0.0002	
0.2	0.2027	0.0526	0.0010		$\nabla^4 y_n$ $= 0.0002$
0.25	0.2553		$\nabla^2 y_n$ $= 0.0014$	$\nabla^3 y_n$ $= 0.0004$	
$x_n = 0.3$	$y_n = 0.3093$	$\nabla y_n$ $= 0.0540$			

By NBIF,

$$y = y_n + r\nabla y_n + \frac{r(r+1)}{2!} \nabla^2 y_n + \frac{r(r+1)(r+2)}{3!} \nabla^3 y_n + \frac{r(r+1)(r+2)(r+3)}{4!} \nabla^4 y_n$$

$$y = 0.3093 + (-0.8)(0.0540) + \frac{(-0.8)(-0.8+1)}{2} (0.0014)$$

$$+ \frac{(-0.8)(-0.8+1)(-0.8+2)}{6} (0.0004)$$

$$+ \frac{(-0.8)(-0.8+1)(-0.8+2)(-0.8+3)}{24} (0.0002)$$

$$y = 0.2660$$

Thus,  $\tan(0.26) = 0.2660$ .

6. From the following table find the number of students who have obtain

- Less than 45 marks
- Between 40 – 45 marks
- More than 40 but less than 55

Marks	30-40	40-50	50-60	60-70	70-80
No. of students	31	42	51	35	31

Sol:

$x$	$y$	$I D$	$II D$	$III D$	$IV D$
$x_0 = 40$	$y_0 = 31$				
50	73 (31+42)	$\Delta y_0 = 42$	$\Delta^2 y_0 = 9$		
60	124 (73+51)	51	-16	$\Delta^3 y_0$ $= -25$	$\Delta^4 y_0 = 37$
70	159 (124+35)	35	-4		
		31		12	

<b>80</b>	<b>190 (159+31)</b>				
-----------	---------------------	--	--	--	--

a) To find  $f(45) \Rightarrow x = 45$

Here  $h = 10$  ,  $x_0 = 40$

$$r = \frac{x-x_0}{h}$$

$$r = \frac{45-40}{10}$$

$$r = 0.5$$

By NFIF,

$$y = y_0 + r\Delta y_0 + \frac{r(r-1)}{2!} \Delta^2 y_0 + \frac{r(r-1)(r-2)}{3!} \Delta^3 y_0 + \frac{r(r-1)(r-2)(r-3)}{4!} \Delta^4 y_0$$

$$y = 31 + (0.5)(42) + \frac{(0.5)(0.5-1)}{2} (9) + \frac{(0.5)(0.5-1)(0.5-2)}{6} (-25) + \frac{(0.5)(0.5-1)(0.5-2)(0.5-3)}{24} (37)$$

$$y = 47.8672 \cong 48$$

Thus,  $f(45) = 48$ .

No. of students who have obtained less than 45 marks is 48.

$$\begin{aligned} \text{b) The no. of students between 40 to 45 marks} &= f(45) - f(40) \\ &= 48 - 31 \\ &= 17 \end{aligned}$$

c) To find  $f(55) \Rightarrow x = 55$

Here  $h = 10$  ,  $x_0 = 40$

$$r = \frac{x-x_0}{h}$$

$$r = \frac{55-40}{10}$$

$$r = 1.5$$

By NFIF,

$$y = y_0 + r\Delta y_0 + \frac{r(r-1)}{2!} \Delta^2 y_0 + \frac{r(r-1)(r-2)}{3!} \Delta^3 y_0 + \frac{r(r-1)(r-2)(r-3)}{4!} \Delta^4 y_0$$

$$\begin{aligned} y = 31 + (1.5)(42) + \frac{(1.5)(1.5-1)}{2} (9) + \frac{(1.5)(1.5-1)(1.5-2)}{6} (-25) \\ + \frac{(1.5)(1.5-1)(1.5-2)(1.5-3)}{24} (37) \end{aligned}$$

$$y = 99.8047 \cong 100$$

Thus,  $f(55) = 100$ .

$$\begin{aligned} \text{No. of students who have obtained more than 40 but less than 55} &= f(55) - f(40) \\ &= 100 - 31 \\ &= 69 \end{aligned}$$

7. The population of a town is given by the following data

Year	1971	1981	1991	2001	2011
Population (in thousand)	19.96	39.65	58.81	77.18	94.58

Using appropriate interpolation formula calculate the increase in the population from the year 1975 to 2005.

**Sol:**

$x$	$y$	$I D$	$II D$	$III D$	$IV D$
$x_0 = 1971$	$y_0 = 19.96$				
1981	39.65	$\Delta y_0 = 19.69$			
1991	58.81	19.16	$\Delta^2 y_0 = -0.53$		
2001	77.18	18.37	-0.79	$\Delta^3 y_0 = -0.26$	
$x_n = 2011$	$y_n = 94.58$	$\nabla y_n = 17.40$	$\nabla^2 y_n = -0.97$	$\nabla^3 y_n = -0.18$	$\Delta^4 y_0 = 0.08$ $= \nabla^4 y_n$

a) To find  $f(1975) \Rightarrow x = 1975$

Here  $h = 10$ ,  $x_0 = 1971$

$$r = \frac{x - x_0}{h}$$

$$r = \frac{1975 - 1971}{10}$$

$$r = 0.4$$

**By NFIF,**

$$\begin{aligned} y &= y_0 + r\Delta y_0 + \frac{r(r-1)}{2!}\Delta^2 y_0 + \frac{r(r-1)(r-2)}{3!}\Delta^3 y_0 + \frac{r(r-1)(r-2)(r-3)}{4!}\Delta^4 y_0 \\ y &= 19.96 + (0.4)(19.69) + \frac{(0.4)(0.4-1)}{2}(-0.53) + \frac{(0.4)(0.4-1)(0.4-2)}{6}(-0.26) \\ &\quad + \frac{(0.4)(0.4-1)(0.4-2)(0.4-3)}{24}(0.08) \end{aligned}$$

$$y = 27.8797$$

Thus,  $f(1975) = 27.8797$

**To find  $f(2005) \Rightarrow x = 2005$**

Here  $h = 0.05$ ,  $x_n = 2011$

$$r = \frac{x - x_n}{h}$$

$$r = \frac{2005-2011}{10}$$

$$r = -0.6$$

By NBIF,

$$y = y_n + r\nabla y_n + \frac{r(r+1)}{2!} \nabla^2 y_n + \frac{r(r+1)(r+2)}{3!} \nabla^3 y_n + \frac{r(r+1)(r+2)(r+3)}{4!} \nabla^4 y_n$$

$$y = 94.58 + (-0.6)(17.40) + \frac{(-0.6)(-0.6+1)}{2} (-0.97)$$

$$+ \frac{(-0.6)(-0.6+1)(-0.6+2)}{6} (-0.18)$$

$$+ \frac{(-0.6)(-0.6+1)(-0.6+2)(-0.6+3)}{24} (0.08)$$

$$y = 84.2638$$

Thus,  $f(2015) = 84.2638$

The increase in population from the year 1975 to 2005 =  $f(1975) - f(2005)$   
 $= 84.2638 - 27.8797$   
 $= 56.3841$  ( in thousands )

8. Extrapolate for 25.4 given the data

<b>x</b>	<b>19</b>	<b>20</b>	<b>21</b>	<b>22</b>	<b>23</b>
<b>y</b>	91	100.25	110	120.25	131

9. In a table given below the values of y are consecutive terms of a series of which 23.6 is the 6th term , find the 1st and 10th term of series

<b>x</b>	<b>3</b>	<b>4</b>	<b>5</b>	<b>6</b>	<b>7</b>	<b>8</b>	<b>9</b>
<b>y</b>	4.8	8.4	14.5	23.6	36.2	54.8	73.9

10. Given  $\sin(45) = 0.7071$ ,  $\sin(50) = 0.7660$ ,  $\sin(55) = 0.8192$ ,  $\sin(60) = 0.8660$ , find  $\sin(52)$  and  $\sin(57)$  using an appropriate interpolation formula.

### *Interpolation formula for unequal intervals*

#### *Newton's Divided Difference Formula or Newton's general interpolation formula*

If  $f(x_0), f(x_1), f(x_2), \dots, f(x_n)$  be a set of values of an unknown function  $f(x)$  corresponding to the values  $x_0, x_1, x_2, \dots, x_n$  at unequal intervals, then

$$y = f(x_0) + (x - x_0)f(x_0, x_1) + (x - x_0)(x - x_1)f(x_0, x_1, x_2) + \dots$$

$$+ (x - x_0)(x - x_1) \dots (x - x_{n-1})f(x_0, x_1, \dots, x_n)$$

Here  $f(x_0, x_1) = \frac{f(x_1) - f(x_0)}{(x_1 - x_0)}$  ;  $f(x_0, x_1, x_2) = \frac{f(x_1, x_2) - f(x_0, x_1)}{(x_2 - x_0)}$  ;

$$f(x_0, x_1, x_2, x_3) = \frac{f(x_1, x_2, x_3) - f(x_0, x_1, x_2)}{(x_3 - x_0)}$$

**Problems**

1. Use NDDF to find  $f(43)$ , given that

$x$	40	42	44	45
$f(x)$	43833	46568	49431	50912

**Sol:**

$x$	$f(x)$	<i>I DD</i>	<i>II DD</i>	<i>III DD</i>
$x_0$ = 40	$f(x_0)$ = 43833	$f(x_0, x_1)$ $= \frac{46568 - 43833}{42 - 40}$ = 1367.5	$f(x_0, x_1, x_2)$ $= \frac{1431.5 - 1367.5}{44 - 40}$ = 16	$f(x_0, x_1, x_2, x_3)$ $= \frac{16.5 - 16}{45 - 40} = 0.1$
$x_1$ = 42	$f(x_1)$ = 46568	$f(x_1, x_2)$ $= \frac{49431 - 46568}{44 - 42}$ = 1431.5	$f(x_1, x_2, x_3)$ $= \frac{1481 - 1431.5}{45 - 42} = 16.5$	
$x_2$ = 44	$f(x_2)$ = 49431	$f(x_2, x_3)$ $= \frac{50912 - 49431}{45 - 44}$ = 1481		
$x_3$ = 45	$f(x_3)$ = 50912			

By NDDF,

$$y = f(x_0) + (x - x_0)f(x_0, x_1) + (x - x_0)(x - x_1)f(x_0, x_1, x_2) + (x - x_0)(x - x_1)(x - x_2)f(x_0, x_1, x_2, x_3)$$

$$y = 43833 + (43 - 40)(1367.5) + (43 - 40)(43 - 42)(16) + (43 - 40)(43 - 42)(43 - 44)(0.1)$$

$$y = 47983.2$$

**Thus,  $f(43) = 47983.2$**

2. Find  $f(0.05)$  using NDDF given that

$x$	0	2	3	5	6
$f(x)$	0	6	21	105	186

**Sol:**

$x$	$f(x)$	<i>I DD</i>	<i>II DD</i>	<i>III DD</i>	<i>IV DD</i>
$x_0 = 0$	$f(x_0) = 0$				
$x_1 = 2$	$f(x_1) = 6$	$f(x_0, x_1)$ $= 3$	$f(x_0, x_1, x_2)$ $= 4$		
$x_2 = 3$	$f(x_2) = 21$			$f(x_0, x_1, x_2, x_3)$ $= 1$	
$x_3 = 5$	$f(x_3) = 105$	$f(x_1, x_2)$ $= 15$	$f(x_1, x_2, x_3)$ $= 9$		$f(x_0, x_1, x_2, x_3, x_4)$ $= 0$
$x_4 = 6$	$f(x_4) = 186$	$f(x_2, x_3)$ $= 42$	$f(x_2, x_3, x_4)$ $= 13$	$f(x_1, x_2, x_3, x_4)$ $= 1$	
		$f(x_3, x_4)$ $= 81$			

By NDDF,

$$y = f(x_0) + (x - x_0)f(x_0, x_1) + (x - x_0)(x - x_1)f(x_0, x_1, x_2) \\ + (x - x_0)(x - x_1)(x - x_2)f(x_0, x_1, x_2, x_3) \\ + (x - x_0)(x - x_1)(x - x_2)(x - x_3)f(x_0, x_1, x_2, x_3, x_4)$$

$$y = 0 + (0.5 - 0)(3) + (0.5 - 0)(0.5 - 2)(4) + (0.5 - 0)(0.5 - 2)(0.5 - 3)(1) + (0) \\ \mathbf{y = 0.3750}$$

Thus,  $f(0.5) = 0.3750$

3. Fit an interpolating polynomial for the data by NDDF

$x$	<b>0</b>	<b>1</b>	<b>2</b>	<b>5</b>
$f(x)$	2	3	12	147

Sol:

$x$	$f(x)$	$I DD$	$II DD$	$III DD$
$x_0 = 2$	$f(x_0) = 4$			
$x_1 = 4$	$f(x_1) = 56$	$f(x_0, x_1) = 26$	$f(x_0, x_1, x_2) = 15$	
$x_2 = 9$	$f(x_2) = 711$	$f(x_1, x_2) = 131$	$f(x_1, x_2, x_3) = 23$	$f(x_0, x_1, x_2, x_3) = 1$
$x_3 = 10$	$f(x_3) = 980$	$f(x_2, x_3) = 269$		

By NDDF,

$$y = f(x_0) + (x - x_0)f(x_0, x_1) + (x - x_0)(x - x_1)f(x_0, x_1, x_2) + (x - x_0)(x - x_1)(x - x_2)f(x_0, x_1, x_2, x_3)$$

$$y = 4 + (x - 2)(26) + (x - 2)(x - 4)(15) + (x - 2)(x - 4)(x - 9)(1)$$

$$y = 4 + 26x - 52 + 15(x^2 - 2x - 4x + 8) + (x^2 - 2x - 4x + 8)(x - 9)$$

$$y = 4 + 26x - 52 + 15(x^2 - 6x + 8) + (x^2 - 6x + 8)(x - 9)$$

$$y = 4 + 26x - 52 + 15x^2 - 90x + 120 + x^3 - 6x^2 + 8x - 9x^2 + 54x - 72$$

$y = x^3 - 2x$ , is the required polynomial.

$$f(x) = x^3 - 2x$$

When  $x = 3$ ,  $f(3) = 21$

$x = 5$ ,  $f(5) = 115$

$x = 7$ ,  $f(7) = 329$

$x = 11$ ,  $f(11) = 1309$

Consider,

$$f(x) = x^3 - 2x$$

$$f(x) = (x - 1)^3 + 3x^2 - 3x + 1 - 2x$$

$$f(x) = (x - 1)^3 + 3x^2 - 5x + 1$$

$$f(x) = (x - 1)^3 + 3[(x - 1)^2 + 2x - 1] - 5x + 1$$

$$f(x) = (x - 1)^3 + 3(x - 1)^2 + 6x - 3 - 5x + 1$$

$$f(x) = (x - 1)^3 + 3(x - 1)^2 + x - 2$$

$$f(x) = (x - 1)^3 + 3(x - 1)^2 + x - 1 - 1$$

$$f(x) = (x - 1)^3 + 3(x - 1)^2 + (x - 1) - 1$$

When

$x = 1.1$ ,  $f(x) = (1.1 - 1)^3 + 3(1.1 - 1)^2 + (1.1 - 1) - 1 = -0.8690$

$x = 1.5$ ,  $f(x) = (1.5 - 1)^3 + 3(1.5 - 1)^2 + (1.5 - 1) - 1 = 0.375$

5. Determine  $f(x)$  as a polynomial in  $x$  for the following data using NDDF

$x$	-4	-1	0	2	5
$f(x)$	1245	33	5	9	1335

**Sol:**

$x$	$f(x)$	<i>I DD</i>	<i>II DD</i>	<i>III DD</i>	<i>IV DD</i>
$x_0 = -4$	$f(x_0) = 1245$	$f(x_0, x_1) = -404$	$f(x_0, x_1, x_2) = 94$	$f(x_0, x_1, x_2, x_3) = -14$	$f(x_0, x_1, x_2, x_3, x_4) = 3$
$x_1 = -1$	$f(x_1) = 33$				
$x_2 = 0$	$f(x_2) = 5$ $f(x_3) = 9$	$f(x_1, x_2) = -28$	$f(x_1, x_2, x_3) = 10$	$f(x_1, x_2, x_3, x_4) = 13$	
$x_3 = 2$			$f(x_2, x_3, x_4) = 88$		
$x_4 = 5$	$f(x_4) = 1335$	$f(x_2, x_3) = 2$ $f(x_3, x_4) = 442$			

By NDDF,

$$y = f(x_0) + (x - x_0)f(x_0, x_1) + (x - x_0)(x - x_1)f(x_0, x_1, x_2) + (x - x_0)(x - x_1)(x - x_2)f(x_0, x_1, x_2, x_3) + (x - x_0)(x - x_1)(x - x_2)(x - x_3)f(x_0, x_1, x_2, x_3, x_4)$$

$$y = 1245 + (x + 4)(-404) + (x + 4)(x + 1)(94) + (x + 4)(x + 1)(x - 0)(-14) + (x + 4)(x + 1)(x - 0)(x - 2)(3)$$

$$y = 1245 - 404x - 1616 + 94(x^2 + 5x + 4) - 14x(x^2 + 5x + 4) + 3x(x - 2)(x^2 + 5x + 4)$$

$$y = 1245 - 404x - 1616 + 94x^2 + 470x + 376 - 14x^2 - 70x^2 - 56x + (3x^2 - 6x)(x^2 + 5x + 4)$$

$$y = 1245 - 404x - 1616 + 94x^2 + 470x + 376 - 14x^2 - 70x^2 - 56x + 3x^4 + 15x^3 + 12x^2 - 6x^3 - 30x^2 - 24x$$

$y = 3x^4 - 5x^3 + 6x^2 - 14x + 5$ , is the required polynomial.

6. Construct a polynomial for the data given below using NDDF and hence find  $f(8)$  and  $f(15)$ .

$x$	4	5	7	10	11	13
$f(x)$	48	100	294	900	1210	2028

7. Using NDDF find  $u_8$  if

$x$	1	2	4	7	12
$f(x)$	576	168	-30	48	378

**Lagrange's formula for interpolation**

If  $f(x_0), f(x_1), f(x_2), \dots, f(x_n)$  be a set of values of an unknown function  $f(x)$  corresponding to the values  $x_0, x_1, x_2, \dots, x_n$  not necessarily at equal intervals, then

$$y = f(x) = \frac{(x - x_1)(x - x_2) \dots (x - x_n)}{(x_0 - x_1)(x_0 - x_2) \dots (x_0 - x_n)} y_0 + \frac{(x - x_0)(x - x_2) \dots (x - x_n)}{(x_1 - x_0)(x_1 - x_2) \dots (x_1 - x_n)} y_1 + \dots$$

$$+ \frac{(x - x_0)(x - x_1) \dots (x - x_{n-1})}{(x_n - x_0)(x_n - x_1) \dots (x_n - x_{n-1})} y_n$$

**Lagrange's inverse interpolation formula for  $x = f(y)$  is**

$$x = f(y) = \frac{(y - y_1)(y - y_2) \dots (y - y_n)}{(y_0 - y_1)(y_0 - y_2) \dots (y_0 - y_n)} x_0 + \frac{(y - y_0)(y - y_2) \dots (y - y_n)}{(y_1 - y_0)(y_1 - y_2) \dots (y_1 - y_n)} x_1 + \dots$$

$$+ \frac{(y - y_0)(y - y_1) \dots (y - y_{n-1})}{(y_n - y_0)(y_n - y_1) \dots (y_n - y_{n-1})} x_n$$

**Problems**

1. Apply Lagrange's interpolation formula to find  $y(11)$  from the following data

$x$	2	5	8	14
$y$	94.8	87.9	81.3	68.7

**Sol:** Given  $x_0 = 2$        $x_1 = 5$        $x_2 = 8$        $x_3 = 14$   
 $y_0 = 94.8$      $y_1 = 87.9$      $y_2 = 81.3$      $y_3 = 68.7$

**To find  $y(11) \Rightarrow x = 11$**

Wkt

$$y = \frac{(x - x_1)(x - x_2)(x - x_3)}{(x_0 - x_1)(x_0 - x_2)(x_0 - x_3)} y_0 + \frac{(x - x_0)(x - x_2)(x - x_3)}{(x_1 - x_0)(x_1 - x_2)(x_1 - x_3)} y_1$$

$$+ \frac{(x - x_0)(x - x_1)(x - x_3)}{(x_2 - x_0)(x_2 - x_1)(x_2 - x_3)} y_2 + \frac{(x - x_0)(x - x_1)(x - x_2)}{(x_3 - x_0)(x_3 - x_1)(x_3 - x_2)} y_3$$

$$y = \frac{(11 - 5)(11 - 8)(11 - 14)}{(2 - 5)(2 - 8)(2 - 14)} (94.8) + \frac{(11 - 2)(11 - 8)(11 - 14)}{(5 - 2)(5 - 8)(5 - 14)} (87.9)$$

$$+ \frac{(11 - 2)(11 - 5)(11 - 14)}{(8 - 2)(8 - 5)(8 - 14)} (81.3) + \frac{(11 - 2)(11 - 5)(11 - 8)}{(14 - 2)(14 - 5)(14 - 8)} (68.7)$$

$y = 74.925$

**$y(11) = 74.925$**

2. Fit an interpolating polynomial for the following data

$x$	0	1	2	5
$y$	2	3	12	147

**Sol:** Given  $x_0 = 0$        $x_1 = 1$        $x_2 = 2$        $x_3 = 5$   
 $y_0 = 2$        $y_1 = 3$        $y_2 = 12$        $y_3 = 147$

Wkt

$$y = \frac{(x-x_1)(x-x_2)(x-x_3)}{(x_0-x_1)(x_0-x_2)(x_0-x_3)}y_0 + \frac{(x-x_0)(x-x_2)(x-x_3)}{(x_1-x_0)(x_1-x_2)(x_1-x_3)}y_1$$

$$+ \frac{(x-x_0)(x-x_1)(x-x_3)}{(x_2-x_0)(x_2-x_1)(x_2-x_3)}y_2 + \frac{(x-x_0)(x-x_1)(x-x_2)}{(x_3-x_0)(x_3-x_1)(x_3-x_2)}y_3$$

$$y = \frac{(x-1)(x-2)(x-5)}{(0-1)(0-2)(0-5)}(2) + \frac{(x-0)(x-2)(x-5)}{(1-0)(1-2)(1-5)}(3) + \frac{(x-0)(x-1)(x-5)}{(2-0)(2-1)(2-5)}(12) + \frac{(x-0)(x-1)(x-2)}{(5-0)(5-1)(5-2)}(147)$$

Wkt  $(x-a)(x-b)(x-c) = x^3 - (a+b+c)x^2 + (ab+bc+ca)x - abc$

$$y = \frac{(x^3 - 8x^2 + 17x - 10)}{(-10)}(2) + \frac{(x^3 - 7x^2 + 10x)}{(4)}(3) + \frac{(x^3 - 6x^2 + 5x)}{(-6)}(12)$$

$$+ \frac{(x^3 - 3x^2 + 2x)}{(60)}(147)$$

$$y = \frac{-(x^3 - 8x^2 + 17x - 10)}{5} + \frac{(3x^3 - 21x^2 + 30x)}{4} - \frac{(2x^3 - 12x^2 + 10x)}{1}$$

$$+ \frac{(147x^3 - 441x^2 + 294x)}{60}$$

$$y = \frac{-12(x^3 - 8x^2 + 17x - 10) + 15(3x^3 - 21x^2 + 30x) - 60(2x^3 - 12x^2 + 10x) + (147x^3 - 441x^2 + 294x)}{60}$$

$$y = \frac{-12x^3 + 96x^2 - 204x + 120 + 45x^3 - 315x^2 + 450x - 120x^3 + 720x^2 - 600x + 147x^3 - 441x^2 + 294x}{60}$$

$$y = \frac{60x^3 + 60x^2 - 60x + 120}{60}$$

$y = x^3 + x^2 - x + 2$ , is the required polynomial.

3. Use Lagrange's interpolation formula to fit a polynomial for the data and hence find  $y$  at  $x = 2$ .

$x$	0	1	3	4
$y$	-12	0	6	12

**Sol:** Given  $x_0 = 0$        $x_1 = 1$        $x_2 = 3$        $x_3 = 4$   
 $y_0 = -12$        $y_1 = 0$        $y_2 = 6$        $y_3 = 12$

Wkt

$$y = \frac{(x-x_1)(x-x_2)(x-x_3)}{(x_0-x_1)(x_0-x_2)(x_0-x_3)}y_0 + \frac{(x-x_0)(x-x_2)(x-x_3)}{(x_1-x_0)(x_1-x_2)(x_1-x_3)}y_1$$

$$+ \frac{(x-x_0)(x-x_1)(x-x_3)}{(x_2-x_0)(x_2-x_1)(x_2-x_3)}y_2 + \frac{(x-x_0)(x-x_1)(x-x_2)}{(x_3-x_0)(x_3-x_1)(x_3-x_2)}y_3$$

$$y = \frac{(x-1)(x-3)(x-4)}{(0-1)(0-3)(0-4)}(-12) + \frac{(x-0)(x-3)(x-4)}{(1-0)(1-3)(1-4)}(0)$$

$$+ \frac{(x-0)(x-1)(x-4)}{(3-0)(3-1)(3-4)}(6)$$

$$+ \frac{(x-0)(x-1)(x-3)}{(4-0)(4-1)(4-3)}(12)$$

$$y = \frac{(x^3-8x^2+19x-12)}{(-12)}(-12) + \frac{(x^3-5x^2+4x)}{(-6)}(6) + \frac{(x^3-4x^2+3x)}{(12)}(12)$$

$$y = x^3 - 8x^2 + 19x - 12 - x^3 + 5x^2 - 4x + x^3 - 4x^2 + 3x$$

$y = x^3 - 7x^2 + 18x - 12$ , is the required polynomial.

Put  $x = 2$

$$y = 2^3 - 7(2)^2 + 18(2) - 12$$

$$y = 4$$

4. Use Lagrange's interpolation formula to fit a polynomial for the data  $y(1) = 3$ ,

$$y(3) = 9, y(4) = 30, y(6) = 132.$$

**Sol:** Given  $x_0 = 1$        $x_1 = 3$        $x_2 = 4$        $x_3 = 6$   
 $y_0 = 3$        $y_1 = 9$        $y_2 = 30$        $y_3 = 132$

Wkt

$$y = \frac{(x-x_1)(x-x_2)(x-x_3)}{(x_0-x_1)(x_0-x_2)(x_0-x_3)}y_0 + \frac{(x-x_0)(x-x_2)(x-x_3)}{(x_1-x_0)(x_1-x_2)(x_1-x_3)}y_1$$

$$+ \frac{(x-x_0)(x-x_1)(x-x_3)}{(x_2-x_0)(x_2-x_1)(x_2-x_3)}y_2 + \frac{(x-x_0)(x-x_1)(x-x_2)}{(x_3-x_0)(x_3-x_1)(x_3-x_2)}y_3$$

$$y = \frac{(x-3)(x-4)(x-6)}{(1-3)(1-4)(1-6)}(3) + \frac{(x-1)(x-4)(x-6)}{(3-1)(3-4)(3-6)}(9) \\ + \frac{(x-1)(x-3)(x-6)}{(4-1)(4-3)(4-6)}(30) \\ + \frac{(x-1)(x-3)(x-4)}{(6-1)(6-3)(6-4)}(132)$$

$$y = \frac{(x-3)(x-4)(x-6)}{(-10)} + \frac{3(x-1)(x-4)(x-6)}{(2)} + \frac{5(x-1)(x-3)(x-6)}{(-1)} \\ + \frac{22(x-1)(x-3)(x-4)}{(5)}$$

$$y = \frac{-(x^3 - 13x^2 + 54x - 72) + 15(x^3 - 11x^2 + 34x - 24) - 50(x^3 - 10x^2 + 27x - 18) + 44(x^3 - 8x^2 + 19x - 12)}{10}$$

$$y = \frac{-x^3 + 13x^2 - 54x + 72 + 15x^3 - 165x^2 + 510x - 360 - 50x^3 + 500x^2 - 1350x + 900 + 44x^3 - 352x^2 + 836x - 528}{10}$$

$$y = \frac{8x^3 - 4x^2 - 58x + 84}{10}$$

$$y = \frac{2(4x^3 - 2x^2 - 29x + 42)}{10}$$

$$y = \frac{(4x^3 - 2x^2 - 29x + 42)}{5}, \text{ is the required polynomial.}$$

5. Use Lagrange's interpolation formula to find  $y$  at  $x = 5$  for the data  $y(1) = 3$ ,  $y(3) = 18$ ,  $y(4) = 30$ ,  $y(6) = 132$ .

### **Numerical Integration**

The process of obtaining approximate value of the definite integration  $I = \int_a^b y \, dx$  without actually integrating function but only using the value of ' $y$ ' at some point of  $x$  is equally placed over  $[a, b]$ .

#### **Simpson's $\frac{1}{3}$ rule**

**Formula:**

$$\int_a^b y \, dx = \frac{h}{3} [(y_0 + y_n) + 4(y_1 + y_3 + y_5 + \dots + y_{n-1}) + 2(y_2 + y_4 + y_6 + \dots + y_{n-2})]$$

Where,  $h = \frac{b-a}{n}$

**Note:** To apply  $\frac{1}{3}$  rule  $n$  must be multiple of 2.

### Problems

1. Evaluate  $\int_0^6 3x^2 dx$  dividing the interval  $[0,6]$  in 6 equal parts (7 ordinate) by applying

Simpson's  $\frac{1}{3}$  rule.

**Sol:** Given  $a = 0, b = 6, y = 3x^2$

Now,  $h = \frac{b-a}{n}$

$$h = \frac{6-0}{6}$$

$$h = 1, n = 6$$

$x$	0	1	2	3	4	5	6
$y = 3x^2$	0	3	12	27	48	75	108

Wkt,

$$\int_a^b y dx = \frac{h}{3} [(y_0 + y_6) + 4(y_1 + y_3 + y_5) + 2(y_2 + y_4)]$$

$$\int_0^6 3x^2 dx = \frac{1}{3} [(0 + 108) + 4(3 + 27 + 75) + 2(12 + 48)]$$

$$\int_0^6 3x^2 dx = 216.$$

2. Evaluate  $\int_0^1 \frac{dx}{1+x^2}$  using Simpson's  $\frac{1}{3}$  rule by taking 5 ordinates (4 equal parts) and hence deduce an approximate value of  $\pi$ .

**Sol:** Given  $a = 0, b = 1, y = \frac{1}{1+x^2}$

Now,  $h = \frac{b-a}{n}$

$$h = \frac{1-0}{4}$$

$$h = \frac{1}{4}, n = 4$$

$x$	0	$\frac{1}{4}$	$\frac{2}{4}$	$\frac{3}{4}$	1
$y = \frac{1}{1+x^2}$	1	0.9412	0.8	0.64	0.5

Wkt,

$$\int_a^b y dx = \frac{h}{3} [(y_0 + y_4) + 4(y_1 + y_3) + 2(y_2)]$$

$$\int_0^1 \frac{1}{1+x^2} dx = \frac{1}{3} [(1 + 0.5) + 4(0.9412 + 0.64) + 2(0.8)]$$

$$\int_0^1 \frac{1}{1+x^2} dx = 0.7854$$

**By integration,**

$$\begin{aligned} \int_0^1 \frac{1}{1+x^2} dx &= [\tan^{-1}x]_0^1 \\ 0.7854 &= \tan^{-1}1 - \tan^{-1}0 \\ 0.7854 &= \frac{\pi}{4} \\ \pi &= \mathbf{3.1416} \end{aligned}$$

3. Find the approximate value of  $\int_0^{\pi/2} \sqrt{\cos\theta} d\theta$  by Simpson's  $\frac{1^{rd}}{3}$  rule by dividing  $\left[0, \frac{\pi}{2}\right]$  into 6 equal parts.

**Sol:** Given  $a = 0$ ,  $b = \frac{\pi}{2}$ ,  $y = \sqrt{\cos\theta}$

$$\begin{aligned} \text{Now, } h &= \frac{b-a}{n} \\ h &= \frac{\frac{\pi}{2}-0}{6} ; \\ h &= \frac{\pi}{12} = 15^\circ , \\ n &= 6 \end{aligned}$$

$\theta$	$0^\circ$	$15^\circ$	$30^\circ$	$45^\circ$	$60^\circ$	$75^\circ$	$90^\circ$
$y = \sqrt{\cos\theta}$	1	0.9828	0.9306	0.8409	0.7071	0.5087	0

Wkt,

$$\int_a^b y dx = \frac{h}{3} [(y_0 + y_6) + 4(y_1 + y_3 + y_5) + 2(y_2 + y_4)]$$

$$\int_0^{\frac{\pi}{2}} \sqrt{\cos\theta} d\theta = \frac{\frac{\pi}{2}}{3} [(1 + 0) + 4(0.9828 + 0.8409 + 0.5087) + 2(0.9306 + 0.7071)]$$

$$\int_0^{\frac{\pi}{2}} \sqrt{\cos\theta} d\theta = \mathbf{1.1873}$$

4. Evaluate  $\int_0^{0.6} e^{-x^2} dx$  using Simpson's  $\frac{1^{rd}}{3}$  rule by dividing  $[0,0.6]$  in 6 subintervals.

**Sol:** Given  $a = 0$ ,  $b = 0.6$ ,  $y = e^{-x^2}$

$$\begin{aligned} \text{Now, } h &= \frac{b-a}{n} \\ h &= \frac{0.6-0}{6} \\ h &= \mathbf{0.1}, n = 6 \end{aligned}$$

$x$	0	0.1	0.2	0.3	0.4	0.5	0.6
$y = e^{-x^2}$	1	0.99	0.9608	0.9139	0.8521	0.7788	0.6977

Wkt,

$$\int_a^b y \, dx = \frac{h}{3} [(y_0 + y_6) + 4(y_1 + y_3 + y_5) + 2(y_2 + y_4)]$$

$$\int_0^{0.6} e^{-x^2} \, dx = \frac{0.1}{3} [(1 + 0.6977) + 4(0.99 + 0.9139 + 0.7788) + 2(0.9608 + 0.8521)]$$

$$\int_0^{0.6} e^{-x^2} \, dx = \mathbf{0.5351}$$

5. Evaluate  $\int_0^1 \frac{dx}{(1+x)^2}$  using Simpson's  $\frac{1^{rd}}{3}$  rule by taking 7 ordinates.

**Sol:** Given  $a = 0$ ,  $b = 1$ ,  $y = \frac{1}{(1+x)^2}$

Now,  $h = \frac{b-a}{n}$   
 $h = \frac{1-0}{6}$   
 $h = \frac{1}{6}$ ,  $n = 6$

$x$	0	$\frac{1}{6}$	$\frac{2}{6}$	$\frac{3}{6}$	$\frac{4}{6}$	$\frac{5}{6}$	1
$y = \frac{1}{(1+x)^2}$	1	0.7347	0.5625	0.4444	0.3600	0.2975	0.2500

Wkt,

$$\int_a^b y \, dx = \frac{h}{3} [(y_0 + y_6) + 4(y_1 + y_3 + y_5) + 2(y_2 + y_4)]$$

$$\int_0^1 \frac{1}{(1+x)^2} \, dx = \frac{\frac{1}{6}}{3} [(1 + 0.25) + 4(0.7347 + 0.4444 + 0.2975) + 2(0.5625 + 0.36)]$$

$$\int_0^1 \frac{1}{(1+x)^2} \, dx = \mathbf{0.5001}$$

6. Evaluate  $\int_0^1 \frac{x}{1+x^2} \, dx$  using Simpson's  $\frac{1^{rd}}{3}$  rule by taking 6 equal parts and hence find  $\log 2$ .

**Sol:** Given  $a = 0$ ,  $b = 1$ ,  $y = \frac{x}{1+x^2}$

Now,  $h = \frac{b-a}{n}$   
 $h = \frac{1-0}{6}$   
 $h = \frac{1}{6}$ ,  $n = 6$

$x$	0	$\frac{1}{6}$	$\frac{2}{6}$	$\frac{3}{6}$	$\frac{4}{6}$	$\frac{5}{6}$	1
$y = \frac{x}{1+x^2}$	0	0.1622	0.3000	0.4000	0.4615	0.4918	0.5000

Wkt,

$$\int_a^b y \, dx = \frac{h}{3} [(y_0 + y_6) + 4(y_1 + y_3 + y_5) + 2(y_2 + y_4)]$$

$$\int_0^1 \frac{x}{1+x^2} \, dx = \frac{\frac{1}{6}}{3} [(0 + 0.5) + 4(0.1622 + 0.4 + 0.4918) + 2(0.3 + 0.4615)]$$

$$\int_0^1 \frac{x}{1+x^2} \, dx = \mathbf{0.3466}$$

**By integration,**

$$\int_0^1 \frac{x}{1+x^2} \, dx = \frac{1}{2} \int_0^1 \frac{2x}{1+x^2} \, dx$$

$$0.3466 = \frac{1}{2} [\log(1+x^2)]_0^1$$

$$0.3466 = \frac{1}{2} [\log 2 - \log 1]$$

$$\log 2 = 2 * 0.3466$$

$$\log 2 = \mathbf{0.6932}$$

7. Evaluate  $\int_0^\pi \frac{dx}{2+\cos x}$  by taking 6 sub intervals.

**Sol:** Given  $a = 0$ ,  $b = \pi$ ,  $y = \frac{1}{2+\cos x}$

$$\text{Now, } h = \frac{b-a}{n}$$

$$h = \frac{\pi-0}{6}$$

$$h = \frac{\pi}{6} = \mathbf{30^\circ}, n = 6$$

$x$	$0^\circ$	$30^\circ$	$60^\circ$	$90^\circ$	$120^\circ$	$150^\circ$	$180^\circ$
$\frac{1}{2+\cos x}$	0.3333	0.3489	0.4000	0.5000	0.6667	0.8819	1

Wkt,

$$\int_a^b y \, dx = \frac{h}{3} [(y_0 + y_6) + 4(y_1 + y_3 + y_5) + 2(y_2 + y_4)]$$

$$\int_0^\pi \frac{1}{2+\cos x} \, dx = \frac{\frac{\pi}{6}}{3} [(0.3333 + 1) + 4(0.3489 + 0.5 + 0.8819) + 2(0.4 + 0.6667)]$$

$$\int_0^{\pi} \frac{1}{2+\cos x} dx = 1.8134$$

8. Evaluate  $\int_2^8 \frac{1}{\log_{10} x} dx$  by taking 6 sub intervals.

**Sol:** Given  $a = 2$ ,  $b = 8$ ,  $y = \frac{1}{\log_{10} x}$

Now,  $h = \frac{b-a}{n}$

$$h = \frac{8-2}{6}$$

$$h = 1, n = 6$$

$x$	2	3	4	5	6	7	8
$y = \frac{1}{\log_{10} x}$	3.3219	2.0959	1.6610	1.4307	1.2851	1.1833	1.1073

Wkt,

$$\int_a^b y dx = \frac{h}{3} [(y_0 + y_6) + 4(y_1 + y_3 + y_5) + 2(y_2 + y_4)]$$

$$\int_2^8 \frac{1}{\log_{10} x} dx = \frac{1}{3} [(3.3219 + 1.1073) + 4(2.0959 + 1.4307 + 1.1833) + 2(1.661 + 1.2851)]$$

$$\int_2^8 \frac{1}{\log_{10} x} dx = 9.7203$$

**Simpson's  $\frac{3^{th}}{8}$  rule**

**Formula:**

$$\int_a^b y dx = \frac{3h}{8} [(y_0 + y_n) + 3(y_1 + y_2 + y_4 + \dots + y_{n-1}) + 2(y_3 + y_6 + y_9 + \dots + y_{n-3})]$$

Where,  $h = \frac{b-a}{n}$

**Note:** To apply  $\frac{3^{th}}{8}$  rule  $n$  must be multiple of 3.

**Problems**

1. Evaluate  $\int_0^1 \frac{1}{(1+x)} dx$  by taking 7 ordinate using Simpson's  $\frac{3^{th}}{8}$  rule. Hence deduce the value of  $\log 2$ .

**Sol:** Given  $a = 0$ ,  $b = 1$ ,  $y = \frac{1}{(1+x)}$

Now,  $h = \frac{b-a}{n}$ ,  $n = 6$

$$h = \frac{1-0}{6}$$

$$h = \frac{1}{6}$$

$x$	0	$\frac{1}{6}$	$\frac{2}{6}$	$\frac{3}{6}$	$\frac{4}{6}$	$\frac{5}{6}$	1
$y = \frac{1}{(1+x)}$	1	0.8571	0.75	0.6667	0.6	0.5455	0.5

Wkt,

$$\int_a^b y \, dx = \frac{3h}{8} [(y_0 + y_6) + 3(y_1 + y_2 + y_4 + y_5) + 2(y_3)]$$

$$\int_0^1 \frac{1}{(1+x)} \, dx = \frac{3 \cdot \frac{1}{6}}{8} [(1 + 0.5) + 3(0.8571 + 0.75 + 0.6 + 0.5455) + 2(0.6667)]$$

$$\int_0^1 \frac{1}{(1+x)} \, dx = \mathbf{0.6932}$$

**By integration,**

$$\int_0^1 \frac{1}{1+x} \, dx = [\log(1+x)]_0^1$$

$$0.6932 = [\log 2 - \log 1]$$

$$\log 2 = \mathbf{0.6932}$$

2. Use Simpson's  $\frac{3^{th}}{8}$  rule to evaluate  $\int_1^4 e^{1/x} \, dx$  by taking 3 equal parts.

**Sol:** Given  $a = 1$ ,  $b = 4$ ,  $y = e^{1/x}$

Now,  $h = \frac{b-a}{n}$ ,  $n = 3$

$$h = \frac{4-1}{3}$$

$$\mathbf{h = 1}$$

$x$	1	2	3	4
$y = e^{1/x}$	2.7183	1.6487	1.3956	1.2840

Wkt,

$$\int_a^b y \, dx = \frac{3h}{8} [(y_0 + y_3) + 3(y_1 + y_2)]$$

$$\int_1^4 e^{1/x} \, dx = \frac{3 \cdot 1}{8} [(2.7183 + 1.2840) + 3(1.6487 + 1.3956)]$$

$$\int_1^4 e^{1/x} \, dx = \mathbf{4.9257}$$

3. Evaluate  $\int_4^{5.2} \log_e x \, dx$  using Simpson's  $\frac{3^{th}}{8}$  rule by taking 6 equal parts.

**Sol:** Given  $a = 4$ ,  $b = 5.2$ ,  $y = \log_e x$

Now,  $h = \frac{b-a}{n}$ ,  $n = 6$

$$h = \frac{5.2-4}{6}$$

$$h = 0.2$$

$x$	4	4.2	4.4	4.6	4.8	5.0	5.2
$y = \log_e x$	1.3863	1.4351	1.4816	1.5261	1.5686	1.6094	1.6487

Wkt,

$$\int_a^b y dx = \frac{3h}{8} [(y_0 + y_6) + 3(y_1 + y_2 + y_4 + y_5) + 2(y_3)]$$

$$\int_4^{5.2} \log_e x dx = \frac{3 \cdot (0.2)}{8} [(1.3863 + 1.6487) + 3(1.4351 + 1.4816 + 1.5686 + 1.6094) + 2(1.5261)]$$

$$\int_4^{5.2} \log_e x dx = 1.8278$$

4. Evaluate  $\int_0^{0.3} (1 - 8x^2)^{3/2} dx$  using Simpson's  $\frac{3^{th}}{8}$  rule by taking 7 ordinates.

**Sol:** Given  $a = 0$ ,  $b = 0.3$ ,  $y = (1 - 8x^2)^{3/2}$

Now,  $h = \frac{b-a}{n}$ ,  $n = 6$

$$h = \frac{0.3-0}{6}$$

$$h = 0.05$$

$x$	0	0.05	0.1	0.15	0.2	0.25	0.3
$y = (1 - 8x^2)^{3/2}$	1	0.9702	0.8824	0.7425	0.5607	0.3536	0.1482

Wkt,

$$\int_a^b y dx = \frac{3h}{8} [(y_0 + y_6) + 3(y_1 + y_2 + y_4 + y_5) + 2(y_3)]$$

$$\int_0^{0.3} (1 - 8x^2)^{3/2} dx = \frac{3 \cdot (0.05)}{8} [(1 + 0.1482) + 3(0.9702 + 0.8824 + 0.5607 + 0.3536) + 2(0.7425)]$$

$$\int_0^{0.3} (1 - 8x^2)^{3/2} dx = 0.2050$$

5. Evaluate  $\int_0^1 \frac{x^2}{1+x^3} dx$  using Simpson's  $\frac{3^{th}}{8}$  rule by taking 7 ordinates and hence find  $\log 2$ .

**Sol:** Given  $a = 0$ ,  $b = 1$ ,  $y = \frac{x^2}{1+x^3}$

Now,  $h = \frac{b-a}{n}$ ,  $n = 6$   
 $h = \frac{1-0}{6}$   
 $h = \frac{1}{6}$

$x$	0	$\frac{1}{6}$	$\frac{2}{6}$	$\frac{3}{6}$	$\frac{4}{6}$	$\frac{5}{6}$	1
$y = \frac{x^2}{1+x^3}$	0	0.0276	0.1071	0.2222	0.3429	0.4399	0.5

Wkt,

$$\int_a^b y \, dx = \frac{3h}{8} [(y_0 + y_6) + 3(y_1 + y_2 + y_4 + y_5) + 2(y_3)]$$

$$\int_0^1 \frac{x^2}{1+x^3} \, dx = \frac{3 * \frac{1}{6}}{8} [(0 + 0.5) + 3(0.0267 + 0.1071 + 0.3429 + 0.4399) + 2(0.2222)]$$

$$\int_0^1 \frac{x^2}{1+x^3} \, dx = \mathbf{0.2311}$$

**By integration,**

$$\int_0^1 \frac{x^2}{1+x^3} \, dx = \frac{1}{3} \int_0^1 \frac{3x^2}{1+x^3} \, dx$$

$$0.2311 = \frac{1}{3} [\log(1+x^3)]_0^1$$

$$0.2311 = \frac{1}{3} [\log 2 - \log 1]$$

$$\log 2 = 3 * 0.2311$$

$$\Rightarrow \mathbf{\log 2 = 0.6933}$$

6. Evaluate  $\int_0^6 \frac{dx}{1+x^2}$  using Simpson's  $\frac{3^{th}}{8}$  rule by taking 7 ordinates.

**Sol:** Given  $a = 0$ ,  $b = 6$ ,  $y = \frac{1}{1+x^2}$

Now,  $h = \frac{b-a}{n}$ ,  $n = 6$   
 $h = \frac{6-0}{6}$   
 $h = \mathbf{1}$

$x$	0	1	2	3	4	5	6
$y = \frac{1}{1+x^2}$	1	0.5	0.2	0.1	0.0588	0.0385	0.0270

Wkt,

$$\int_a^b y \, dx = \frac{3h}{8} [(y_0 + y_6) + 3(y_1 + y_2 + y_4 + y_5) + 2(y_3)]$$

$$\int_0^6 \frac{1}{1+x^2} \, dx = \frac{3 \cdot 1}{8} [(1 + 0.5) + 3(0.5 + 0.2 + 0.0588 + 0.0385) + 2(0.1)]$$

$$\int_0^6 \frac{1}{1+x^2} \, dx = \mathbf{1.3571}$$

7. Evaluate  $\int_0^1 \frac{x}{1+x^2} \, dx$  using Simpson's  $\frac{3^{th}}{8}$  rule by taking 3 equal parts and hence find  $\log\sqrt{2}$ .

**Sol:** Given  $a = 0$ ,  $b = 1$ ,  $y = \frac{x}{1+x^2}$

Now,  $h = \frac{b-a}{n}$ ,  $n = 3$

$$h = \frac{1-0}{3}$$

$$\mathbf{h = \frac{1}{3}}$$

$x$	<b>0</b>	$\frac{1}{3}$	$\frac{2}{3}$	<b>1</b>
$y = \frac{x}{1+x^2}$	0	0.3	0.4615	0.5

Wkt,

$$\int_a^b y \, dx = \frac{3h}{8} [(y_0 + y_3) + 3(y_1 + y_2)]$$

$$\int_0^1 \frac{x}{1+x^2} \, dx = \frac{3 \cdot \frac{1}{3}}{8} [(0 + 0.5) + 3(0.3 + 0.4615)]$$

$$\int_0^1 \frac{x}{1+x^2} \, dx = \mathbf{0.3481}$$

**By integration,**

$$\int_0^1 \frac{x}{1+x^2} \, dx = \frac{1}{2} \int_0^1 \frac{2x}{1+x^2} \, dx$$

$$0.3481 = \frac{1}{2} [\log(1+x^2)]_0^1$$

$$0.3481 = \frac{1}{2} [\log 2 - \log 1]$$

$$\frac{1}{2} \log 2 = 0.3481$$

$$\log\sqrt{2} = 0.3481$$

8. Evaluate  $\int_0^{\frac{\pi}{2}} e^{\sin x} dx$  using Simpson's  $\frac{3}{8}$  rule by taking 3 equal parts.

**Sol:** Given  $a = 0$ ,  $b = \frac{\pi}{2}$ ,  $y = e^{\sin x}$

Now,  $h = \frac{b-a}{n}$ ,  $n = 3$

$$h = \frac{\frac{\pi}{2} - 0}{3}$$

$$h = \frac{\pi}{6} = 30^\circ$$

$x$	$0^\circ$	$30^\circ$	$60^\circ$	$90^\circ$
$y = e^{\sin x}$	1	1.6487	2.3774	2.7183

Wkt,

$$\int_a^b y dx = \frac{3h}{8} [(y_0 + y_3) + 3(y_1 + y_2)]$$

$$\int_0^{\frac{\pi}{2}} e^{\sin x} dx = \frac{3 \cdot \frac{\pi}{6}}{8} [(1 + 2.7183) + 3(1.6487 + 2.3774)]$$

$$\int_0^{\frac{\pi}{2}} e^{\sin x} dx = 3.1001$$

## MODULE-5

### NUMERICAL METHODS-2

#### Introduction

A *numerical method* can be used to get an accurate approximate solution to a differential equation. There are many programs and packages available for solving these differential equations. With today's computer, an accurate solution can be obtained rapidly. In this chapter we focus on basic numerical methods for solving initial value problems.

Analytical methods, when available, generally enable to find the value of  $y$  for all values of  $x$ . Numerical methods, on the other hand, lead to the values of  $y$  corresponding only to some finite set of values of  $x$ . That is the solution is obtained as a table of values, rather than as continuous function. Moreover, analytical solution, if it can be found, is exact, whereas a numerical solution inevitably involves an error which should be small but may, if it is not controlled, swamp the true solution. Therefore we must be concerned with two aspects of numerical solutions of ODEs: both the method itself and its accuracy.

The most general form of an ODE of first order and first degree is given by

$$\frac{dy}{dx} = f(x, y) \text{ where } y(x_0) = y_0$$

Let  $x$  be an independent variable and  $y$  be dependent variable.

Let us consider the differential equation  $\frac{dy}{dx} = f(x, y) \text{ where } y(x_0) = y_0$  ----(1)

If particular values are given to the constants, then the resulting solution is called a particular solution.

To obtain a particular solution from the general solution (1), we must be given initial conditions so that the constants can be determined. If all the initial conditions are specified at the same value of  $x$  then the problem is termed as initial value problem. If the conditions are specified at more than one value of  $x$ , then the problem is termed as boundary value problem.

Though there are many analytical methods for finding the solution of the equation of the form (1), there exist large number of ODE's whose solution cannot be obtained by the known analytical methods. In such cases, we use numerical methods to get an approximate solution of a given differential equation under the prescribed conditions

Consider the first order differential equation  $\frac{dy}{dx} = f(x, y)$

Let  $y(x_0), y(x_1), y(x_2), y(x_3) \dots y(x_m)$  be the solution values at the points  $x_0, x_1, x_2, x_3, \dots x_m$

We wish to find the approximate values  $y_0, y_1, \dots, y_m$  to these solution values.

Let the initial condition be  $y(x_0) = y_0$ . Let the exact solution  $y(x)$  of the given differential equation be represented by a continuous curve. Divide the interval  $(x_0, x_m)$  on which the solution is derived into a finite number of equispaced subintervals.

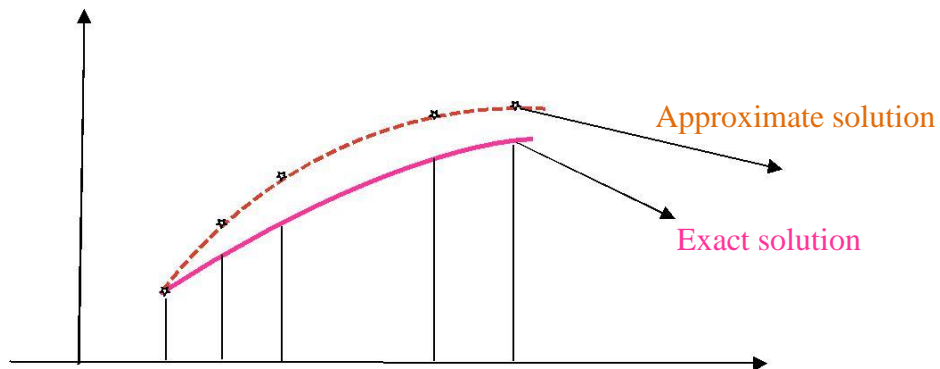

For each  $x_i$ , the approximate values of the dependent variable  $y(x)$  are calculated using a suitable recursive formula. These values are  $y_0, y_1, \dots, y_m$  and these are shown by points. Computation of these approximate values is known as Numerical solution of the Differential equation.

The following methods are used to solve the IVP (1).

1. Taylor's Series Method
2. Modified Euler's Method
3. Runge - Kutta Method
4. Milne's Method

### 1. Taylor's Series Method

Let  $y=f(x)$  be a solution of the equation

Expanding it by Taylor's series about  $x - x_0$  we get

$$f(x) = y_0 + \frac{(x - x_0)}{1!} y'(x_0) + \frac{(x - x_0)^2}{2!} y''(x_0) + \frac{(x - x_0)^3}{3!} y'''(x_0) + \dots$$

1. Compute  $y$  at  $x=1.1$  and  $1.2$  using Taylor's series method to correct to 4 decimal places for

$$\frac{dy}{dx} = x + y, y(0) = 0$$

Solution:

$$y_1 = x + y \quad y_1(0) = 1$$

Differentiate with respect to  $x$  we get

$$y_2 = 1 + y_1 \quad y_2(0) = 2$$

$$y_3 = y_2 \quad y_3(0) = 2$$

$$f(x) = y_0 + \frac{(x - x_0)}{1!} y_1(0) + \frac{(x - x_0)^2}{2!} y_2(0) + \frac{(x - x_0)^3}{3!} y_3(0) + \dots$$

$$y = f(x_1) = y_0 + \frac{h}{1!} y_0^1 + \frac{h^2}{2!} y_0^2 + \frac{h^3}{3!} y_0^3 + \frac{h^4}{4!} y_0^4 + \dots \text{----- (2)}$$

From the Taylor's series, we have  $h = x - x_0 = 1.1 - 1 = 0.1$

Substituting all these values in Equation (2) we get

$$y_1 = f(1.1) = 0 + \frac{0.1}{1!} (1) + \frac{0.1^2}{2!} 2 + \frac{0.1^3}{3!} (2) + \dots$$

$$y_1 = 0.1103$$

$$\therefore y_1 = y(1.1) = 0.1103$$

$$y_2 = f(x_2) = y_1 + \frac{h}{1!} y_1^1 + \frac{h^2}{2!} y_1^2 + \frac{h^3}{3!} y_1^3 + \frac{h^4}{4!} y_1^4 + \dots$$

$$y_1^{11} = x_1 + y_1 \quad y^1(1.1) = 1.1 + 0.1103 = 1.2103$$

Differentiate with respect to x we get

$$y_1^{11} = 1 + y_1^1 \quad y^{11}(1.1) = 1 + 1.2103 = 2.2103$$

$$Y^{111} = Y^{11} \quad y^{111}(0) = 2.2103$$

$$y_2 = f(1.2) = 0.1103 + \frac{0.1}{1!} 1.2103 + \frac{0.1^2}{2!} 2.2103 + \frac{0.1^3}{3!} 2.2103 + \dots = 0.2427$$

### **Example-2:**

Using the Taylor's series method, find an approximate solution correct to four decimals at  $x=0.1$  for the IVP  $\frac{dy}{dx} = x - y^2, y(0) = 1$

Solution:

$$y_1 = x - y^2 \quad y_1(0) = 0 - 1^2 = -1$$

Differentiating w.r.t 'x' we get

$$y_2 = 1 - 2yy_1 \quad y_2(0) = 1 - 2(1)(-1) = 3$$

$$y_3 = -(2yy_2 + 2y_1^2) \quad y_3(0) = -(2(1)(3) + 2(-1)^2) = -8$$

$$y_4 = -2(yy_3 + 3y_1y_2) \quad y_4(0) = -2(1(-8) + 3(-1)(3)) = 34$$

$$f(x) = y_0 + \frac{(x - x_0)}{1!} y_0^1 + \frac{(x - x_0)^2}{2!} y_0^2 + \frac{(x - x_0)^3}{3!} y_0^3 + \dots$$

Where  $x=0.1$  and  $x_0 = 0$  we get

$$y_1 = f(0.1) = 1 + \frac{0.1}{1!}(-1) + \frac{0.1^2}{2!}(-3) + \frac{0.1^3}{3!}(-8) + \frac{0.1^4}{4!}(34) \dots$$

$$y(0.1)=0.91379$$

**Example-3:**

Using the Taylor's series method , find an approximate solution correct to four decimals at  $x=0.1$  for the IVP  $\frac{dy}{dx} = x^2y - 1, y(0) = 1$

Solution:

$$y_1 = x^2y - 1 \qquad y_1(0) = 0 - 1 = -1$$

Differentiating w.r.to.x we get

$$y_2 = 2xy + x^2y_1 \qquad y_2(0) = 2 * 0 * 1 + 0 = 0$$

$$y_3 = 2xy_1 + 2y + 2xy_1 + x^2y_2$$

add the same term we get

$$y_3 = 4xy_1 + 2y + x^2y_2 \qquad y_3(0) = 4 * 0 * -1 + 2 * 1 + 0 = 2$$

$$y_4 = 4xy_2 + 4y_1 + 2y_1 + x^2y_3 + 2xy_2$$

$$y_4 = 6xy_2 + 6y_1 + x^2y_3 \qquad y_4(0) = 0 + 6(-1) + 0 = -6$$

$$f(x) = y_0 + \frac{(x - x_0)}{1!} y_0^1 + \frac{(x - x_0)^2}{2!} y_0^2 + \frac{(x - x_0)^3}{3!} y_0^3 + \dots$$

Where  $x=0.1$  and  $x_0 = 0$  we get

$$y_1 = f(0.1) = 1 + \frac{0.1}{1!}(-1) + \frac{0.1^2}{2!}(0) + \frac{0.1^3}{3!}(2) + \frac{0.1^4}{4!}(-6) + \dots$$

$$y(0.1)=0.9003$$

**Example-4:**

Using the Taylor's series method , find an approximate solution correct to four decimals at  $x=0.1$  for the IVP  $\frac{dy}{dx} = 2y + 3e^x, y(0) = 0$

Solution:

$$y_1 = 2y + 3e^x \qquad y_1(0) = 0 + 3e^0 = 3$$

Differentiating w.r.t x we get

$$y_2 = 2y_1 + 3e^x \qquad y_2(0) = 2 * 3 + 3e^0 = 9$$

$$y_3 = 2y_2 + 3e^x$$

$$y_3(0) = 2 * 9 + 3e^0 = 21$$

$$y_4 = 2y_3 + 3e^x$$

$$y_4(0) = 2 * 21 + 3e^0 = 45$$

$$f(x) = y_0 + \frac{(x-x_0)}{1!}y_0^1 + \frac{(x-x_0)^2}{2!}y_0^2 + \frac{(x-x_0)^3}{3!}y_0^3 + \dots$$

Where  $x=0.1$  and  $x_0 = 0$  we get

$$y_1 = f(0.1) = 0 + \frac{0.1}{1!}(3) + \frac{0.1^2}{2!}(9) + \frac{0.1^3}{3!}(21) + \frac{0.1^4}{4!}(45) + \dots$$

$$y(0.1)=0.3487$$

### **Example-5:**

Using the Taylor's series method, solve  $\frac{dy}{dx} = x^2 + y$  in the range  $0 \leq x \leq 0.2$  by taking step size  $h=0.1$  given that  $y=10$  at  $x=0$  initially considering terms upto the fourth degree.

Sol: in this problem, since step size is specified as 0.1, the problem has to be done in two stage.

Stage 1: By data  $y_1 = x^2 + y$ ,  $y(0) = 10$

$$y_1 = x^2 + y$$

$$y_1(0) = 0 + 10 = 10$$

Differentiating w.r.to.x we get

$$y_2 = 2x + y_1$$

$$y_2(0) = 2(0) + 10 = 10$$

$$y_3 = 2 + y_2$$

$$y_3(0) = 2 + 10 = 12$$

$$y_4 = y_3$$

$$y_4(0) = 12$$

$$\text{We have } f(x) = y_0 + \frac{(x-x_0)}{1!}y_0^1 + \frac{(x-x_0)^2}{2!}y_0^2 + \frac{(x-x_0)^3}{3!}y_0^3 + \dots$$

Where  $x=0.1$  and  $x_0 = 0$  we get

$$y_1 = f(0.1) = 10 + \frac{0.1}{1!}(10) + \frac{0.1^2}{2!}(10) + \frac{0.1^3}{3!}(12) + \frac{0.1^4}{4!}(12) + \dots$$

$$y(0.1)=11.052$$

Stage 2: Now taking  $x_0 = 0.1$   $y_0 = 11.052$

We have

$$y_1 = x^2 + y$$

$$y_1(0.1) = (0.1)^2 + 11.052 = 11.062$$

$$y_2 = 2x + y_1$$

$$y_2(0.1) = 2(0.1) + 11.062 = 11.262$$

$$y_3 = 2 + y_2 \qquad y_3(0.1) = 2 + 11.262 = 13.262$$

$$y_4 = y_3 \qquad y_4(0.1) = 13.262$$

Where  $x=0.2$  and  $x_0 = 0.1$  we get

$$y_1 = f(0.2) = 11.052 + \frac{0.1}{1!} (11.062) + \frac{0.1^2}{2!} (11.262) + \frac{0.1^3}{3!} (13.262) + \frac{0.1^4}{4!} (13.262) + \dots$$

$$y(0.1)=12.2168$$

### **Modified Euler's Method**

Consider the IVP  $\frac{dy}{dx} = f(x, y), y(0) = y_0$  -----(1)

To determine the solution of this problem at  $x_n = x_0 + nh$  bu using Euler's method.

$$y_n^{(E)} = y_{n-1} + hf(x_{n-1}, y_{n-1})$$
-----(2)

The expression 2 gives an approximate value of  $y$  at  $x_n$ . . To improve the approximation the following formula has been suggested

$$y_n = y_{n-1} + \frac{h}{2} [f(x_{n-1}, y_{n-1}) + f(x_n, y_n^{(E)})]$$
-----(3)

The method of computing  $y_n$  using (3) is known as Modified Euler's method.

The process of improving the approximation can be continued by obtaining replacing  $y_n^{(1)}, y_n^{(2)}, y_n^{(3)}$  until the desired degree of accuracy is obtained.

First approximation  $y_1^{(E)} = y_0 + hf(x_0, y_0)$

Second approximation  $y_1^{(1)} = y_0 + \frac{h}{2} [f(x_0, y_0) + f(x_1, y_1^{(E)})]$

Third approximation  $y_1^{(2)} = y_0 + \frac{h}{2} [f(x_0, y_0) + f(x_1, y_1^{(1)})]$  and so on

### **Example :1**

Using the modified Euler's method, solve the IVP  $\frac{dy}{dx} = \frac{1}{x+y}, y(0) = 1$  at points  $x=0.5$  and  $x=1$  in steps of length  $h=0.5$ . Carry out two modifications at each step.

### **Solution:**

$$\frac{dy}{dx} = f(x, y) = \frac{1}{x+y} \quad x_0 = 0, y_0 = 1 \text{ taking } h = 0.5$$

$$y_1^{(E)} = y_0 + hf(x_0, y_0) = y_0 + h \frac{1}{x_0+y_0} = 1 + \frac{0.5}{0+1} = 1.5$$

$$\begin{aligned} \text{First modification } y_1^{(1)} &= y_0 + \frac{h}{2} [f(x_0, y_0) + f(x_1, y_1^{(E)})] \\ &= y_0 + \frac{h}{2} \left[ \frac{1}{x_0 + y_0} + \frac{1}{x_0 + y_1^E} \right] = 1 + \frac{0.5}{2} \left[ \frac{1}{0 + 1} + \frac{1}{0.5 + 1.5} \right] = 1.375 \end{aligned}$$

$$\begin{aligned} \text{Second modification } y_1^{(2)} &= y_0 + \frac{h}{2} [f(x_0, y_0) + f(x_1, y_1^{(1)})] \\ &= y_0 + \frac{h}{2} \left[ \frac{1}{x_0 + y_0} + \frac{1}{x_0 + y_1^1} \right] = 1 + \frac{0.5}{2} \left[ \frac{1}{0 + 1} + \frac{1}{0.5 + 1.375} \right] = 1.3833 \end{aligned}$$

Next, to compute the solution  $y_2 = y(1)$  and let us consider  $x_0 = 0.5, y_0 = 1.3833$

$$y_1^{(E)} = y_0 + hf(x_0, y_0) = y_0 + h \frac{1}{x_0 + y_0} = 1.3833 + \frac{0.5}{0.5 + 1.3833} = 1.6488$$

$$\begin{aligned} \text{First modification } y_1^{(1)} &= y_0 + \frac{h}{2} [f(x_0, y_0) + f(x_1, y_1^{(E)})] \\ &= y_0 + \frac{h}{2} \left[ \frac{1}{x_0 + y_0} + \frac{1}{x_0 + y_1^E} \right] = 1.3833 + \frac{0.5}{2} \left[ \frac{1}{0.5 + 1.3833} + \frac{1}{1 + 1.6488} \right] = \\ &= 1.6104 \end{aligned}$$

$$\begin{aligned} \text{second modification } y_1^{(2)} &= y_0 + \frac{h}{2} [f(x_0, y_0) + f(x_1, y_1^{(1)})] \\ &= y_0 + \frac{h}{2} \left[ \frac{1}{x_0 + y_0} + \frac{1}{x_0 + y_1^1} \right] = 1.3833 + \frac{0.5}{2} \left[ \frac{1}{0.5 + 1.3833} + \frac{1}{1 + 1.6104} \right] \\ &= 1.6118 \end{aligned}$$

The required solution are  $y(0.5)=1.3833$  and  $y(1)=1.6118$

### Example: 2

Using the modified Euler's method, solve the IVP  $\frac{dy}{dx} = x + y^2, y(0) = 1$  at points  $x=0.1$  in steps of length  $h=0.1$ . Carry out two modifications.

**Solution:**

$$\frac{dy}{dx} = f(x, y) = x + y^2 \quad x_0 = 0, y_0 = 1 \text{ taking } h = 0.1$$

$$y_1^{(E)} = y_0 + hf(x_0, y_0) = y_0 + h(x_0 + y_0^2) = 1 + 0.1 * (0 + 1) = 1.1$$

$$\begin{aligned} \text{First modification } y_1^{(1)} &= y_0 + \frac{h}{2} [f(x_0, y_0) + f(x_1, y_1^{(E)})] \\ &= y_0 + \frac{h}{2} [x_0 + y_0^2 + x_0 + ((y_1^E)^2)] = 1 + \frac{0.1}{2} [0 + 1 + (0.1 + 1.1^2)] = 1.1155 \end{aligned}$$

$$\text{second modification } y_1^{(2)} = y_0 + \frac{h}{2} [f(x_0, y_0) + f(x_1, y_1^{(1)})]$$

$$= y_0 + \frac{h}{2} [x_0 + y_0^2 + x_0 + ((y_1^1)^2)] = 1 + \frac{0.1}{2} [0 + 1 + (0.1 + 1.1155^2)] = 1.1172$$

Hence the required solution is  $y(0.1)=1.1172$

### Example :3

Using the modified Euler's method, solve the IVP  $\frac{dy}{dx} = 1 + \frac{y}{x}$ ,  $y(1) = 2$  at points  $x=0.1$  in steps of length  $h=0.2$ . Carry out three modifications.

#### Solution:

$$\frac{dy}{dx} = f(x, y) = 1 + \frac{y}{x} \quad x_0 = 1, y_0 = 2 \text{ taking } h = 0.2$$

$$y_1^{(E)} = y_0 + hf(x_0, y_0) = y_0 + h \left[ 1 + \frac{y_0}{x_0} \right] = 2 + 0.2 \left( 1 + \frac{2}{1} \right) = 2.6$$

$$\text{First modification } y_1^{(1)} = y_0 + \frac{h}{2} [f(x_0, y_0) + f(x_1, y_1^{(E)})]$$

$$= y_0 + \frac{h}{2} \left[ 1 + \frac{y_0}{x_0} + 1 + \frac{y_1^{(E)}}{x_0} \right] = 2 + \frac{0.2}{2} \left[ 1 + \frac{2}{1} + \left( 1 + \frac{2.6}{1.2} \right) \right] = 2.6167$$

$$\text{second modification } y_1^{(2)} = y_0 + \frac{h}{2} [f(x_0, y_0) + f(x_1, y_1^{(1)})]$$

$$= y_0 + \frac{h}{2} \left[ 1 + \frac{y_0}{x_0} + 1 + \frac{y_1^{(1)}}{x_0} \right] = 2 + \frac{0.2}{2} \left[ 1 + \frac{2}{1} + \left( 1 + \frac{2.6167}{1.2} \right) \right] = 2.6181$$

$$\text{Third modification } y_1^{(3)} = y_0 + \frac{h}{2} [f(x_0, y_0) + f(x_1, y_1^{(2)})]$$

$$= y_0 + \frac{h}{2} \left[ 1 + \frac{y_0}{x_0} + 1 + \frac{y_1^{(2)}}{x_0} \right] = 2 + \frac{0.2}{2} \left[ 1 + \frac{2}{1} + \left( 1 + \frac{2.6181}{1.2} \right) \right] = 2.61812$$

Hence, the value of  $y$  at  $x=1.2$  is 2.6182

### Example:4

Using Modified Euler's method, find  $y(0.1)$  given  $\frac{dy}{dx} = x^2 + y$  &  $y = 1$  when  $x = 0$  by taking  $h = 0.05$ . Perform two iterations in each step.

#### Solution:

$$f(x, y) = x^2 + y, \quad x_0 = 0, y_0 = 1 \text{ \& } h = 0.05, \text{ Hence } f(x_0, y_0) = 0 + 1 = 1$$

$$\therefore y_1^{(0)} = y_0 + hf(x_0, y_0) = 1 + 0.05 \times 1 = 1.05. \text{ Now } f(x_1, y_1^{(0)}) = 0.05^2 + 1.05 = 1.0525$$

$$\therefore y_1^{(1)} = y_0 + \frac{h}{2} [f(x_0, y_0) + f(x_1, y_1^{(0)})] = 1 + \frac{0.05}{2} [1 + 1.0525] = 1.0513.$$

$$\text{Now } f(x_1, y_1^{(1)}) = 0.05^2 + 1.0513 = 1.0538$$

$$\therefore y_1^{(2)} = y_0 + \frac{h}{2} [f(x_0, y_0) + f(x_1, y_1^{(1)})] = 1 + \frac{0.05}{2} [1 + 1.0538] = 1.0513. \text{ Hence}$$

$$y_1 = y(0.05) = 1.0513$$

$$\text{Now } f(x_1, y_1) = 0.05^2 + 1.0513 = 1.0538$$

$$\therefore y_2^{(0)} = y_1 + hf(x_1, y_1) = 1.0513 + 0.05 \times 1.0538 = 1.1040. \text{ Now}$$

$$f(x_2, y_2^{(0)}) = 0.1^2 + 1.1040 = 1.114$$

$$\therefore y_2^{(1)} = y_1 + \frac{h}{2} [f(x_1, y_1) + f(x_2, y_2^{(0)})] = 1.0513 + \frac{0.05}{2} [1.0538 + 1.114] = 1.1055.$$

$$\text{Now } f(x_2, y_2^{(1)}) = 0.1^2 + 1.1055 = 1.1155$$

$$\therefore y_2^{(2)} = y_1 + \frac{h}{2} [f(x_1, y_1) + f(x_2, y_2^{(1)})] = 1.0513 + \frac{0.05}{2} [1.0538 + 1.1155] = 1.1055.$$

$$\text{Hence } y_2 = y(0.1) = 1.1055.$$

### **RUNGE-KUTTA METHOD (R-K METHOD)**

Consider the IVP  $\frac{dy}{dx} = f(x, y), y(0) = y_0$  -----(1)

To determine the solution of this problem at  $x_n = x_0 + nh$  by using this method, where  $h$  is step length

According to the Euler's method, the solution at  $x_1$  is  $y_0 + hf(x_0, y_0)$ .

This can be rewritten as  $y_1 = y_0 + K$

where

$$k_1 = hf(x_0, y_0)$$

$$k_2 = hf\left(x_0 + \frac{h}{2}, y_0 + \frac{k_1}{2}\right)$$

$$k_3 = hf\left(x_0 + \frac{h}{2}, y_0 + \frac{k_2}{2}\right)$$

$$k_4 = hf(x_0 + h, y_0 + k_3)$$

$y_1 = y_0 + \frac{k_1 + 2k_2 + 2k_3 + k_4}{6}$  is an approximate solution for the equation (1) at  $x_1$ , known as Runge-Kutta method of order four.

**Example:1**

Using RK method of fourth order , to find  $y(0.2)$ , given that  $\frac{dy}{dx} = \frac{y-x}{y+x}$  and  $y(0) = 1$  take  $h = 0.2$

Solution

$$\frac{dy}{dx} = f(x, y) = \frac{y-x}{y+x}, x_0 = 0, y_0 = 1 \text{ and } h = 0.2 \text{ then } x_1 = x_0 + h = 0.2$$

$$k_1 = hf(x_0, y_0) = h \left( \frac{y_0 - x_0}{y_0 + x_0} \right) = (0.2) \left( \frac{1-0}{1+0} \right) = 0.2$$

$$k_2 = hf \left( x_0 + \frac{h}{2}, y_0 + \frac{k_1}{2} \right) = h \left( \frac{y_0 + \frac{k_1}{2} - (x_0 + \frac{h}{2})}{y_0 + \frac{k_1}{2} + (x_0 + \frac{h}{2})} \right)$$

$$= 0.2 \left( \frac{1.1-0.1}{1.1+0.1} \right) = 0.16667$$

$$k_3 = hf \left( x_0 + \frac{h}{2}, y_0 + \frac{k_2}{2} \right) = h \left( \frac{y_0 + \frac{k_2}{2} - (x_0 + \frac{h}{2})}{y_0 + \frac{k_2}{2} + (x_0 + \frac{h}{2})} \right)$$

$$= 0.2 \left( \frac{1+0.083335-0.1}{1.1+0.11+0.083335+0.1} \right) = \frac{0.196667}{1.183335} = 0.166197$$

$$k_4 = hf(x_0 + h, y_0 + k_3) = h \left( \frac{y_0 + k_3 - (x_0 + h)}{y_0 + k_3 + (x_0 + h)} \right)$$

$$= 0.2 \left( \frac{1.166197 - 0.2}{1.166197 + 0.2} \right) = \frac{0.1932394}{1.366197} = 0.14144$$

$$y_1 = y_0 + \frac{k_1 + 2k_2 + 2k_3 + k_4}{6}$$

$$= 1 + \frac{0.2 + 2(0.16667) + 2(0.166197) + 0.14144}{6}$$

$$y_1 = 1.16786$$

**Example :2**

Using RK method of fourth order , to find  $y(0.2)$ , given that  $\frac{dy}{dx} = x^2 - y$  and  $y(0) = 1$  take  $h = 0.1$

Solution

$$\frac{dy}{dx} = f(x, y) = x^2 - y, x_0 = 0, y_0 = 1 \text{ and } h = 0.1 \text{ then } x_1 = x_0 + h = 0.1$$

$$k_1 = hf(x_0, y_0) = h(x_0^2 - y_0) = 0.1 * (0 - 1) = -0.1$$

$$\begin{aligned}
k_2 &= hf\left(x_0 + \frac{h}{2}, y_0 + \frac{k_1}{2}\right) = h\left(\left(x_0 + \frac{h}{2}\right)^2 - \left(y_0 + \frac{k_1}{2}\right)\right) \\
&= 0.1\left(0 + \frac{0.1}{2}\right)^2 - \left(1 + \frac{-0.1}{2}\right) = 0.1((0.05)^2 - 0.95) = -0.09475 \\
k_3 &= hf\left(x_0 + \frac{h}{2}, y_0 + \frac{k_2}{2}\right) = h\left(\left(x_0 + \frac{h}{2}\right)^2 - \left(y_0 + \frac{k_2}{2}\right)\right) \\
&= 0.1((0.05)^2 - (1 - 0.047375)) = -0.0950125 \\
k_4 &= hf(x_0 + h, y_0 + k_3) = h((x_0 + h)^2 - (y_0 + k_3)) \\
&= 0.1((0.05)^2 - (1 - 0.0950125)) = -0.0895 \\
y_1 &= y_0 + \frac{k_1 + 2k_2 + 2k_3 + k_4}{6} \\
&= 1 + \frac{-0.1 - 0.1895 - 0.190025 - 0.0895}{6} \\
&= 0.90516
\end{aligned}$$

**Example 3:** Use fourth Runge –Kutta method to find at  $x = 0.1$  given that

$$\frac{dy}{dx} = 3e^x + 2y, y(0) \text{ and } h=0.1$$

>> By data,  $f(x,y)=3e^x + 2y, x_0 = 0, y_0 = 0, h=0.1$

We shall compute  $k_1, k_2, k_3, k_4$

$$k_1 = hf(x_0, y_0) = (0.1)f(0,0) = (0.1)[3e^0 + 2 \times 0] = 0.3$$

$$k_2 = hf\left(x_0 + h\frac{h}{2}, y_0 + \frac{k_1}{2}\right) = (0.1)f(0.05, 0.15)$$

$$= (0.1) [3e^{0.05} + 2(0.15)] = 0.3454$$

$$k_3 = hf\left(x_0 + \frac{h}{2}, y_0 + \frac{k_2}{2}\right) = (0.1)f(0.05, 0.1727)$$

$$= (0.1)[3e^{0.05} + 2(0.1727)] = 0.3499$$

$$k_4 = hf(x_0 + h, y_0 + k_3) = (0.1)f(0.1, 0.3499)$$

$$= (0.1)[3e^{0.1} + 2(0.3499)] = 0.4015$$

$$y_1 = y_0 + \frac{k_1 + 2k_2 + 2k_3 + k_4}{6}$$

$$= 1 + \frac{0.3 + 2(0.3454) + 2(0.3499) + 0.4015}{6}$$

$$= 0.3487$$

**Example 4:**

Use fourth order Runge-kutta method to compute  $y(1.1)$  given that

$$\frac{dy}{dx} = xy^{\frac{1}{3}}, \quad y(1) = 1$$

**Solution**

>>By data  $f(x, y) = xy^{\frac{1}{3}}$   $x_0 = 1$ ,  $y_0 = 1$  and we need to compute  $y(1.1)$  implies  $x_0 + h = 1.1 \therefore h = 0.1$

We shall compute  $k_1, k_2, k_3, k_4$

$$k_1 = hf(x_0, y_0) = (0.1)f(1, 1) = (0.1)\left[(1)(1)^{\frac{1}{3}}\right] = 0.1$$

$$k_2 = hf\left(x_0 + \frac{h}{2}, y_0 + \frac{k_1}{2}\right) = (0.1)f(1.05, 1.05)$$

$$= (0.1)[(1.05)(1.05)^{\frac{1}{3}}] = 0.1067$$

$$k_3 = hf\left(x_0 + \frac{h}{2}, y_0 + \frac{k_2}{2}\right) = (0.1)f(1.05, 1.05335)$$

$$= (0.1)[(1.05)(1.05335)^{\frac{1}{3}}] = 0.1068$$

$$k_4 = hf(x_0 + h, y_0 + k_3) = (0.1)f(1.1, 1.1068)$$

$$= (0.1)[(1.1)(1.1068)^{\frac{1}{3}}] = 0.1138$$

$$y(x_0 + h) = y_0 + \frac{1}{6} [0.1 + 2(0.1067) + 2(0.1068) + 0.1138]$$

$$y(1.1) = 1.1068$$

**Example 5:**

Using Runge Kutta method of fourth order solve  $\frac{dy}{dx} + y = 2x$  at  $x = 1.1$

Given that  $y=3$  at  $x = 1$  initially.

**Solution:**

>> We have  $\frac{dy}{dx} = 2x - y, x_0 = 1, y_0 = 3$

$$f(x, y) = 2x - y, x_0 + h = 1.1 \therefore h = 0.1$$

$$\frac{dy}{dx} = f(x, y) = 2x - y, x_0 = 1, y_0 = 3 \text{ and } h = 0.1 \text{ then } x_1 = x_0 + h = 0.1$$

$$k_1 = hf(x_0, y_0) = h(2x_0 - y_0) = 0.1 * (2 - 3) = -0.1$$

$$k_2 = hf\left(x_0 + \frac{h}{2}, y_0 + \frac{k_1}{2}\right) = 0.1hf(1.05, 2.95) = \\ = 0.1(2 * 1.05 - 2.95) = -0.085$$

$$k_3 = hf\left(x_0 + \frac{h}{2}, y_0 + \frac{k_2}{2}\right) = hf(1.05, 2.91425) \\ = 0.1(2 * 1.05 - 2.91425) = -0.08575$$

$$k_4 = hf(x_0 + h, y_0 + k_3) = hf(1.1, 2.91425) \\ = 0.1(2 * 1.1 - 2.91425) = -0.071425$$

$$y_1 = y_0 + \frac{k_1 + 2k_2 + 2k_3 + k_4}{6} \\ = 1 + \frac{-0.1 - 0.085 - 0.08575 - 0.071425}{6} \\ = 2.9145$$

**Example 6:**

Using Runge Kutta method of fourth order solve  $(y^2 - x^2)dx = (y^2 + x^2)dy$  for  $x = 0.2$  and  $0.4$  given that  $y = 1$  at  $x = 0$  initially, by applying Runge - Kutta method of order 4.

**Solution:**

We have  $f(x, y) = \frac{(y^2 - x^2)}{(y^2 + x^2)}, x_0 = 0, y_0 = 1$  and  $h = 0.2$

Stage -1:

$$f(x, y) = \frac{(y^2 - x^2)}{(y^2 + x^2)}$$

$$\frac{dy}{dx} = f(x, y) = \frac{(y^2 - x^2)}{(y^2 + x^2)}, x_0 = 0, y_0 = 1 \text{ and } h = 0.2 \text{ then } x_1 = x_0 + h = 0.2$$

$$k_1 = hf(x_0, y_0) = (0.2)f(0, 1) = 0.2$$

$$k_2 = hf\left(x_0 + \frac{h}{2}, y_0 + \frac{k_1}{2}\right) = (0.2)f(0.1, 1.1) = 0.1967$$

$$k_3 = hf\left(x_0 + \frac{h}{2}, y_0 + \frac{k_2}{2}\right) = (0.2)f(0.1, 1.0984) = 0.1967$$

$$k_4 = hf(x_0 + h, y_0 + k_3) = (0.2)f(0.2, 1.1967) = 0.1891$$

$$y(x_0 + h) = y_0 + \frac{k_1 + 2k_2 + 2k_3 + k_4}{6}$$

$$y(0.2) = 1 + \frac{0.2 + 2(0.1967) + 2(0.1967) + 0.1891}{6} = 1.196$$

### **Stage-2:**

$$\frac{dy}{dx} = f(x, y) = \frac{(y^2 - x^2)}{(y^2 + x^2)}, x_0 = 0.2, y_0 = 1.196 \text{ and } h = 0.2 \text{ then } x_1 = x_0 + h = 0.4$$

$$k_1 = hf(x_0, y_0) = (0.2)f(0.2, 1.196) = 0.1891$$

$$k_2 = hf\left(x_0 + \frac{h}{2}, y_0 + \frac{k_1}{2}\right) = (0.2)f(0.3, 1.29055) = 0.1795$$

$$k_3 = hf\left(x_0 + \frac{h}{2}, y_0 + \frac{k_2}{2}\right) = (0.2)f(0.3, 1.28575) = 0.1793$$

$$k_4 = hf(x_0 + h, y_0 + k_3) = (0.2)f(0.4, 1.3753) = 0.1688$$

$$y(x_0 + h) = y_0 + \frac{k_1 + 2k_2 + 2k_3 + k_4}{6}$$

$$y(0.4) = 1.196 + \frac{0.1891 + 2(0.1795) + 2(0.1793) + 0.1688}{6} = 1.3753$$

### **Milne's Method:**

The method in which the construction of  $y_n$  involves the use of not only  $y_{n-1}$  but also predecessors are called multi step methods. In multi-step methods two formulas are used in conjunction with each other- one for predicting the value of  $y_n$  and the other for correcting the predicted value of  $y_n$ .

Consider the IVP  $\frac{dy}{dx} = f(x, y) \dots (1)$

Let  $y_0=y(x_0), y_1=y(x_1), y_2=y(x_2)$  and  $y_3=y(x_3)$  be these known solutions.

Suppose we wish to determine the solution of equation (1) at the point  $x_4 = x_3+h$ .

Let us denote the required solution by  $y_4=y(x_4)$ .

First we predict the value of  $y_4=y(x_4)$  by using Milne's predictor formula:

$$y_4^{(p)} = y_0 + \frac{4h}{3}(2f_1 - f_2 + 2f_3) \quad \text{--- (2)}$$

which can be computed with the help of the specified  $x_0, x_1, x_2, x_3$  and  $y_0, y_1, y_2, y_3$

Next we correct the value of  $y_4$  by using the Milne's corrector formula:

$$y_4^{(c)} = y_2 + \frac{h}{3}(f_2 + 4f_3 + f_4^{(p)}) \quad \text{--- (3)}$$

where  $f_4^{(p)} = f(x_4, y_4^{(p)})$

If we wish to have more accurate approximation for  $y$ , we employ the process repeatedly

### Example :1

Use Milne's predictor –corrector method to find the value of  $y$  at  $x=0.8$ , given

$\frac{dy}{dx} = x - y^2$  Where  $y(0)=0$ ,  $y(0.2)=0.02$ ,  $y(0.4)=0.0795$ ,  $y(0.6)=0.1762$ . Apply corrector formula twice.

**Solution:**

Here  $f(x, y) = x - y^2, h = 0.2$

X	Y	$f(x, y) = x - y^2$
$x_0=0$	$y_0=0$	$f_0=0-0^2=0$
$X_1=0.2$	$y_1=0.02$	$f_1=0.2-0.02^2=0.1996$
$X_2=0.4$	$y_2=0.0795$	$f_2=0.4-0.0795^2=0.3937$
$X_3=0.6$	$y_3=0.1762$	$f_3=0.6-0.1762^2=0.5689$

Now, Milne's Predictor formula yields the predicted value of  $y_4$  as

$$y_4^{(p)} = y_0 + \frac{4h}{3}(2f_1 - f_2 + 2f_3) = 0 + \frac{4 * 0.2}{3}(2(0.1996) - 0.3937 + 2(0.5689)) = 0.3048$$

$$f_4^{(p)} = f(x_4, y_4^{(p)}) = x_4 - y_4^{(p)2} = 0.8 - (0.30488)^2 = 0.7070$$

Now, the Milne's corrector formula gives a corrected value of  $y_4$  as

$$y_4^{(c)} = y_2 + \frac{h}{3}(f_2 + 4f_3 + f_4^{(p)}) = 0.0795 + \frac{0.2}{3}(0.3937 + 4(0.5689) + 0.7070) = 0.3046$$

To apply corrector formula second time we must use corrector as predictor and substitute in  $f_4^{(p)}$

$$f_4^{(p)} = f(x_4, y_4^{(p)}) = x_4 - y_4^{(p)2} = 0.8 - (0.3046)^2 = 0.7072$$

$$y_4^{(c)} = y_2 + \frac{h}{3}(f_2 + 4f_3 + f_4^{(p)}) = 0.0795 + \frac{0.2}{3}(0.3937 + 4(0.5689) + 0.7072) = 0.3046$$

This twice corrected value of  $y_4$  is the required value of  $y$  at  $x=0.8$ .

### Example :2

Use Milne's predictor –corrector method Given the differential equation , given  $5x \frac{dy}{dx} + y^2 - 2 = 0$  and the set of values of  $(x,y)$  given in the following table, find the value of  $y$  at  $x=4.5$  using the Milne's method

Where  $y(4)=1$  ,  $y(4.1)=1.0049$  ,  $y(4.2)=1.0097$  ,  $y(4.3)=1.0143$  ,  $y(4.4)=1.0187$  . Apply corrector formula twice.

### Solution:

$$\text{Here } f(x, y) = - \left[ \frac{y^2 - 2}{5x} \right] = \left[ \frac{2 - y^2}{5x} \right]$$

X	Y	$f(x, y) = \left[ \frac{2 - y^2}{5x} \right]$
$x_0=4$	$y_0=1$	$f_0 = \left[ \frac{2 - 1.0097^2}{5(4.2)} \right] = 0.04669$
$X_1=4.1$	$y_1=1.0049$	$f_1 = \left[ \frac{2 - 1.0097^2}{5(4.2)} \right] = 0.04669$
$X_2=4.2$	$y_2=1.0097$	$\left[ \frac{2 - 1.0097^2}{5(4.2)} \right] = 0.04669$
$X_3=4.3$	$y_3=1.0143$	$\left[ \frac{2 - 1.0097^2}{5(4.2)} \right] = 0.04517$
$X_4=4.4$	$Y_4=1.0187$	$\left[ \frac{2 - 1.0097^2}{5(4.2)} \right] = 0.04374$

Now , Milne's Predictor formula yields the predicted value of  $y_4$  as

$$y_4^{(p)} = y_0 + \frac{4h}{3}(2f_1 - f_2 + 2f_3) = 1.0049 + \frac{4 * 0.1}{3}(2(0.04669) - 0.04517 + 2(0.04374)) = 1.02299$$

$$f(x_4, y_4^{(p)}) = \left[ \frac{2 - y_4^{(p)2}}{5x} \right] = \left[ \frac{2 - 1.02299^2}{5(4.5)} \right] = 0.042378$$

Now, the Milne's corrector formula gives a corrected value of  $y_4$  as

$$y_4^{(c)} = y_2 + \frac{h}{3} (f_2 + 4f_3 + f_4^{(p)}) = 1.0143 + \frac{0.1}{3} (0.04517 + 4(0.04374) + 0.042378) = 1.02305$$

To apply corrector formula second time we must use corrector as predictor and substitute in  $f_4^{(p)}$

$$f_4^{(p)} = f(x_4, y_4^{(p)}) = \left[ \frac{2 - 1.02305^2}{5(4.5)} \right] = 0.042372$$

$$y_4^{(c)} = y_2 + \frac{h}{3} (f_2 + 4f_3 + f_4^{(p)}) = 1.0143 + \frac{0.1}{3} (0.04517 + 4(0.04374) + 0.042372) = 1.02305$$

This twice corrected value of  $y_4$  is the required value of  $y$  at  $x=4.5$ .

**Example :3**

Use Milne's predictor –corrector method Given the differential equation, given

$\frac{dy}{dx} = x^2(1 + y)$  at 1.4 . Carry out two corrections for the solution, given that  $y(1)=1$ ,  $y(1.1)=1.233$  ,  $y(1.2)=1.548$  ,  $y(1.3)=1.979$ .

Solution:

Here  $f(x, y) = x^2(1 + y)$  ,  $h = 0.1$

X	Y	$f(x, y) = x^2(1 + y)$
$x_0=1$	$y_0=1$	$f_0=1^2(1+1)=2$
$X_1=1.1$	$y_1=1.233$	$f_1 = 2.702$
$X_2=1.2$	$y_2=1.548$	$f_2 = 3.669$
$X_3=1.3$	$y_3=1.979$	$f_3 = 5.035$

$$y_4^{(p)} = y_0 + \frac{4h}{3} (2f_1 - f_2 + 2f_3)$$

$$= 1 + \frac{4(0.1)}{3} (2 * 2.702 - 3.669 + 2 * 5.035) = 2.572 \text{ -----(1)}$$

$$f_4^{(p)} = f(x_4, y_4^{(p)}) = x_4^2(1 + y_4^{(p)}) = 1.4^2(1 + 2.572) = 5.0008$$

$$y_4^{(c)} = y_2 + \frac{h}{3} (f_2 + 4f_3 + f_4^{(p)}) \text{ -----(2)}$$

$$= 1.548 + \frac{0.1}{3} (3.669 + 4 * 5.035 + 5.0008) = 2.5089$$

To get a correction of this solution  $y_4^{(p)} = 2.5089$

$$f_4^{(p)} = f(x_4, y_4^{(p)}) = x_4^2(1 + y_4^{(p)}) = 1.4^2(1 + 2.5089) = 6.8774$$

$$y_4^{(c)} = 1.548 + \frac{0.1}{3} (3.669 + 4 * 5.035 + 6.8774)$$

$y(1.4)=2.5752$  is the required solution as correct to 4 decimal places.

**Example :4**

Use Milne’s predictor –corrector method Given the differential equation  $\frac{dy}{dx} = x^2 + \frac{y}{2}$  find  $y(1.4)$  given that  $y(1)=2$ ,  $y(1.1)=2.2156$ ,  $y(1.2)=2.4649$ ,  $y(1.3)=2.7514$ .

Solution:

Here  $f(x, y) = x^2 + \frac{y}{2}$ ,  $h = 0.1$

X	Y	$f(x, y) = x^2 + \frac{y}{2}$
$x_0=1$	$y_0=2$	$f_0=2$
$X_1=1.1$	$y_1=2.2156$	$f_1 = 2.3178$
$X_2=1.2$	$y_2=2.4649$	$f_2 = 2.6724$
$X_3=1.3$	$y_3=2.7514$	$f_3 = 3.0657$

$$y_4^{(p)} = y_0 + \frac{4h}{3} (2f_1 - f_2 + 2f_3)$$

$$y_4^{(p)} = 1 + \frac{4(0.1)}{3} (2 * 2.3178 - 2.6724 + 2 * 3.0657) = 3.0793 \text{ -----(1)}$$

$$f_4^{(p)} = f(x_4, y_4^{(p)}) = x_4^2 + \frac{y_4^{(p)}}{2} = 1.4^2 + \frac{3.0793}{2} = 3.49965$$

$$y_4^{(c)} = y_2 + \frac{h}{3} (f_2 + 4f_3 + f_4^{(p)}) \text{ -----(2)}$$

$$= 2.4649 + \frac{0.1}{3} (2.6724 + 4 * 3.0657 + 3.49965) = 3.0794$$

To get a correction of this solution  $y_4^{(p)} = 3.0794$

$$f_4^{(p)} = f(x_4, y_4^{(p)}) = x_4^2 + \frac{y_4^{(p)}}{2} = 1.4^2 + \frac{3.0794}{2} = 3.4997$$

$$y_4^{(c)} = 2.4649 + \frac{0.1}{3} (2.6724 + 4 * 3.0657 + 3.4997) = 3.0794$$

**Example :5**

If  $\frac{dy}{dx} = 2e^x - y$ ,  $y(0)=2$ ,  $y(0.1)=2.010$ ,  $y(0.2)=2.040$ ,  $y(0.3)=2.090$ . find  $y(0.4)$  Using Milne’s predictor –corrector method

Here  $f(x, y) = 2e^x - y$ ,  $h = 0.1$

X	Y	$f(x, y) = 2e^x - y$
$x_0=0$	$y_0=2$	$f_0=0$
$X_1=0.1$	$y_1=2.010$	$f_1 = 0.2003$
$X_2=0.2$	$y_2=2.040$	$f_2 = 0.4028$
$X_3=0.3$	$y_3=2.090$	$f_3 = 0.6097$

$$y_4^{(p)} = y_0 + \frac{4h}{3}(2f_1 - f_2 + 2f_3)$$

$$y_4^{(p)} = 1 + \frac{4(0.1)}{3} (2 * 0.2003 - 0.4028 + 2 * 0.6097) = 2.1623 \text{ -----(1)}$$

$$f_4^{(p)} = f(x_4, y_4^{(p)}) = 2e^{x_4} - y_4^{(p)} = 2e^{0.4} - 2.1623 = 0.8213$$

$$y_4^{(c)} = y_2 + \frac{h}{3}(f_2 + 4f_3 + f_4^{(p)}) \text{ -----(2)}$$

$$= 2.040 + \frac{0.1}{3} (0.4028 + 4 * 0.6097 + 0.8213) = 2.1621$$

To get a correction of this solution  $y_4^{(p)} = 2.1621$

$$f_4^{(p)} = f(x_4, y_4^{(p)}) = 2e^{x_4} - y_4^{(p)} = 2e^{0.4} - 2.1621 = 0.8215$$

$$y_4^{(c)} = 2.040 + \frac{0.1}{3} (0.4028 + 4 * 0.6097 + 0.8215) = 2.1621$$

**Exercises**

1) Evaluate  $y(0.1)$  correct to 6 places of decimals by Taylor’s series method if  $y(x)$  satisfies

$$y' = xy + 1, \quad y(0) = 1. \quad [\text{Ans: } y(x) = 1 + x + \frac{x^2}{2} + \frac{x^3}{3} + \frac{x^4}{8} + \frac{x^5}{15} + \frac{x^6}{48} + \dots \quad \& \quad y(0.1) = 1.1053]$$

2) Solve  $y' = y^2 + x$ ,  $y(0) = 1$  using Taylor’s series method & compute  $y(0.1)$  &  $y(0.2)$

$$[\text{Ans: } y(x) = 1 + x + \frac{3}{2}x^2 + \frac{4}{3}x^3 + \frac{17}{12}x^4 + \frac{31}{20}x^5 + \dots \text{ and } y(0.1) = 1.1165, y(0.2) = 1.2734]$$

3) Use Taylor’s series method to find  $y$  at the point  $x = 0.1$  &  $x = 0.2$ , given that

$$\frac{dy}{dx} = x^2 + y^2, \quad y(0) = 1$$

- 4) Given  $\frac{dy}{dx} = \frac{y-x}{y+x}$  with boundary condition  $y = 1$  when  $x = 0$ , find approximately  $y$  for  $x = 0.1$  by Modified Euler's method [Ans: 1.0928]
- 5) Given that  $\frac{dy}{dx} = x + y^2$  &  $y = 1$  at  $x = 0$ . Find a approximate value of  $y$  at  $x = 0.5$  by Modified Euler's method. [Ans: 2.2352]
- 6) Solve the differential equation  $\frac{dy}{dx} = -xy^2$ ,  $y = 2$  at  $x = 0$ , by Modified Euler's method & obtain  $y$  at  $x = 0.2$  in two stages of 0.1 each. [Ans: 1.9227]
- 7) Using Runge – Kutta method of order 4, compute  $y(0.2)$  &  $y(0.4)$  from  $10\frac{dy}{dx} = x^2 + y^2$ ,  $y(0) = 1$ , taking  $h = 0.1$  [Ans: 1.0207, 1.0438]
- 8) Use Runge – Kutta fourth order method to find  $y$  when  $x = 1.2$  in steps of 0.1 given that  $\frac{dy}{dx} = x^2 + y^2$  &  $y(1) = 1.5$  [Ans: 2.5005]
- 9) Using Runge-Kutta method of order 4, compute  $y(0.2)$  for the equation,  $y' = y - \frac{2x}{y}$ ,  $y(0) = 1.0$  (Take  $h = 0.2$ ) [Ans: 1.18323]
- 10) Using Runge – Kutta method of order 4, find  $y(0.2)$  for the equation  $\frac{dy}{dx} = \frac{y-x}{y+x}$ ,  $y(0) = 1$ . Take  $h = 0.2$ . [Ans: 1.1678 ]
- 11) If  $\frac{dy}{dx} = 2e^x - y$ ,  $y(0) = 2$ ,  $y(0.1) = 2.010$ ,  $y(0.2) = 2.04$  and  $y(0.3) = 2.09$  find  $y(0.4)$  correct to four decimal places. By using Milne's predictor-corrector method. (Use corrector formula twice). [Ans: 2.1621 & 2.2546]
- 12) Given  $2\frac{dy}{dx} = (1 + x^2)y^2$  &  $y(0) = 1$ ,  $y(0.1) = 1.06$ ,  $y(0.2) = 1.12$ ,  $y(0.3) = 1.21$ . Evaluate  $y(0.4)$  by Milne's predictor – corrector method.[Ans: 1.2797]